



DAIDO STEEL GROUP
Beyond the Special

INTEGRATED
REPORT
2023

Foreword

We will further enhance sustainability management under the new system, carrying on the founding principles of our organization.

Our history can be traced back to 1916, when Momosuke Fukuzawa, our founder, decided to use the electricity produced by hydroelectric power generation to build an electric arc furnace steelmaking company. When founder Momosuke Fukuzawa became president of Nagoya Dento Co., Ltd., he established the “GOKAI-JUSSOKU (Ten Guiding Tenets)” for his employees, the first of which was the following words:

“The happiness we enjoy is thanks to the patronage of many customers”

Since our company’s establishment more than 100 years ago, we have carried on the tradition of appreciating our customers as the DNA of Daido Steel, while also refining our “monozukuri” (manufacturing) skills and giving back to society.

Specialty steel has excellent functionality and design, and it can be used creatively to produce a wide range of materials. Our products are used in many industries. Our mission and purpose is to listen carefully to the voices of our customers (= society) and continue to provide products that support people’s lives, an attitude that we have cherished since our founding.

In light of this, on the occasion of our 100th anniversary, we updated our management philosophy to “Pursuing the potential of materials to support our future,” while also creating the Group’s slogan, “Beyond the Special.” We want you to feel the Daido Steel Group’s enthusiasm for maximizing material potential and continuing on with “value that goes beyond special.”

The world is currently faced with numerous problems, including those related to energy and global warming. Without each company utilizing its knowledge and experience to promote sustainability initiatives and help achieve the SDGs, a sustainable future will not be possible. We carefully listen to the voices of society and open up the possibilities of materials. With these as our Company’s founding principles, we will advance sustainability initiatives under President Shimizu and contribute to increasing corporate value and achieving a sustainable future.

We kindly ask for the continued support and understanding of all our stakeholders.



A handwritten signature in black ink that reads "T. Ishiguro".

Takeshi Ishiguro

Chairperson of the Board of Directors,
Representative Executive Director



The press conference announcing the change of president
(February 2023)

Editorial policy

As a reporting tool to explain its efforts to contribute to sustainable development from a long-term perspective based on ESG, Daido Steel Co., Ltd. initially published an Environmental Report, which was replaced in 2006 with the CSR Report, and then in 2020 with the Daido Steel Sustainability Report. From 2021, we have been publishing an integrated report that can comprehensively communicate the Company's value creation process, strategies, and materiality progress for realizing an increase in corporate value in the medium- to long-term, as well as the Company's initiatives in general.

We expect the readers of this report to be the Company's stakeholders (customers, local communities, shareholders/investors, suppliers, employees, etc., all persons related in company business), public institutions, media, and educational institutions, etc. The scope of this report covers Daido Steel Co., Ltd. and its group companies, and mainly contains information related to "strategy" and "sustainability" from a long-term perspective.

Reporting period

April 1, 2022 to March 31, 2023 (includes some fiscal 2023 activities and past results)

Referenced guidelines

VRF "Sustainability Reporting Standards"

IFRS Foundation "International Integrated Reporting Framework"

Ministry of the Environment "Environmental Reporting Guidelines 2018"

Ministry of Economy, Trade and Industry "Guidance for Collaborative Value Creation"

Publication date

September 2023 (last published in September 2022)

Thoughts behind the cover design

The design combines a bridge-like pattern and the slogan "Beyond the Special."

This represents our conviction that by offering "value that goes beyond the special," we provide a "bridge" that leads to everyday life and industrial development. At the same time, the design symbolizes Daido Steel Group as a team striving to reach our targets as one on a global scale.

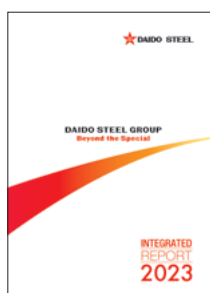

Introduction

Foreword	1
Corporate Philosophy Structure/Business Direction for Corporate Value Enhancement	3
Message from Top Management	5

Daido Steel's Value Creation Story

107-Year History of Daido Steel	11
Overview of Daido Steel Group	13
Relationship of Daido Steel and Society	15
Value Creation Process	17
Daido Steel's Core Competency Creates "Value That Goes beyond the Special"	19
One Year at Daido Steel	21
Financial/Non-financial Highlights	23

Innovation to Realize a Green Society

Sustainability Management	25
Sustainability Basic Policy and Materiality	29
2023 Medium-Term Management Plan Progress	31
R&D and Intellectual Property Strategies	35
Manufacturing Technology Strategy	39
Human Resource Strategy	43
DX Strategy	47
Financial Strategy	51
Business Strategy: Specialty Steel Business Division & Tool Steel Business Division	55
Business Strategy: Fabricated Materials Business Division	57
Business Strategy: Functional Products Business Division	59
Business Strategy: Machinery Division	61

Contribution to Realizing a Green Society

Response to Risks and Opportunities	63
Progress of Actions for SDGs and Materiality	65

Preservation of the Global Environment

Initiatives to Address Climate Change	67
Transition to a Circular Economy	71
Helping to Protect the Global Environment with Daido Steel's High-performance Products and Technology	73

Responsibilities and Contributions to Society

Respect for Human Rights	75
Elimination of Occupational Accidents	77
Promotion of Health and Productivity Management	79
Promotion of Diversity	81
Work Style Reforms	84
Social Contribution Initiatives	85
Supply Chain Management	87

Strengthening Governance

Discussion between Outside Directors and Chairperson of the Board of Directors, Representative Executive Director	89
Strengthening of Corporate Governance	93
List of Officers	99
Risk Management	101
Compliance	104
Stable Supply of High-quality Products	107
Stakeholder Communication	109

Corporate Data

Ten-year Financial Summary	111
Company Overview	113
List of Group Companies	114

Corporate Philosophy Structure

Daido Steel Way

The Daido Steel Group aims to enhance corporate value by practicing the Daido Steel Way (corporate philosophy structure), which systematizes its vision and the basis of its actions.

Beyond the Special

From the past to the present, we have continued to support our future. In order to do this, we will continue pursuing materials' potential and **what is beyond the special**.

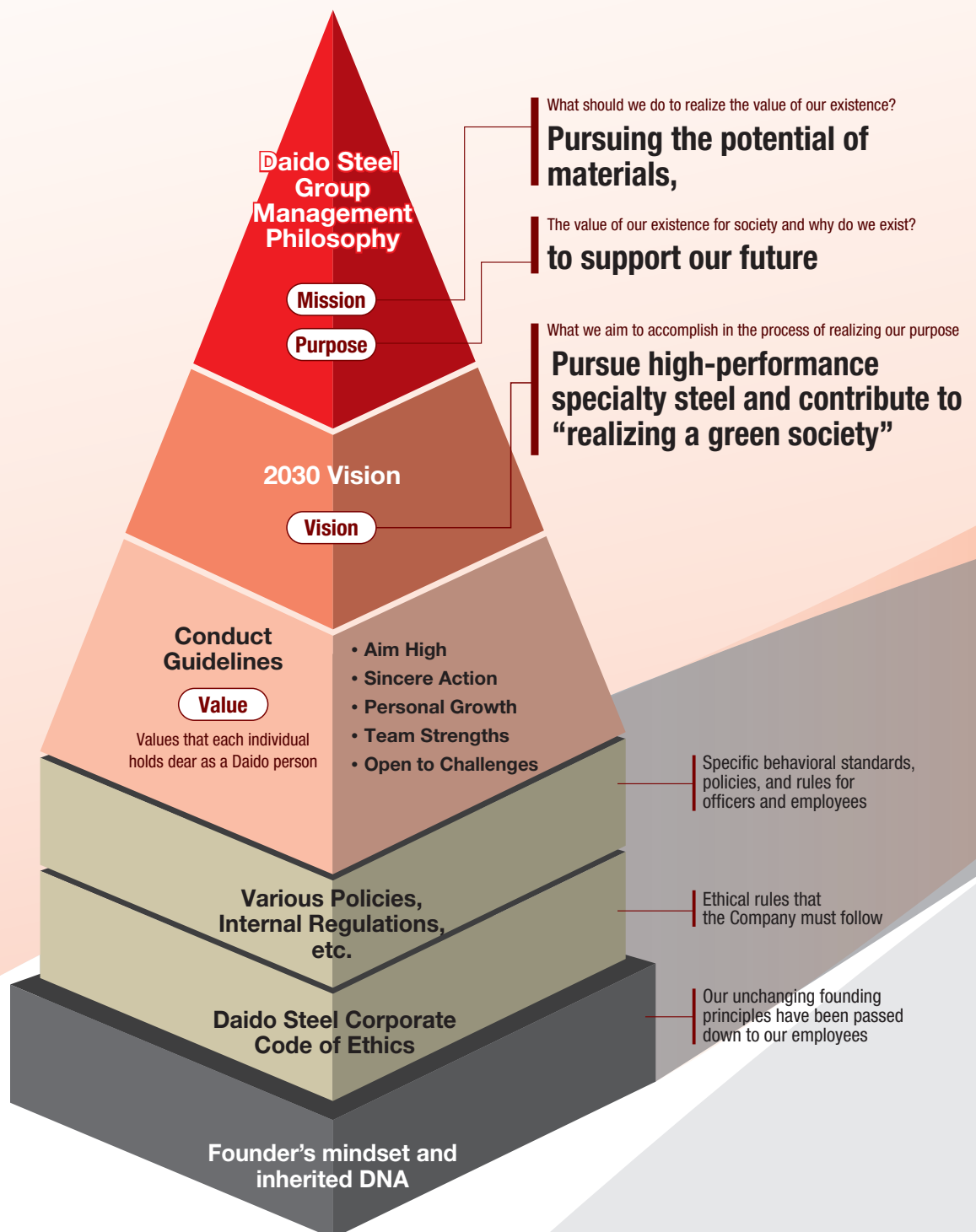

Business Direction for Corporate Value Enhancement

Looking toward carbon neutrality in 2050, the Company aims for a 2030 vision to "Pursue high-performance specialty steel and contribute to 'realization of a green society'."

We will further strengthen our relationship with stakeholders and make efforts to realize our vision together.

Realization of Management Philosophy

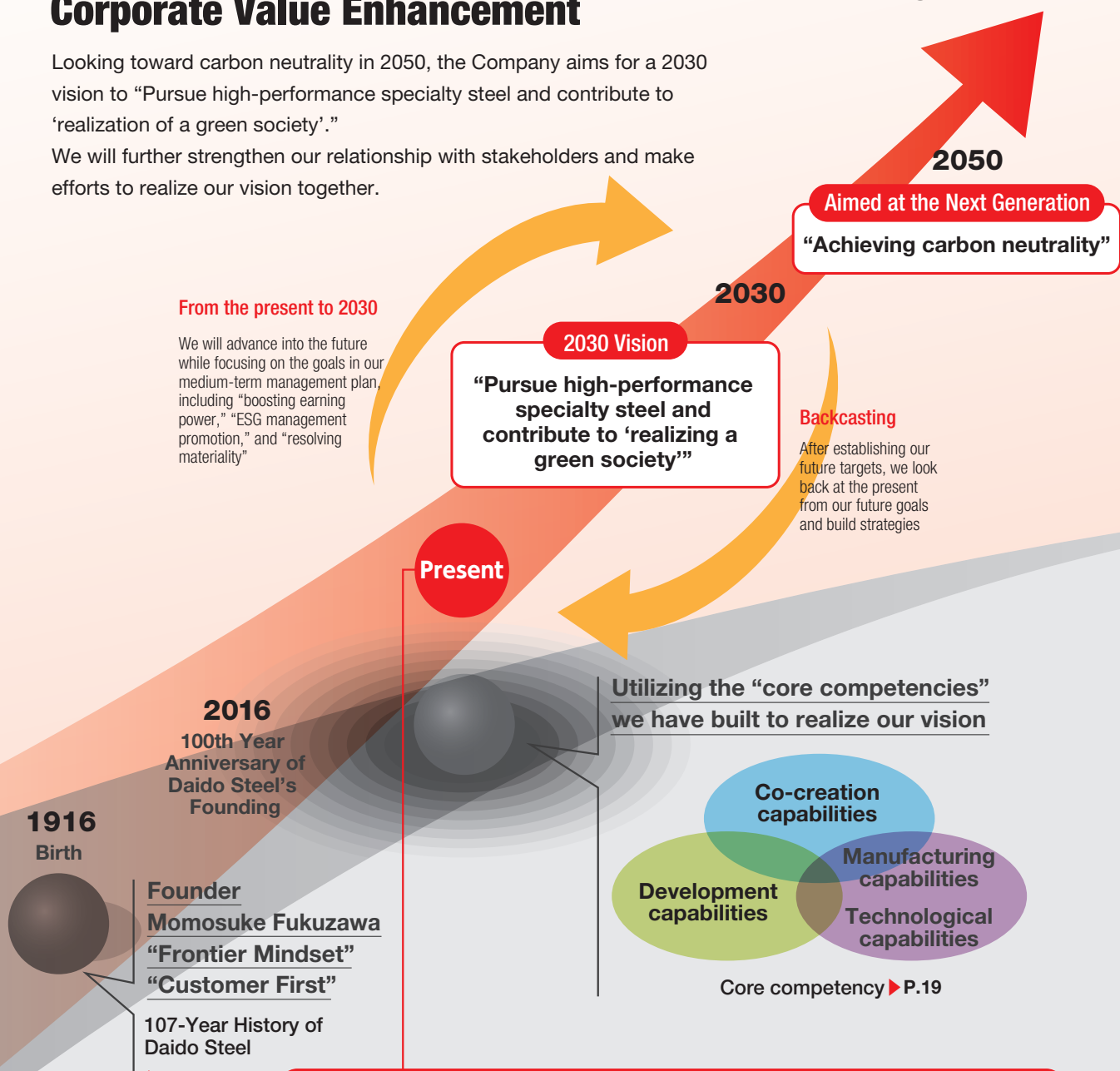

From the present to 2030

We will advance into the future while focusing on the goals in our medium-term management plan, including "boosting earning power," "ESG management promotion," and "resolving materiality"

2030 Vision

"Pursue high-performance specialty steel and contribute to 'realizing a green society'"

Backcasting

After establishing our future targets, we look back at the present from our future goals and build strategies

Present

Utilizing the "core competencies" we have built to realize our vision

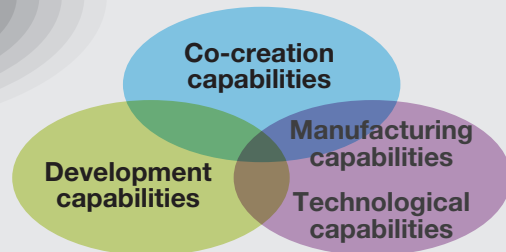

Core competency ▶ P.19

2016
100th Year Anniversary of Daido Steel's Founding

1916
Birth

Founder
Momosuke Fukuzawa
"Frontier Mindset"
"Customer First"

107-Year History of Daido Steel
▶ P.11

2023 Medium-Term Management Plan & the Next medium-term management plan

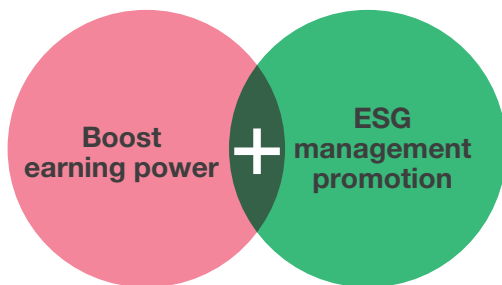

2023 Medium-Term Management Plan ▶ P.31

Resolving materiality

1. Preservation of the global environment (business activities)
2. Preservation of the global environment (product supply)
3. Responsibilities and contributions to society
4. Strengthening governance

Materiality ▶ P.30

Top Message

We will continue to provide our we support our future.

My name is Tetsuya Shimizu. I assumed the presidency of Daido Steel Group in June 2023.

Throughout our Company's 107-year history, we have supplied specialty steel tailored to the needs of each era while adhering to the "customer first" philosophy of our founder, Momosuke Fukuzawa. From our founding until the 1950s, amidst war and other crises, our operations spanned a variety of business sectors. These included manufacturing goods for the military as well as the general public. The Company continued to grow from the 1960s onward, when the use of automotive vehicles grew more prevalent. This era saw technological advances and increased vehicle production, which likewise increased demand for specialty steel materials in automotive components, such as engines and transmissions.

Today, society is entering a new era as it transitions toward decarbonization. The landscape of specialty steel demand is again experiencing major changes. We must sail the seas of change as well. Whatever direction society takes, specialty steel will remain an essential material that upholds social infrastructures. Our Company has an important mission to stay abreast of changes and continue to provide "special value"—namely, the materials that society needs going forward. We will fulfill this mission without forgetting our founding philosophies of putting "the customer first" and "working closely with customers—that is, society—to anticipate their needs." As I lead this Company, I will encourage employees in every position to continue to adhere to these philosophies.



Tetsuya Shimizu
President & CEO,
Representative Executive Director



customers with special value as

Mission as President

I have worked in research and development for many years. Rather than our primary type of specialty steel, which is structural steel for automotive applications, I was involved in developing what our Company calls “high-performance materials,” including stainless steels and superalloys. I developed and proposed materials after listening to what customers wanted and thinking about what materials would match their needs.

One of the most memorable experiences I had was when I was involved in the development of stainless steel (DHS1) for hard disk drives (HDD) in 1998. I witnessed firsthand how different that industry’s timelines and approaches were from the automotive industry. A month for us was like a year for them. For example, a lead time of three months to develop and produce a steel sample was viewed as outrageous. It impressed upon me the importance of understanding an industry’s sense of speed and culture when attempting to expand into or enter that industry. During that experience, I was also struck by Daido Steel Group’s extraordinary ability to work together as unified whole. The factories, sales teams, technical services, Corporate Research & Development Center and overseas subsidiaries all worked on steel development as one to make sure the customer’s expectations were met. The factories were

particularly quick to modify equipment or change processes. Though we encountered some difficulties in the beginning, we managed to recover and surpass our competitors, eventually producing what became the world’s de facto standard. The experience showed me how we can be more powerful than we imagine when we work together. The reason we were able to come together as one was because of our shared mission to meet customers’ needs. It’s rooted in our Company’s DNA. We have to stay true to our roots, putting “our customers first” and “working closely with them—that is, society—to anticipate their needs.”

In 2014, while heading the marketing department as the General Manager of the Material Solutions Department, I was involved in the challenging tasks of increasing sales in new markets and identifying business opportunities for all of Daido Steel Group’s products. Initially, we had difficulty bridging the gaps between different business divisions, but it was a valuable experience to see how collaboration improved as we worked together, broadening perspectives and eventually leading to a change in company culture. I believe it is my mission to use these experiences to help our Company more rapidly identify practical uses for new products as well as launch and grow new businesses.

We are going to produce the materials that our customers and society need.



Endless Possibilities Forged by Specialty Steels

Specialty steels are essential to our lives but are usually hidden from view. They can be found in computer and automotive components and are also in devices and equipment used in applications like power generation and construction. As a material, specialty steels are so essential, that if they were to disappear, our current way of life would disappear with them. In fact, even the part that supports the ball in everyday ballpoint pens is made from our Company's specialty steel. Japanese ballpoint pens are renowned around the world for their smooth writing capabilities and long product lifespans. This is because highly precise and complex processing is applied to the stainless steel used in them to maintain its high performance. Specialty steels have numerous applications like this, and the ways they can be combined open up endless possibilities.

The value of specialty steels resides in their incredible functionality. There are many materials available, but specialty steels stand out for their exceptional variation and design characteristics. The functionality required of steel has changed dramatically with each new era, but our Company has supported society's progress and development by closely following customers'—or rather, society's—needs over time and maintaining a frontier mindset in the face of diverse changes. Using our manufacturing processes for high-mix, low-volume production, our Company's competitive edge is clear in how much we can cut costs and the value we deliver to meet customers' needs.

Today, changes in the global climate are greater and more severe than ever before. New demands and high

expectations are being placed on the functional superiority of specialty steels. In particular, society is changing in many ways as it moves toward decarbonization, such as shifting to electric vehicles and clean energy sources. Many obstacles lie on the path to becoming a green society, and our Company cannot overcome them alone. We will work in partnership with all our stakeholders and with a profound sense of mission due to our position at the very top of the supply chain.

The global supply chain is being rebuilt as the U.S. and China decouple their economies. We are building a more stable supply chain that relies on domestic procurement to help us fulfill our mission from the standpoint of economic security and increase our business opportunities. In practical terms, the government has defined 11 “specified important goods” that are critical for survival, as they are widely depended on by the citizens of Japan in their daily lives and in their economic activities. Among these, permanent magnets, semiconductors, and aircraft components overlap with our Company's priority growth products. Also, storage batteries, machine tools, industrial robots, and ship components are categories of goods that make heavy use of our Company's specialty steels. We supply materials to a wide range of industries, including automotive, aircraft, energy, industrial machinery, electronics, and medical devices. It is extremely important for the medium- to long-term growth of both Japan and Japanese companies through Japanese manufacturing that we make our supply chain more resilient. This will ensure we fulfill our supplier



We always aspire to deliver value that goes beyond customers' needs.

responsibilities to overseas and domestic customers—as well as industry as a whole. We will also help improve our supply chain's resilience in all aspects of all our business

activities, including technological development, equipment investment, and personnel acquisition and training.

Realizing a Green Society

Efforts to curb global warming have grown more serious, and societal structures are being transformed as we move toward the goal of reducing CO₂ emissions. In the future, electric vehicles (EV) are expected to become more prevalent, and hydrogen is attracting attention as a clean energy source. Demand for semiconductors is also expected to see medium- to long-term growth to accommodate increased digitalization, in fields like information and communications. In line with these changes, many products are likely to have higher demand in the future, specifically CASE-related products, like steel used to make gears in e-Axle gear reducers, magnets for EV motors, high-performance soft magnetic materials, and anode materials for lithium-ion batteries. Further, hydrogen embrittlement resistance steel holds promise in the fields of semiconductor-related products and clean energy. We are currently developing these materials while using equipment that can assess material properties to ensure they meet customer needs. We share these assessment results with customers throughout the process.

I would like our Group to particularly focus on magnetic materials and hydrogen. We already have a picture of the uses and demand for magnetic materials, and how we develop these technologies and businesses going forward will be crucial to our success. Conversely, societal applications of hydrogen are not widely understood, and our objective at this point is to explore what we can do in the hydrogen sector and expand our opportunities. Turnaround times in these fields differ, but we can expect changes in societal structures to generate greater demand in the future, and we will help build a green society by ensuring customers are provided with the materials they need.

Our key management concerns as we try to avoid falling behind the tide of change in carbon neutrality and other green initiatives are how fast we can change and how short we can make the time between when we realize we have to change and when we actually change. Fields requiring our

specialty steels are going to expand as we move toward a green society. This will not be limited to the automotive industry, and our relationship with the industrial machinery and electrical/electronic industries as well as the energy industry will become more important. We have to change our mindsets and behaviors and adjust our development to match the pace of change in each industry. It is going to be very challenging to change our mindsets and behaviors, but all our employees have to embrace this mentality for us to enter new fields. We are also promoting the use of digital transformation (DX) tools, including AI, as a means of updating our mindsets and behaviors and also to increase our speed of change.

Please see the medium-term business plan on page 31 for recent business performance trends.



Strengthening Sustainability and Governance

Efforts to reduce the amount of CO₂ emitted from our operations is also critical to realizing a green society. Our Company melts scrap iron in electric furnaces to manufacture specialty steels. This method emits about one-quarter the amount of CO₂ that methods using blast furnaces do. However, the electric furnace method consumes a significant amount of energy, and our manufacturing processes emit close to 900,000 tons of CO₂ annually. Nearly 90% of our total emissions come from electric and city gas utilities. Reducing and decarbonizing our electric and city gas consumption is the most important factor for us to become carbon neutral.

In response to this situation, we announced the Daido Carbon Neutral Challenge in April 2021 and set goals to cut our CO₂ emissions 50% from their 2013 levels by 2030 and to be carbon neutral by 2050. Two-thirds of our 900,000 tons of emissions are Scope 2*¹, and we plan to shift as much as possible to electricity generated by renewable energy. The remaining third is Scope 1*², and we plan to tap into the energy-saving technologies of our engineering department to improve the combustion efficiency of our

furnaces and increase productivity. We have a clear roadmap toward halving our emissions by 2030. To become carbon neutral by 2050, we need to participate in national and industry initiatives and keep an eye on new technological developments. Our strategy is to pursue economically rational options as we look for the best solutions.

In addition to environmental goals, we are steadily promoting due diligence and other initiatives in line with our new human rights and anti-bribery policies. In the realm of corporate governance, we have strengthened several measures, including transitioning to a company with an Audit & Supervisory Committee, instituting evaluations of the Board of Directors' effectiveness, reviewing officer remuneration, and improving succession planning. Going forward, I would like to focus on dialoguing with shareholders and investors, as this was difficult to do during the COVID-19 pandemic. I will lead the dialogue with overseas investors myself, using this integrated report as a tool to facilitate that dialogue.

*1 Scope 2: Indirect CO₂ emissions from using electricity or other forms of energy supplied by third parties.

*2 Scope 1: Direct CO₂ emissions from fuel combustion, etc.

Personnel Development through Mental and Physical Health

One reason our specialty steels have been so well received in global markets is our longheld commitment to always add our own original touches. This commitment extends to the factory floor. When we purchase manufacturing equipment, we alter it using our company's own original innovations before using it rather than installing it as-is. Our Company has persevered in development even when others around us were critical of our chances of success, which has resulted in us creating entirely new products, with some technologies even becoming widely used as industry standards. This company culture enables us to provide customers with considerable additional value through high-mix, low-volume production. We have employees who find this very rewarding, and they innovate relentlessly as an automatic part of their work. We believe employees are the source of our growth, and it is important to improve their mental and physical wellbeing. We also place a strong emphasis on personnel development and

diversity. Mental and physical wellbeing is the foundation of happiness, and I want employees to be conscious of that. I also encourage them to care about the health of their colleagues and families.

To aid in personnel development, we have been operating the Daido Steel Technical Training School since 1952. It was established as a training facility for new recruits who had graduated from high school. The school teaches basic knowledge and technical skills to cultivate experts in specialty steel manufacturing. It also supports students in building their own independent lives and prepares them to become businesspeople and members of society. The school educates employees through an intensive curriculum over a one-year training period. We are sometimes asked why we continue such an expensive program, but in my view this type of training is indispensable. We handle large equipment at our manufacturing sites, and employees must learn how to operate them safely. Also, acquiring a sense of social



I want us to be attentive to each employee's thoughts and opinions, taking into consideration their position and job responsibilities.

morality is critical personnel development not only for those in our company but also for society as a whole.

Diversity is also important. When I was working in the Material Solutions Department, I was in charge of marketing products in the Middle East and traveled to the area. The cultural norms there are completely different from Japan, and I struggled in several aspects of doing business. I learned to respond flexibly, without presuppositions, because people have their own values and ways of thinking. This experience impressed upon me how important diversity is.

It is getting harder in Japan to acquire good personnel because of our declining birthrate and aging society. It is

critical that we create a work environment where people recognize and respect each other's differences, regardless of gender, nationality, values, sexual orientation, or disability. This includes hiring women and foreign nationals, as well as strengthening our previously implemented year-round and mid-career hiring practices. For example, we are working to create an environment that is conducive to achieving our goal of doubling women in management positions by 2030 (from 15 to 30). We also have initiatives in place for global human resource development, like overseas training, study abroad and assistance in attaining qualifications.

To Our Stakeholders

Our Company engages in a broad range of business activities in the materials industry. We are confident that we will continue to evolve with society and are dedicated to building a better future for all its members. We embrace the challenges embodied by Daido Steel Group's slogan of "Beyond the Special" as well as our 2030 vision to "Pursue high-performance specialty steel and contribute to 'realization of a green society'." We will achieve this vision by promoting integrated group management, boosting earning power, and pursuing ESG initiatives. We are also committed to communicating our robust growth potential and indispensable role in society to all our stakeholders.

We invite you to share in our vision of future growth for the Daido Steel Group.

September 2023

Tetsuya Shimizu

President & CEO,
Representative Executive Director

107-Year History of Daido Steel



▶ Corporate philosophy and DNA



Founder Momosuke Fukuzawa

The founding mindset of Momosuke Fukuzawa (1916)

When founder Momosuke Fukuzawa became president of Nagoya Dento Co., Ltd., he established the "GOKAI JUSSOKU (Ten Guiding Tenets)" for employees.

1. The happiness we enjoy is thanks to the patronage of many customers
2. We must never forget the support from our customers even for a moment
3. The consumer's opinions are always right and should be treated hospitably
4. Absolutely prevent breakdowns and satisfy customers
5. Time and effort are precious and should be used with the greatest efficiency
6. Work that needs to be done that day should not be postponed until tomorrow
7. Even the smallest things should not be overlooked.
Even little things must not be lost
8. Debate and formality are trivial matters. Think about how to make a profit
9. Complaining and laziness are bad for your health. Do your job happily
10. This company succeeds or fails depends on whether we can unite as one.
Let's work together

On August 19, 1916, founder Momosuke Fukuzawa concentrated on the steel manufacturing industry and established Electric Steel Manufacturing Co., Ltd. with the aim of utilizing electricity from the Kiso River water system. After several mergers and reorganizations, the Company became Daido Steel Co., Ltd. in 1976, and continues to operate to this day. Over the past 107 years, we have overcome the changes of the times with the support of our stakeholders. We will continue to work together with everyone to contribute to the development of Japan's industry as a leading company in the specialty steel business, enrich people's lives, and contribute to society.

- Japan's high economic growth
- Two oil crises

- Plaza Accord

- Global financial crisis (Lehman Brothers bankruptcy)

- Great Eastern Japan Earthquake

- Post-COVID-19
- Decarbonized society

1970 1980 1990 2000 2010 2020

1976 Merger between Daido Steel, Japan Special Steel, and Tokushu Seiko to form a new Daido Steel



Presidents of the three companies at the merger signing ceremony

Net sales

Non-consolidated sales from FY1950 to FY1981
Consolidated sales from FY1982 onwards
Not shown because there is no data before FY1949

FY2022
Net sales ¥578.6 billion



Chita Plant at the time of completion

Metal Powder Plant



#1CC

1986 Establishment of small-sized rolling mill TEKISUN system

#1CC

1987 Installation of furnace F

1988 10tESR

1989 Steel bar solution heat treatment furnace

1990 10tVAR

1991 7tVAR

1991 7tESR

1993 VSR

1993 Wire pickling line

1994 Establishment of wire rod rolling mill TEKISUN system

1997 Blooming in-line press operation

1999 3t/9tVIM

2000 Established a tool steel flat bar e-Quality system

2006 6tVIM

2006 Titanium levitation melting furnace

2008 7000t press

2011 Concentrated small-size rolling operations at Kawasaki Plant

2012 Steel bar cutting processing relocated from Kawasaki Plant

2015 WBD1

2019 WBD2

2023 9tVAR

2023 9tVAR (two units)

2023 9tVAR

2016 VSR

2018 VSR2

2013 150t furnace installed (furnace A shut down)

150t furnace

2012 Renamed Kawasaki Techno Center

2002 Moved and renamed to Takiharuru Techno Center

1985 Metal Powder Plant began operations

1981 10t arc furnace

1971 Two 15t arc furnaces

1970 6tVAR

1971 2tESR

1971 2600t press

1977 3500t press

1987 NFP

1976 Wire rod rolling block mill

1970 Continuous steel bar annealing furnace

1968 Continuous SUS wire annealing furnace

1982 Plasma arc stacked solidification and melting furnace

1988 Established a tool steel processing and sales company in Taiwan

1994 Established a tool steel processing and sales company in Indonesia

1997 Established a sales office in Thailand (Bangkok)

2000 Established a sales office in China (Shanghai)

1970 1980 1990 2000 2010 2020

Establishment of management philosophy and conduct guidelines (1991)

- **Management Philosophy**
We will continue to make use of our people, advance our technology, and challenge the unknown in our effort to become a creative and innovative corporate group that contributes to 21st-century society.
- **Conduct Guidelines**
Become the nail that sticks out

Using the 100th anniversary as an opportunity, we updated our management philosophy, conduct guidelines, and created a group logo/slogan (2016)

- **Daido Steel Group Management Philosophy**
Pursuing the potential of materials to support our future
- **Conduct Guidelines**
Aim High/Sincere Action/Personal Growth/Team Strengths/Open to Challenges
- **Daido Steel Group Logo and Slogan**
DAIDO STEEL GROUP Beyond the Special



100th anniversary ceremony

Overview of Daido Steel Group

Daido Steel Group's overseas expansion destinations are displayed in orange.

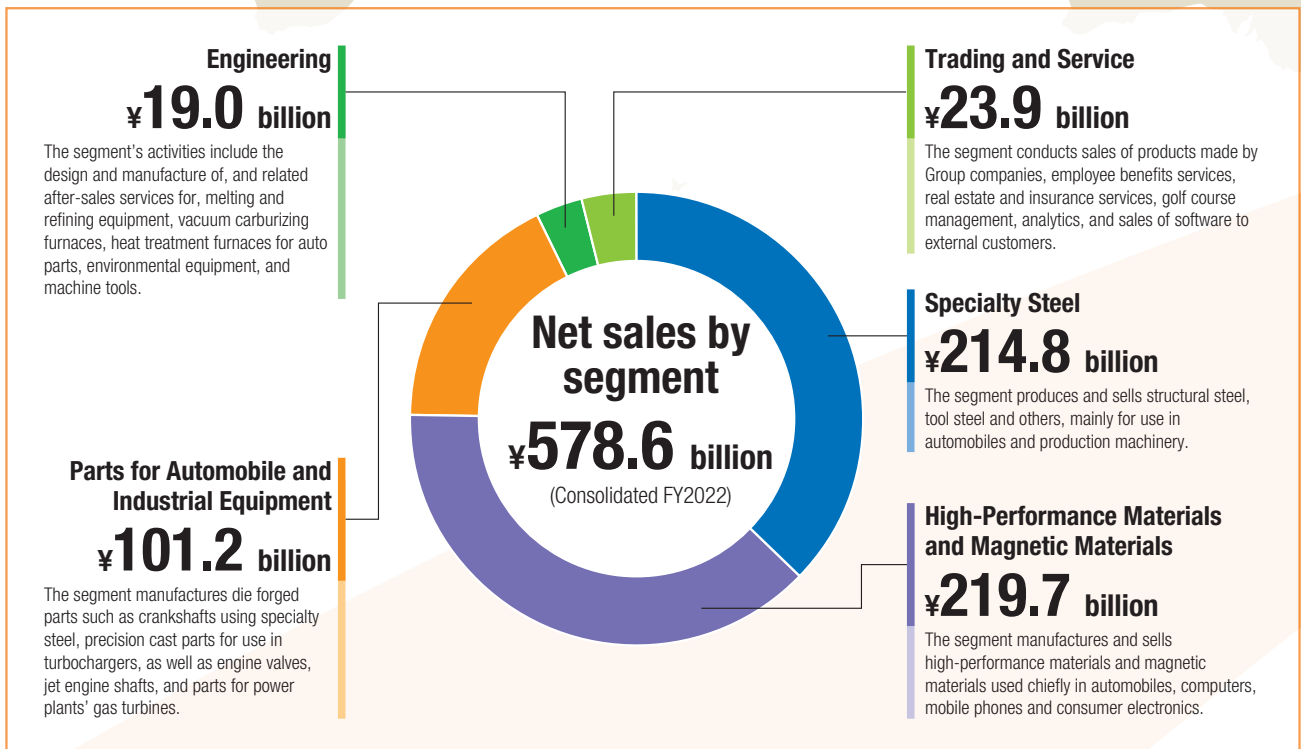

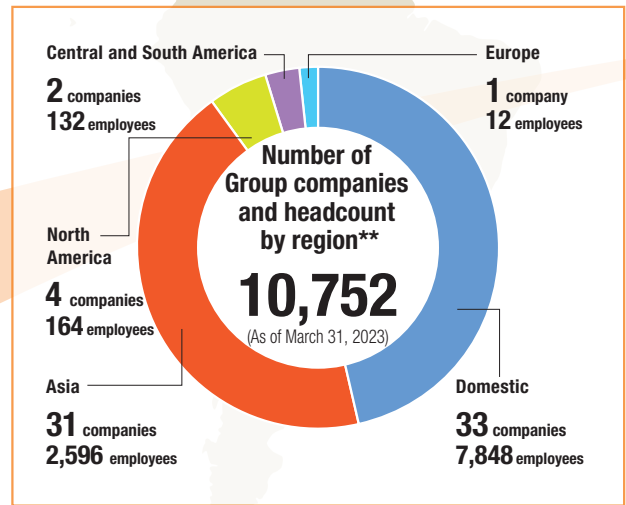
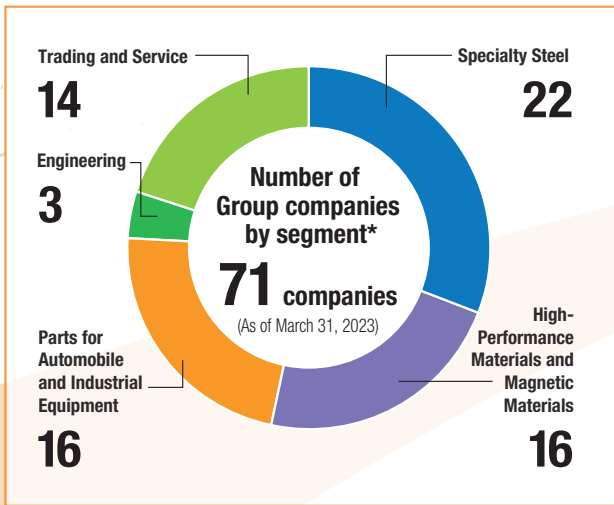

* Consolidated subsidiaries/affiliates

** Number of employees at consolidated subsidiaries and affiliates excluding Daido Steel

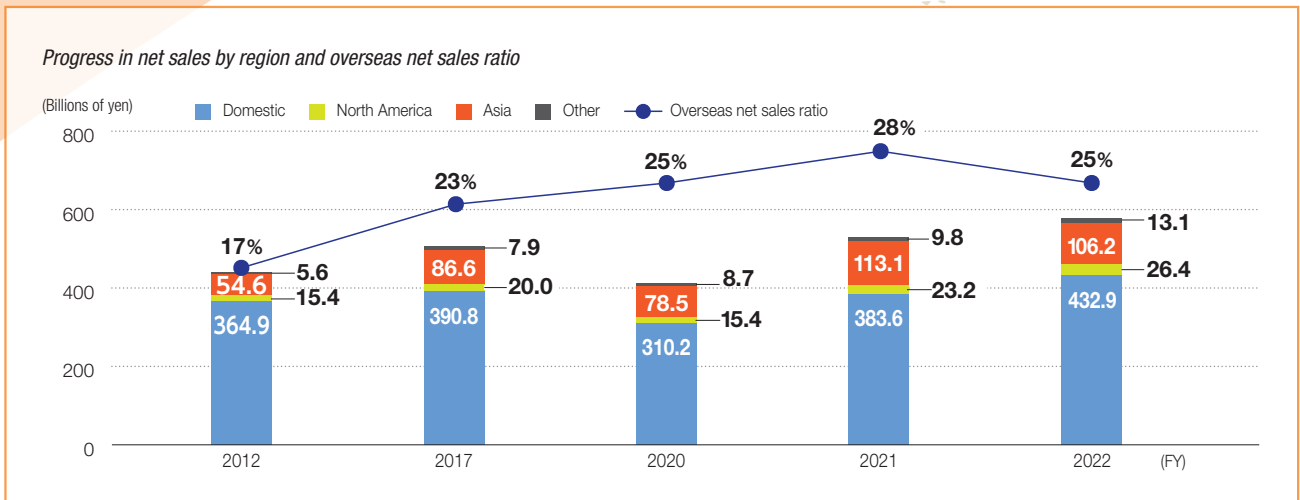

Relationship of Daido Steel and Society

The Daido Steel Group supplies society with steel-related products for a wide range of fields, such as specialty steel, high-performance magnets, and industrial furnaces. While not often seen by the general public, these products are used in automobiles, aircraft, power generation as well as medical treatments, etc. We play a role in increasing sustainability in industrial fields that help to support people's lives.



Jet engine shaft alloy

High-strength shafts with excellent durability help to reduce fuel consumption and increase the power output of aircraft jet engines, supporting safe air travel.



Medical titanium

Titanium has excellent properties such as being lightweight, non-magnetic, and bio-compatible. We provide materials that respond to various needs in the advancing medical field.

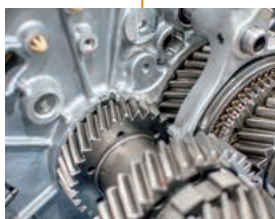

Gear steel

Gear steel combines high strength with durability to realize smaller, lighter automobile transmissions, helping to reduce environmental impacts such as CO₂ emissions.



Soft magnetic powder for reactors

Step-up reactors increase the voltage of batteries for hybrid vehicles. The iron core is formed from soft magnetic powder developed by Daido Steel, and can store a large quantity of energy. It also reduces energy loss and helps to reduce power consumption of the battery.



Neodymium hot deformation processed magnet MQ3

These ring-shaped magnets combine high magnetism with corrosion resistance, helping to realize quiet, smooth movement for industrial robots and contributing to the electrification of automobiles.

Daido Steel is striving to reduce weight, enhance strength, enhance corrosion resistance, and lengthen life-spans of various products to contribute to the reduction of CO₂ emissions in the world.



STARPAS® permalloy foil

We offer ultra-thin permalloy foil (thickness 10µm or more) with excellent workability and flexibility that is suitable for high-frequency magnetic shields and yokes.

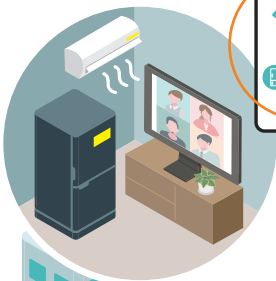

Stainless steel for ballpoint pen tips

The part that supports the ball at the tip of the ballpoint pen is made by carving highly corrosion resistant stainless steel. By imparting properties that make it extremely easy to carve, it is possible to perform complex machining with high precision, resulting in clear lettering and long life.



Vacuum carburizing furnace "SyncroTherm®"

Makes automobile components stronger and more lightweight by heat treatment by vacuum carburizing techniques, achieves small-lot production and ultimate on-demand, and supports smart factories.

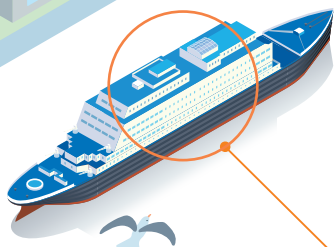

Ship diesel engine valves

We develop and provide nickel alloy valves with excellent high-temperature corrosion resistance to assist stable navigation as NO_x and SO_x emissions rules for ships become more stringent.

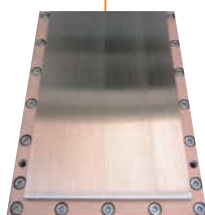

Target material for blackening layer "STARMESH®-γ1"

We have developed a new target material for metal mesh blackening layer for use in automotive touch panels, folding touch panels, 5G transparent antennas, 5G transparent noise shields, etc. This material has low reflectivity, excellent discoloration resistance and etching properties, and contributes society as an IoT supporting technology.



Ultrafine stainless steel wire

Thinner*, stronger, high-precision steel wire supports the advancement of a digital society.

* We manufacture stainless steel wire that is 11 microns in thickness, much thinner than human hair (approximately 50-100 microns).

Value Creation Process

Pursue high-performance specialty steel and contribute to “realizing a green society” in 2030

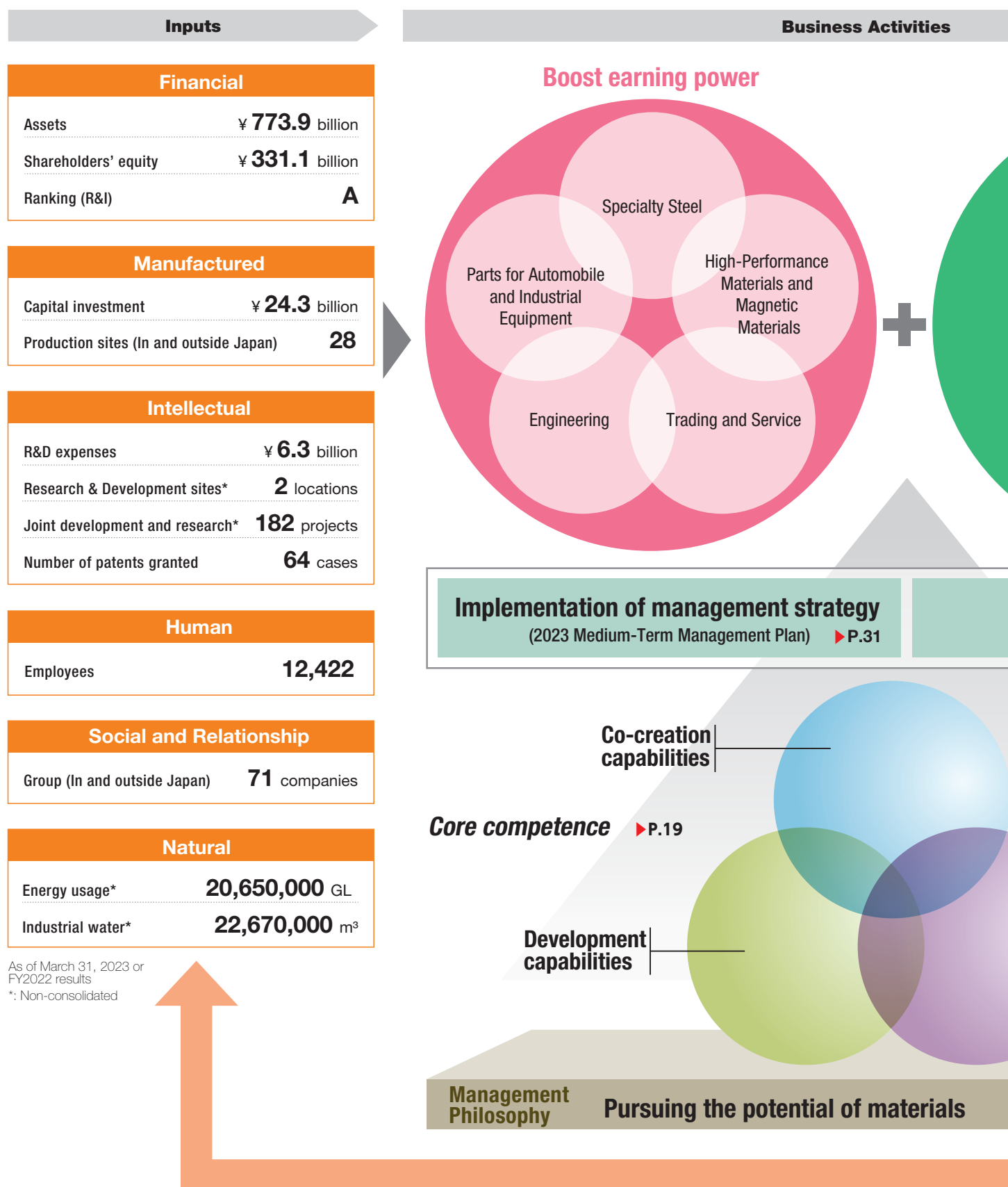

Since the founding in 1916, the Company has, along with the customer, continued to conduct manufacturing that contributes to innovation that society needs. Through manufacturing that maximizes the diverse management resources held by the Company, we aim to improve corporate value while progressing with ESG management that realizes a sustainable society. Daido Steel will continue to be a company that generates "value that goes beyond the special" under the banner of the slogan "Beyond the Special" to exceed stakeholder expectations.

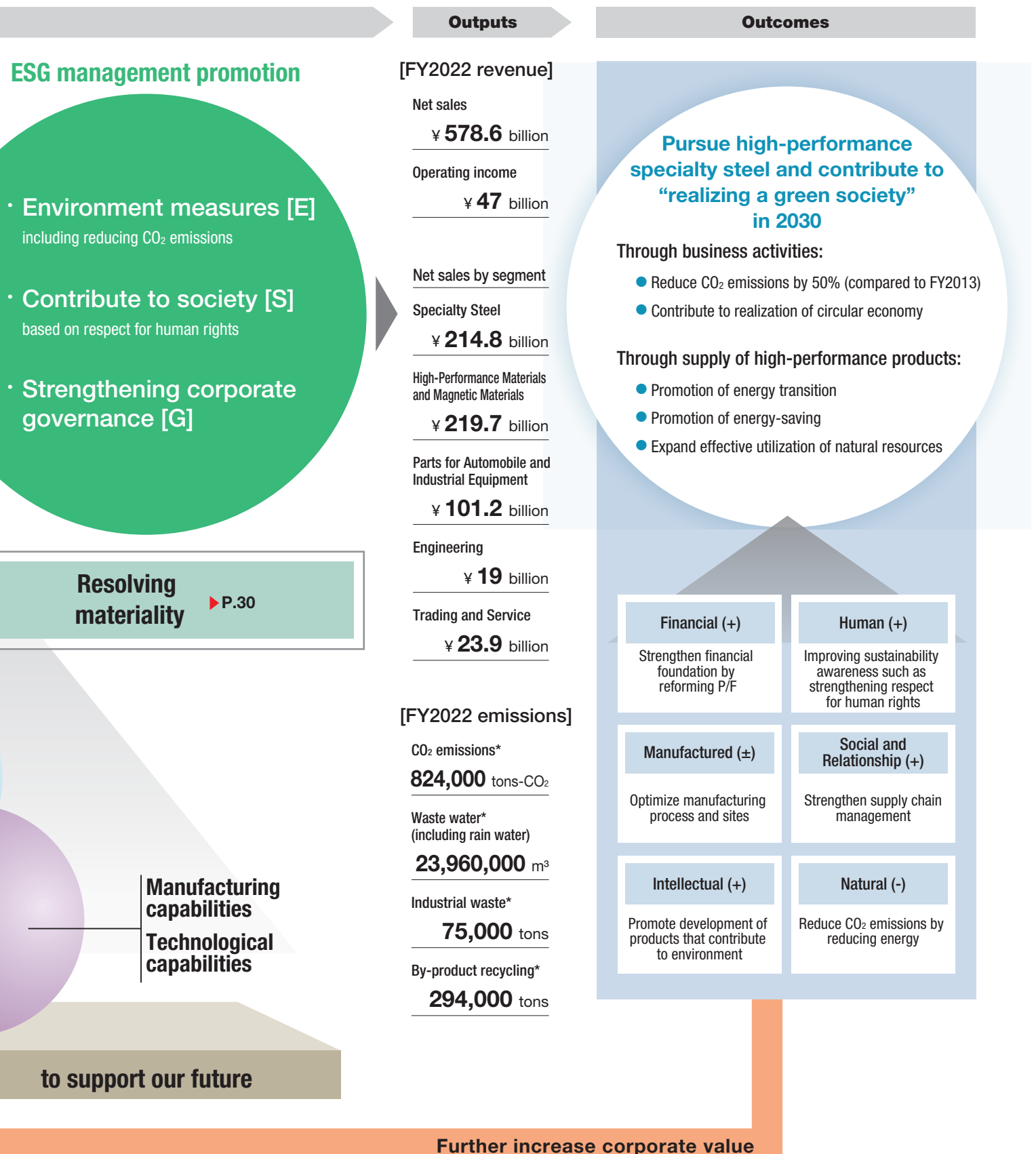

Daido Steel's core competency creates "value that goes beyond the special"

Daido Steel has the following three core competencies that it has cultivated over its 107-year history.

- "Co-creation capabilities to listen to customers' needs and take on new challenges"
- "Diverse high-performance materials and related development capabilities"
- "Manufacturing/technological capabilities to realize highly reliable products"

We will continue to take on the challenge of creating new value while solving social and customer issues by making full use of the strengths we have cultivated through the implementation of our five conduct guidelines.

Diverse high-performance materials and related development capabilities

R&D personnel
(as of the end of March 2023)
300

R&D expenses
(FY2022)
¥ 6.3 billion

- R&D is split between the materials realm, which is comprised of specialty steel*1 and magnetic materials, and the production process realm. In the existing business area, we are developing materials such as specialty steel and superalloys, which are our core realms of business technologies. We are promoting material development that integrates component design and manufacturing process technology.
- In recent years, we have strengthened our development system for magnetic materials and functional products with a view to the electrification of automobiles and the development of information and communications. We are also focusing on commercializing new products such as hot-working processed neodymium magnets used in motors in electric vehicles and soft magnetic powder used in boost reactors.

*1: Steel for high-strength gears for automobiles, electromagnetic stainless steel for automobiles, clean stainless steel for semiconductor manufacturing equipment, maraging steel for aircraft shafts, titanium alloy for consumer medical use, nickel alloy for drilling, etc.

Initiatives to maintain and improve "development capabilities"

- Anticipating the needs of future society and expanding basic technology
- Introducing AI technology to further utilize accumulated material development capabilities
- Accelerating the development of new fields through partnerships with universities, research institutes, and other companies

Promote new business development by acquiring new technology and patents

Progress of the number of patents granted

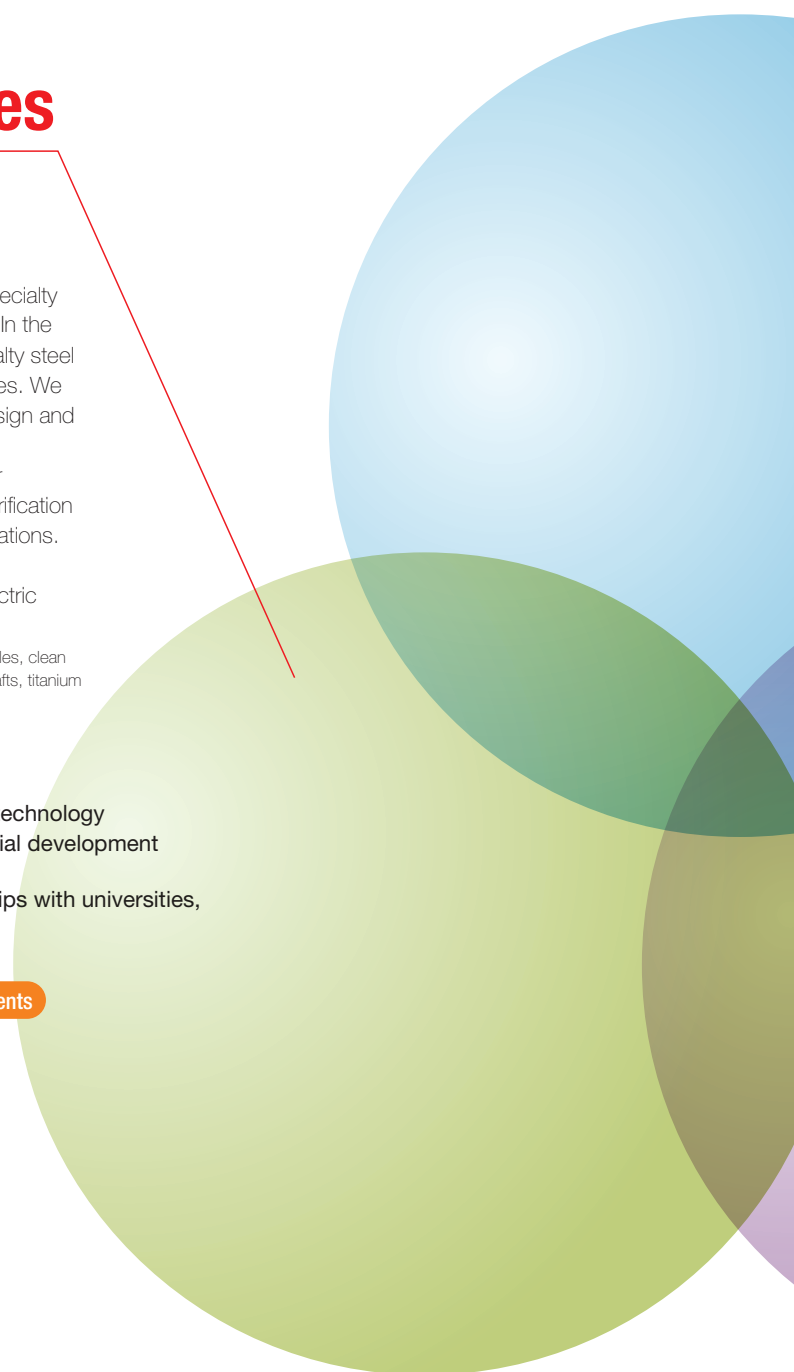
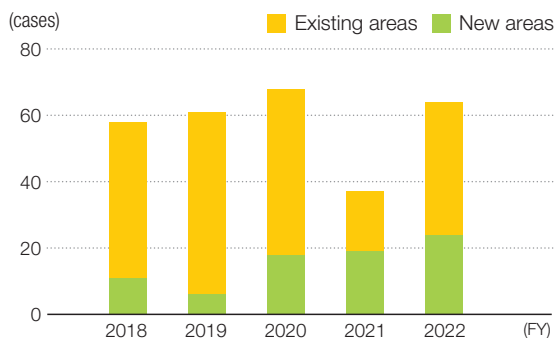

Co-creation capabilities

to listen to customers' needs and take on new challenges

Joint development
with customers
(as of the end of March 2023)

137 projects

Joint research with third parties
(as of the end of March 2023)

45 projects

● Specialty steel, functional products, fabricated materials:

We have long maintained deep relationships with customers in the automotive, heavy electrical, industrial machinery, and aviation industries, and have worked on many themes related to improving heat and corrosion resistance and increasing efficiency. In recent years, we have been actively working on the co-creation of advanced materials (machine, electronic, semiconductor, hydrogen, etc.) to realize a green society.

● Machinery:

We are actively promoting joint development with national and public organizations on many themes, such as our "Super-High Temperature Carbonization Technology Demonstration Project" which was selected as part of the Breakthrough by Dynamic Approach in Sewage High Technology Project (B-DASH Project).

Initiatives to maintain and improve "co-creation capabilities"

- Realizing "co-creation" through development in collaboration with customers
- Launch of Next-Generation Product Development Center to promote carbon neutrality with customers (functional products)
- Machinery Division that turns ideas born from customer feedback into reality

Close internal and external collaboration

Joint development scheme overview

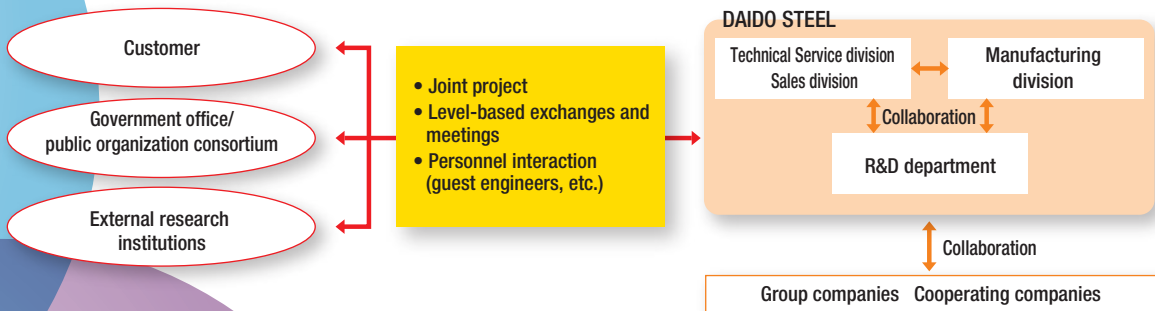

Manufacturing/technological capabilities

to realize highly reliable products

Types of products handled
(material X shape type, FY2022)

About **4,000** types

Number of improvements in
self-management activities
(number of improvement proposals, FY2022)

13,400 cases per year

- Daido Steel manufactures a wide variety of specialty steels using proprietary equipment and technology*² to provide materials that precisely meet customer needs. We are able to achieve steady reproducibility because of the advanced manufacturing capabilities we have accumulated over the years.

*²: Large rotating electric furnace, composite refining, round section vertical continuous casting, chance-free & precision rolling, difficult-to-process wire rod rolling, combined process using free forging press and radial forging machine, etc.

Initiatives to maintain and improve "manufacturing capabilities" and "technological capabilities"

- Improving manufacturing technology through collaboration and analysis with the Process Technology Research Department
- The workplace encourages its own improvements (self-management and TPM activities), which are pushed even further by Daido Monozukuri Kaikaku (DMK) efforts.
- Supporting manufacturing capabilities with high-quality manufacturing education (Daido Steel Technical Training School)

One Year at Daido Steel

In fiscal 2022, we added plant equipment and continued with new construction in order to “**boost earning power**,” and strengthened our manufacturing system for high-quality steel, for which demand is expected to increase in the future. We also promoted sales and volume production of new products that contribute to the IT area and CASE, and the practical use of our products by applying hydrogen technology.

As part of “**ESG management promotion**,” we have created a system to promote ESG initiatives by establishing a Sustainability Committee. We also participated in domestic and international initiatives, disclosed information (TCFD, CDP, 30by30 Alliance for Biodiversity), and established and published human rights policy.

Boost earning power

Vanadium-free titanium alloy that contributes to SDGs and is registered with the ASTM standards, the world's most prominent standards

Launch of Materials Open Platform for Permanent Magnet by National Institute for Materials Science (NIMS) and four magnet manufacturers

Special melting equipment added to Shibukawa Plant



New production line for point source LEDs for optical encoders and photoelectric sensors begins full operation

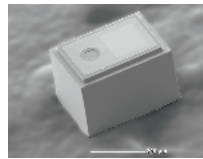

Release of a die steel-based 3D printer metal powder that is compatible with large mold manufacturing

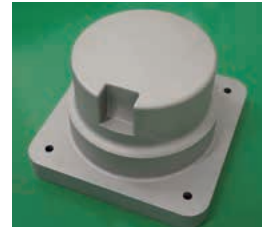

A three-dimensional view of the behavior of micro magnets inside cutting-edge permanent magnet materials

2022 Apr. May Jun. Jul. Aug. Sep.

Establishment of the Sustainability Committee

Advisor Masato Sagawa receives the IEEE Medal of Honor

Information disclosure based on the recommendations of the Task Force on Climate-related Financial Disclosures (TCFD)



Issuance of transition bonds

Publication of sponsored research reports

Secondary processing hub in Thailand holds opening ceremony —Reinforcing the supply chain of high-performance materials in ASEAN



ESG management promotion

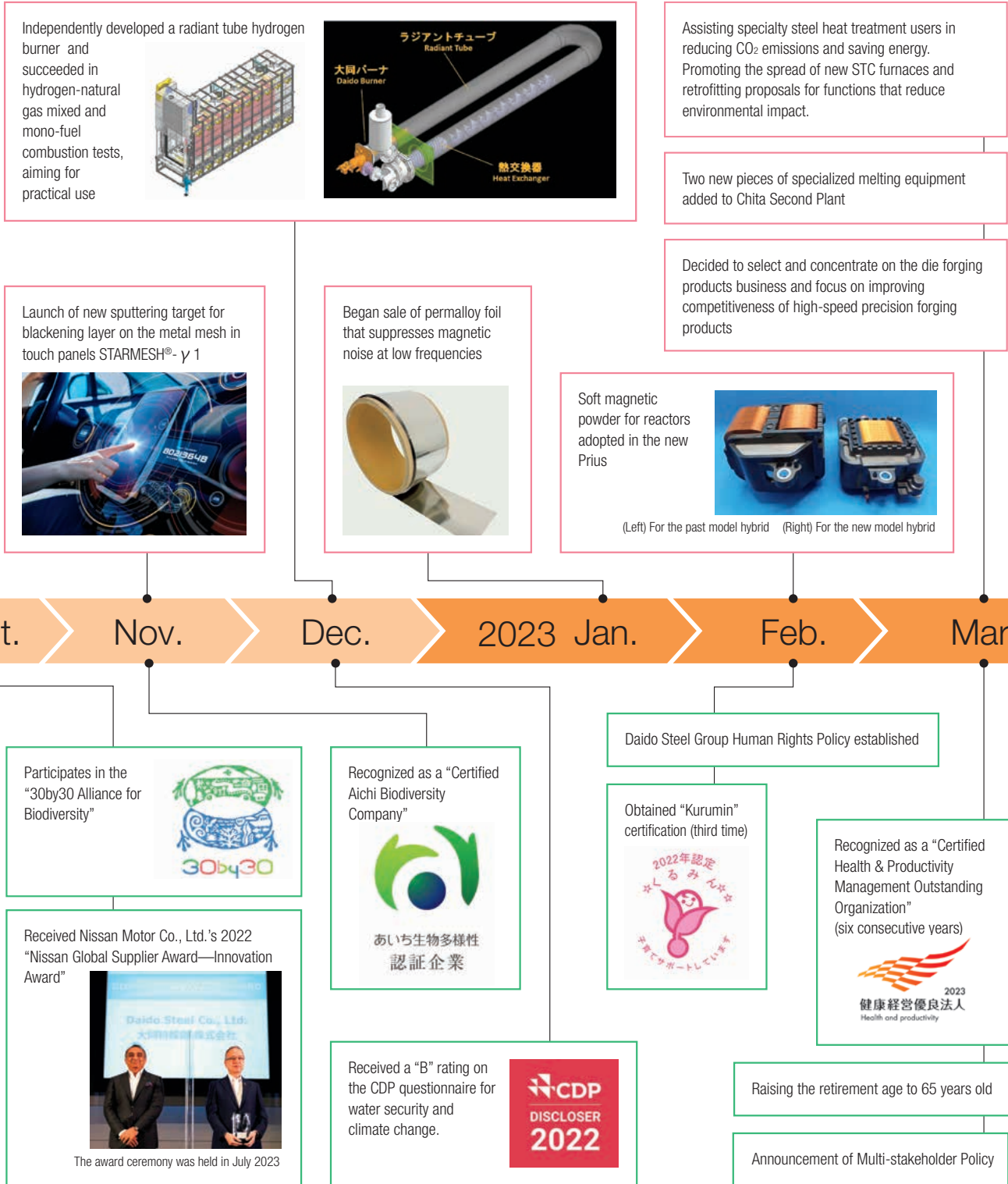

Financial/Non-financial Highlights

Financial performance (Consolidated)

Net sales and operating income

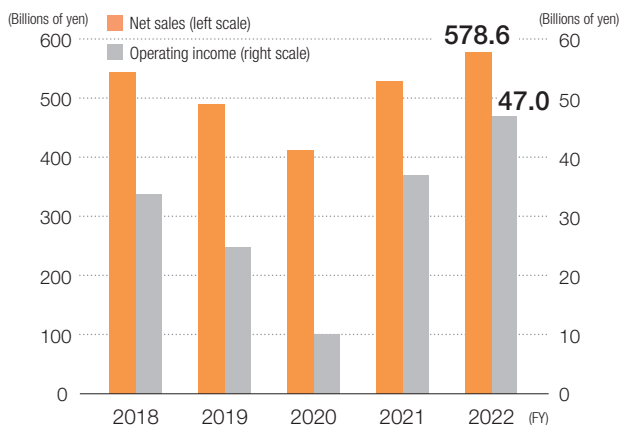

Profit attributable to owners of parent and ROE

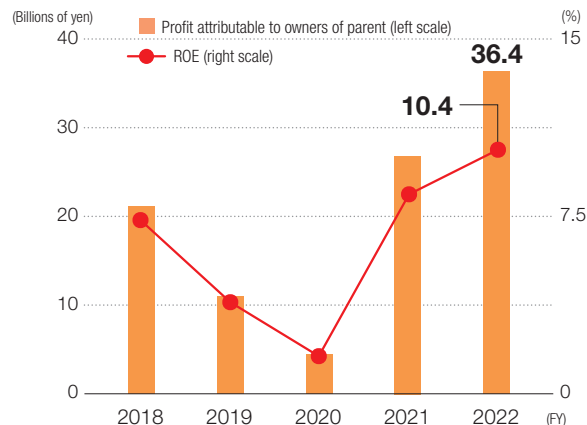

Return on sales (ROS)

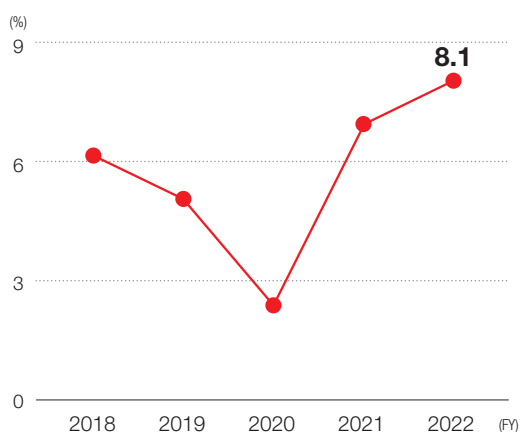

Return on assets (ROA)

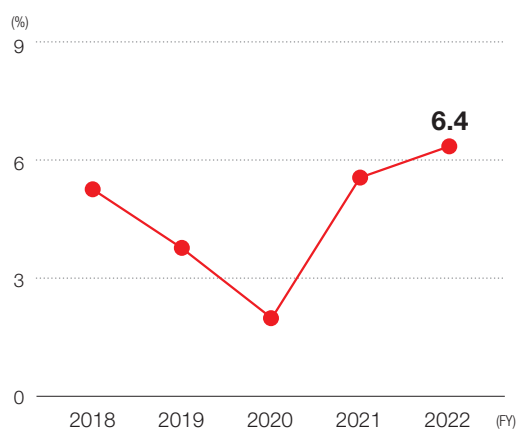

Capital investment (construction base)

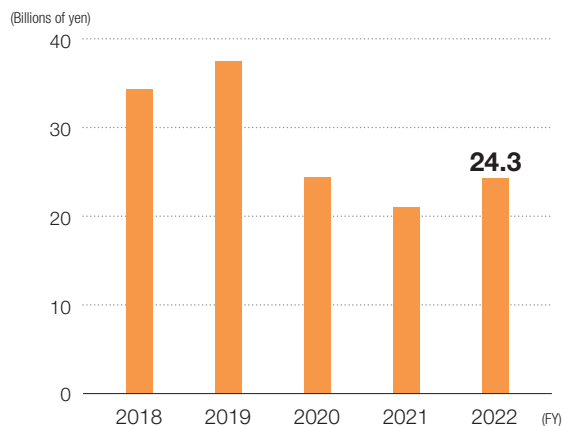

Dividend

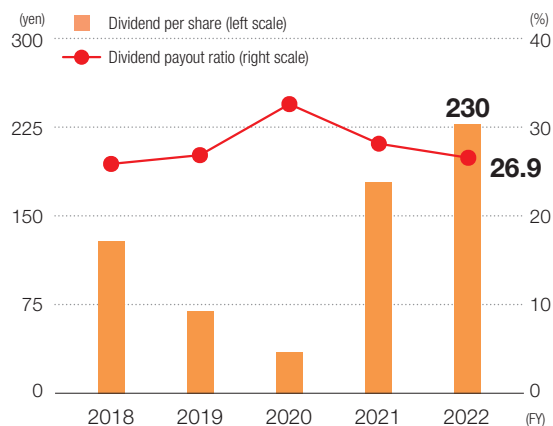

Non-financial performance (non-consolidated)

CO₂ emissions and emissions intensity

For details, see ▶ P.67

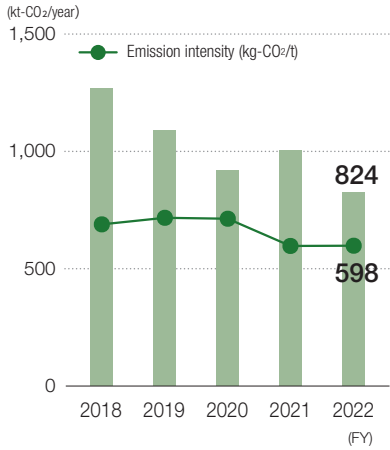

Amount of capital invested on energy-saving facilities* * Cumulative total from 1996

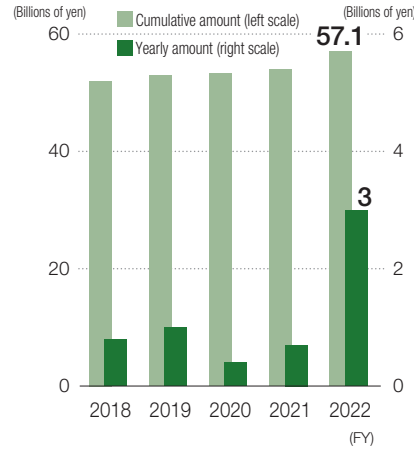

By-product recycling rate

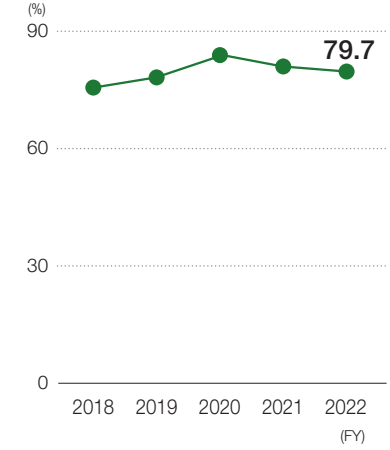

Amount of capital invested in environmental protection* * Cumulative total from 1977

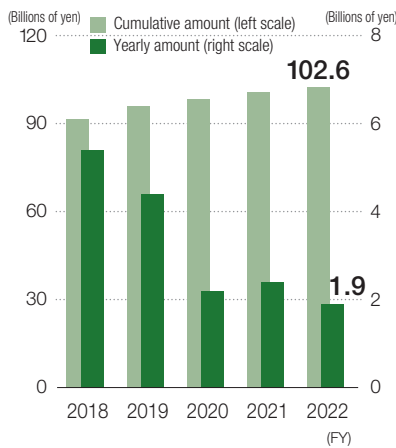

R&D expenses for environmental products

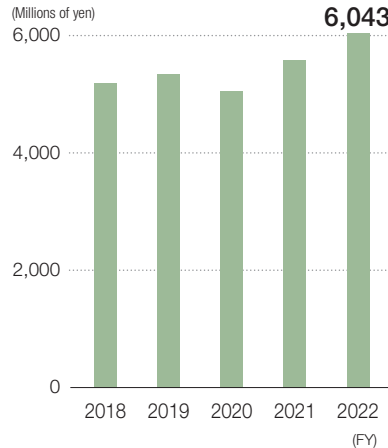

Number of employees

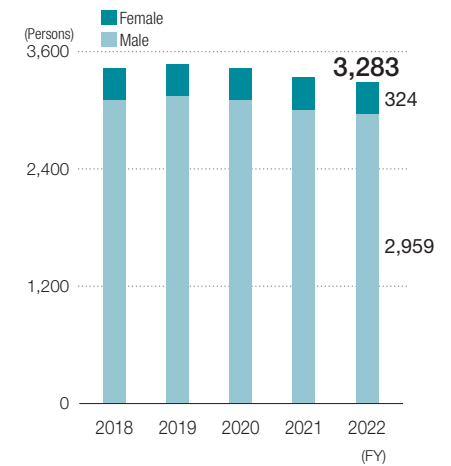

Ratio of women in management

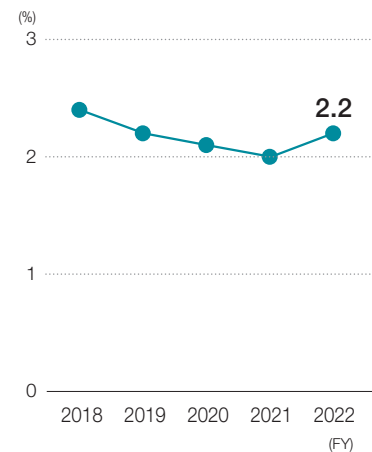

Ratio of lost-time work injuries

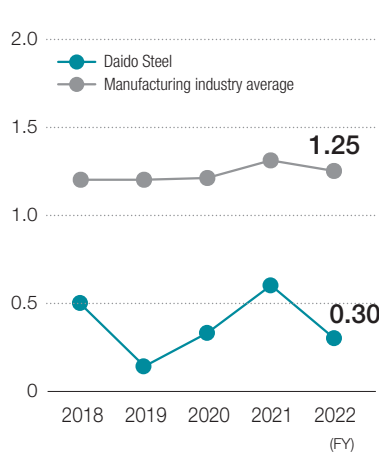

Major quality accident index*

* Index taking the actual results from 2006 as "1"

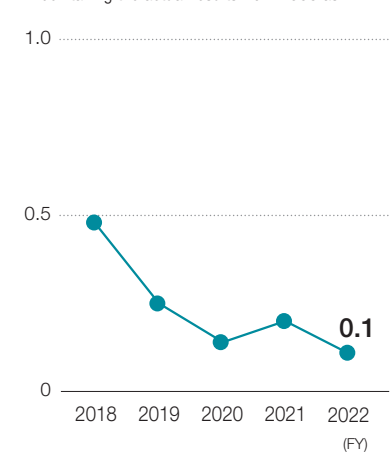

* Details about environmental data are disclosed on our website.

Sustainability Management

Using our unique DNA to maintain sustainability for the next 100 years

Representative Executive Director,
Executive Vice President

Tsukasa Nishimura



We live in a time when it is impossible to anticipate sustainable development for companies with traditional profit-oriented management. Sustainability management is crucial for companies to continue to develop sustainably through value creation. The Company has a long history and celebrated its 107th anniversary in 2023. We must continue to exist for the next 100 years as a business that adapts to the era and contributes to society.

It is essential to continue to embrace the challenge of a new era while appreciating the DNA from the past. Daido Steel's roots lie in an area of outstanding natural beauty, the Kiso River system. Momosuke Fukuzawa, the Company's founder, had developed hydroelectric power generation to supply the Chubu and Kansai regions, but since nighttime electricity demand was lower than daytime demand, he came up with an unconventional solution to effectively utilize the surplus nighttime electricity and built Japan's first electric arc furnace steelmaking plant. The concepts of the effective use of energy and ultimate recycling of electric arc furnace steelmaking—a process that melts down surplus scrap and produces new steel—are closely tied to modern times, and

we have been pursuing them for over a century.

It is not an exaggeration to say that the Company's history is a history of mergers since our founding in 1916. After repeated mergers, the current Daido Steel was born in 1976 through the merger of Japan Special Steel, Tokushu Seiko, and Daido Steel, and has since developed into one of the world's largest dedicated specialty steel manufacturers. Because of our history of mergers, we have diversity, which is the ability to accept different cultures. Additionally, we have been able to preserve our independence because we don't have a parent company, an atypical management style for a specialty steel manufacturer. Diversity and independence are a part of our founding mindset, which we have appreciated even in the face of challenging environmental changes and could be said to be two of our strengths. Diversity and independence are in alignment with the corporate governance standards that are being imposed on companies, and they also reflect our unique mindset, which will be crucial as we work toward sustainability management in the future.

Promotional base and priority themes for sustainability management

Over the past year, the Company has made a big turn of the wheel toward sustainability management. In April 2022, we established a Sustainability Committee chaired by the President, and a full-time outside director who is an Audit & Supervisory Committee member also serves as a committee member, and discussions include an outside perspective. Additionally, in January 2023, we established the ESG Management Department as the secretariat of the Sustainability Committee. We have established a Sustainability Promotion Section and a Global Environment Affair Section within the ESG Management Department to strongly promote ESG management.

The Sustainability Committee originally had four meetings per year planned, but after lengthy discussions about issues that needed to be fixed, there were ten meetings in fiscal 2022. The content included not just a general discussion of sustainability management but also more specific topics like "CO₂ reduction activities," "water security," "respect for human rights initiatives," "integrated report and corporate governance report," "anti-corruption activities," and "human capital management." Among these, we have focused on three important themes: (1) climate change, (2) human capital management, and (3) corporate governance. The main content is explained below.

Three paths to carbon neutrality

First, regarding our initiatives to address climate change, in order to reduce CO₂ emissions, we first introduced the "Daido Carbon Neutral Challenge 2030" in 2021. This initiative aims to cut CO₂ emissions by 50% by 2030 compared to 2013, and our target is to become carbon neutral by 2050. We held an ESG briefing titled "Value to Green Society 2030" in December 2022 to inform investors and the media on our initiatives to combat global warming and to deepen their knowledge. In the future, we will report not only on the environment but also on social and governance themes.

We have stated that we will support the following three carbon neutral (CN) strategies as part of our efforts to address global warming.



ESG briefing in December 2022

CN process	Promote reduction of CO ₂ by integrating energy-saving technologies into own manufacturing processes
CN products	Developing various innovative products that support mobility innovation and contributing to the realization of a green society
CN solutions	Support customers in reducing CO ₂ emissions with products that incorporate innovative energy-saving technology based on a combination of engineering design and in-house operational know-how

For specific initiatives regarding the three themes in the table above, please see "Initiatives to Address Climate Change" on P.67-70.

In addition, as part of our participation in environmental initiatives, we endorsed the TCFD in November 2021, understood the risks and opportunities that climate change brings to the Company, and their impacts, evaluated the resilience of Daido Steel's medium- to long-term strategy and the need for further measures. After formulating specific measures, we disclosed the information in 2022. In addition, we took part in the Ministry of the Environment's "30by30 Alliance for Biodiversity" in September 2022, and endorsed the basic concept of the Ministry of Economy, Trade and Industry's "GX League" in March 2022, and announced our participation in April 2023. Also, we participated in the Hydrogen Utilization Study Group in Chubu as part of a project to build a supply chain to realize a hydrogen society.

Blast furnace manufacturers have begun offering green steel, which has lately gained attention as a CO₂-free steel material, utilizing the mass balance approach; however, for electric furnace steel, the official definition of CO₂ reduction level has not yet been clarified. In order to sell green steel, it is essential to fully comprehend the CO₂ emissions per ton of each product and calculate the amount of CO₂ reduced based on certification from a third-party organization. We are actively working toward obtaining this certification. After receiving certification, we will keep promoting the usage of electric furnace steel, which produces less CO₂, and renewable electricity, as well as our green steel brand.

Sustainability Management

Human capital management that creates job satisfaction

The following five Conduct Guidelines for human resources who will realize our management philosophy as part of our initiative in human capital management.

- Aim High
- Sincere Action
- Personal Growth
- Team Strengths
- Open to Challenges

We offer a variety of human resource development options based on these guidelines, including personnel who will be in charge of future management, professional personnel, and production site operators. Additionally, it's crucial to capitalize on diversity and give women, foreign employees, and mid-career employees the chance to participate actively and advance their careers in order to make up for the staffing shortage brought on by a potential decrease in the working population. We launched a diversity promotion project in 2014 within the Personnel Department to encourage the creativity of diverse human resources. We are working to create a good environment in which we aim to double the number of female managers from the present 15 to 30 by 2030, and further increase the number of foreign managers and mid-career managers from the present 2 to 68, respectively.

On the other hand, compared to before, there are now more retirees at our company, mostly from the younger generation. It takes ten years to acquire the knowledge and skills necessary to produce specialty steel products, so retiring with only a few years of experience would be a big loss for the Company. Work must be made more comfortable and conducive to productivity in order to halt this. To make work more comfortable and conducive to productivity, it is important to increase employee engagement and realize well-being, which entails having them understand and empathize with the Company's goals as well as enhancing individual rights and working conditions to maintain a healthy state of mind and body.

Specifically, to earn our employees' understanding and empathy, we need to explain our company's management philosophy, conduct guidelines, medium- to long-term strategies, and direction to them in a more easily understandable manner. The next step is for each employee to consider the purpose of their position and align their own objectives with those of the Company. We are making work easier by raising the rate at which men take childcare leave, raising the total number of annual leave days taken by all employees, and enhancing the working environment for women, all of which are urgent issues related to the empowerment of women. In our opinion, it's important to create job satisfaction. With the aim of "achieving more autonomous self-growth and finding attractive jobs," we are building a specific system that will enable working women to play an even more active role.

To strengthen governance

Regarding corporate governance initiatives, our company transitioned to a company with an Audit & Supervisory Committee in June 2022 with the purpose of strengthening the governance system. Along with this transition, we have delegated a part of the resolutions of the Board of Directors to the President to speed up decision-making and focus the content deliberation in



the Board of Directors, and have increased the ratio of outside directors on the Board of Directors to over one-third. Additionally, we have established a Nominating and Remuneration Committee, which serves as an advisory organ to the Board of Directors, with four of the six directors being outside directors, to enhance transparency and fairness.

Regarding the development status of the internal control system, the Corporate Risk Management Department (CRM Department) continuously monitors and audits the internal control system of the whole Daido Steel Group and promptly reports to management with the findings. Additionally, a CRM Committee that holds regular meetings has been established as a decision-making body for the creation and implementation of internal controls in accordance with risk management, the Companies Act, and the Financial Instruments and Exchange Act. The chairman of this Committee is the President, and the Committee meets twice every six months, and whenever necessary. In fiscal 2022, the Committee met a total of eight times, and submitted matters to the Board of Directors as necessary. Additionally, the Group CRM study session aims to lower risks with domestic and international Group companies by exchanging information on risk management.

The corporate governance code was revised in June 2021, further increasing demands for the transparency and effectiveness of corporate governance. Regarding the parent-subsidary listing issue, the Company has two listed subsidiaries: Nippon Seisen Co., Ltd., a stainless steel wire manufacturer, and FUJI OOZX Inc., an automotive valve manufacturer. The reasons for the listing of both companies are to expand business transactions based on name recognition and trustworthiness, advantage in capital procurement, and securing excellent human resources. By combining the benefits of listing with Group synergies, it greatly contributes to maximizing the corporate value of the entire Daido Steel Group. Additionally, both companies are strengthening their governance systems and working to secure the interests of general minority shareholders. We are aware that there are concerns about the purpose of the parent-subsidary listing from the perspective of protecting the interests of investors and other minority shareholders and we will continue to consider medium- to long-term options while taking changes in the business environment into account.

Regarding cross-shareholdings, every year, Daido Steel reviews the purpose and appropriateness of individual cross-shareholdings in the Board of Directors. Many of the cross-shareholdings we hold are stocks of companies that are our customers, and we have continued to hold stocks that we think would significantly increase product sales while reducing the

number of stocks we think will only slightly increase sales. In the future, as outlined in our Medium-Term Management Plan, we will reduce the amount of cross-shareholdings, including deemed shareholdings, to 20% or less of net assets by March 2024, and aim to reduce it to around 10% in the future. In addition, we plan to use the proceeds from the sale for carbon neutral investments and strategic investments, but will also consider shareholder returns.



What is sustainability management?

At the Company, sustainability management entails putting a lot of effort into risk management to reduce harm to corporate value and making the most of opportunities, which are the opposite of risk and may be used to improve corporate value and generate profits.

It is natural for a company to return profits to shareholders in line with profits, and our company has also increased its dividend payout ratio. At the same time, it is very important for us to maintain profitability while adapting to the rapidly changing corporate environment. To realize our goal for 2030, we must continue making proactive strategic investments and reform the profit structure of existing businesses. Retain-and-Reinvestment is the foundation of corporate growth, and we will strive to improve corporate value by firmly fulfilling our management responsibilities and accountability.

The complexity of sustainability challenges is rising, making them challenging to handle from an internal perspective alone. We take part in multiple sustainability initiatives because we aim to expand our knowledge in specific areas and collaborate with others to quickly improve the Company's sustainability management. In July 2023, we signed the United Nations Global Compact. This is because of the fact that addressing "human rights," "labor," "environment," and "anti-corruption" in a global setting is necessary if we want to continue growing our overseas business. We will keep proactively taking part in initiatives and working toward sustainability management.



Sustainability Basic Policy and Materiality

Sustainability basic policy

Since being established in 1916, Daido Steel has responded to the demands of society with manufacturing based on specialty steel, and has contributed to its development. As the world faces an era of great change, our goal is to be a corporate group that will continue to be recognized and sought after by future society, and we aim for a 2030 vision to “Pursue high-performance specialty steel and contribute to ‘realization of a green society.’”

The Company prioritizes preservation of the global environment through climate change measures and the supply of high-performance products as material issues, and we will work to

contribute to sustainability through manufacturing. As a responsible company, we will also put into practice our responsibilities and contributions to society, such as respect for human rights, strengthening our human capital, and coexistence with local communities. We will actively pursue further initiatives to strengthen governance as the foundation for putting materiality into practice. Our management philosophy of “pursuing the potential of materials to support our future” has been instilled in these approaches to sustainability and is put into practice every day as our corporate activities.

SDGs initiatives

Sustainable Development Goals (SDGs) were adopted by the United Nations in September 2015 as a common language for achieving a desired vision of the world by resolving social issues under the slogan “Leave No One behind.”

The Company will provide specialty steel to support a more prosperous future society through manufacturing that leverages the technological capabilities it has cultivated hitherto based on its management philosophy, its product development capabilities, and its capacity for innovation, and will work to bring about the world aimed for in the SDGs.



Organization of promoting sustainability

In addition to establishing a CSR Committee chaired by the President in fiscal 2007, and strengthening CSR activities to fulfill its corporate social responsibilities, the Company has addressed a variety of issues.

In recent years, it has become even more important for management to achieve both a sustainable society by solving social issues and the sustainable enhancement of corporate value. Based on this trend, in April 2022 the Company established a Sustainability Committee as an advisory body to the Board of Directors.

We also established the ESG Management Department as a specialized department responsible for rolling out various

company-wide measures.

The Sustainability Committee conducts planning and drafting of proposals and provides opinions with regard to basic management policies, as well as promotional activities and strategies related to sustainability. Important matters are decided after being reported to or put on the agenda of the Board of Directors. The Committee met ten times in fiscal 2022.

The Company has positioned sustainability at the core of management, and will take a forceful approach to promoting the various measures related to materiality, centered on addressing climate change.

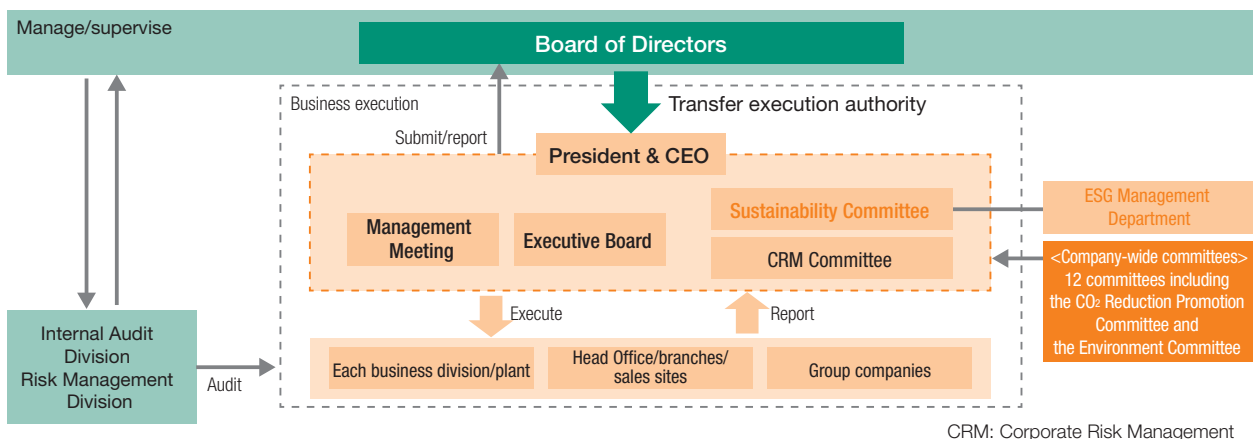

CRM: Corporate Risk Management

Materiality

The materiality formulated in fiscal 2020 is reviewed every year.

After re-evaluating "risks and opportunities" from a management and a stakeholder perspective, we have newly identified respect for human rights, supply chain management, and strengthening governance as additional material issues from

2021 onward. At the same time, preservation of the global environment has been reorganized by dividing it into the categories of business activities and product supply. In fiscal 2022, stakeholder communication was added.

Materiality for fiscal 2023 is as follows.

1. Preservation of the global environment (business activities)	Initiatives to address climate change	▶ P.67-70
	Transition to a circular economy	▶ P.71-72
2. Preservation of the global environment (product supply)	Technological innovation for energy transition	▶ P.73
	Improvements in energy efficiency	▶ P.74
	Effective utilization of natural resources	▶ P.74
3. Responsibilities and contributions to society	Respect for human rights	▶ P.75-76
	Elimination of occupational accidents	▶ P.77-78
	Promotion of health and productivity management	▶ P.79-80
	Promotion of diversity	▶ P.81-83
	Work style reforms	▶ P.84
	Social contribution initiatives	▶ P.85-86
	Supply chain management	▶ P.87-88
4. Strengthening governance	Strengthening of corporate governance	▶ P.93-98
	Risk management and compliance	▶ P.101-106
	Stable supply of high-quality products	▶ P.107-108
	Stakeholder communication*	▶ P.109-110

* Reviewed in fiscal 2022

Process of identifying material issues

[1] Identification of social issues

Identify 95 social issues by comparing the SDG targets to the global risks in the Global Risk Report 2019, excluding duplicated issues, and add issues attracting a high level of social concern

[2] Evaluation from business perspective

Evaluate the importance of the social issues in terms of risks and opportunities for the business of the Company, from short-term, medium-term, and long-term standpoints

[3] Evaluation from stakeholder perspective

Evaluate the issues considered important by stakeholders in each area of business, and the relationship to the items assessed by ESG evaluation institutions

[4] Preparation and identification of materiality matrix

Integrate business and stakeholder evaluations to prepare a materiality matrix. Materiality for Daido Steel is identified after being discussed twice by the Sustainability Committee

2023 Medium-Term Management Plan Progress

We have reformed our portfolio with a focus on growth products while achieving operating income levels in excess of our medium-term targets by taking action to secure appropriate margins in response to rising costs.

Going forward, we will continue to stabilize management foundations while pursuing aggressive growth strategies and closely monitoring environmental changes over the medium to long term.

Director, Managing Executive Officer

Tatsushi Iwata



In June 2021, we launched the 2023 Medium-Term Management Plan, a three-year plan with fiscal 2023 (ending March 2024) as its final year. From a medium- to long-term perspective, efforts to curb global warming are expected to gain momentum on a worldwide scale, and progress is expected in the transformation of social structures with the aim of reducing CO₂ emissions. Electrification is accelerating in the automobile industry, and internal combustion engine vehicles are expected to peak out in the 2020s. In conjunction with the shift from fossil fuels to clean energy, hydrogen and other new energy sources are attracting greater attention. In addition, the acceleration of the digital revolution is expected to lead to sustained growth in the semiconductor industry, which supports telecommunications and other aspects of digitalization.

We believe that it will be extremely important to increase our earning power in order to achieve corporate growth in preparation for these changes in the business environment. Accordingly, we have made systematic and strategic investments and have reformed our business portfolio. (Refer to Changes in Operating Income by Segment on the right page.) In the second year of the current medium-term management plan, we have achieved

success with prior strategic investments, enhanced the upward elasticity of production capacity, and supplied products in a timely manner in response to new demand. In conjunction with this, we have also made efforts to correct sales prices in light of the soaring cost of energy and changes in foreign exchange rates. To give one example, since we are in the electric furnace business, which uses electric power to melt iron, we introduced an energy surcharge scheme for customers with major transactions in which the sales and delivery destinations are already determined when the steel products are made. As a result of these efforts, we were able to exceed the operating income target under the medium-term management plan one year early. I believe that we were able to implement price corrections because customers recognize that our products are high market value products with limited alternatives. In the future, it is essential that we increase our competitiveness even further and demonstrate our presence by shifting to high-performance products and taking other actions.

In fiscal 2023, the final year of the medium-term management plan, we will continue our efforts to achieve key KPI targets by carrying out the fundamental policies set forth in the plan.

2023 Medium-Term Management Plan Awareness of the business environment and fundamental policies

Significant changes in the external environment	Effects on and responses by the Daido Steel Group	Fundamental policies
<ul style="list-style-type: none"> ● Acceleration of initiatives for achieving a green society and tighter regulation of greenhouse gas emissions 	<ul style="list-style-type: none"> ● Reducing CO₂ to achieve a green society is unavoidable 	<p>2030 Vision Pursue high-performance specialty steel and contribute to “realizing a green society”</p> <p>Fundamental Policies of the 2023 Medium-Term Management Plan</p> <ol style="list-style-type: none"> 1. Expand businesses in fast-growing fields 2. Strengthen management’ agility 3. Expand further overseas business 4. Promote ESG management
<ul style="list-style-type: none"> ● Rapid advancement of the electrification of mobility 	<ul style="list-style-type: none"> ● Capture and expand demand for high-performance products in response to decreasing demand for structural specialty steels 	
<ul style="list-style-type: none"> ● Acceleration of the digitalization of lifestyles and work 	<ul style="list-style-type: none"> ● Appropriate responses to long-term growth in the semiconductor manufacturing equipment market as a result of the spread of fifth-generation mobile communication systems (5G) 	
<ul style="list-style-type: none"> ● Soaring prices for energy and raw materials 	<ul style="list-style-type: none"> ● Reinforce price competitiveness and secure appropriate roll margins 	
<ul style="list-style-type: none"> ● Decline in working population in Japan due to a low birthrate and aging population and rising importance of promoting active participation by women 	<ul style="list-style-type: none"> ● Recruiting and developing human resources and raising productivity are crucial issues 	

Changes in Operating Income by Segment (Consolidated)

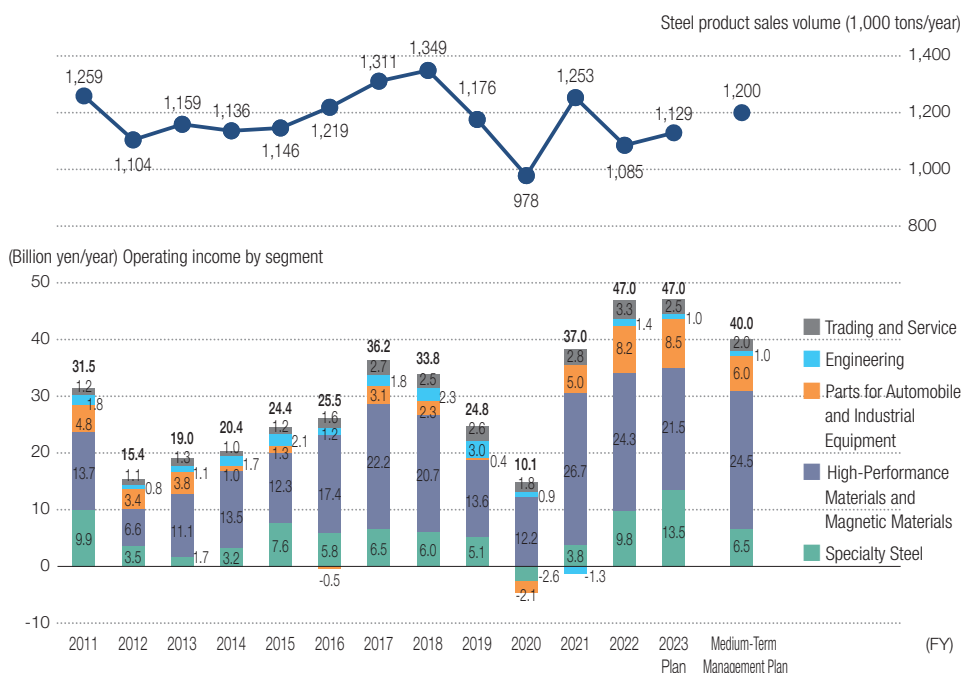

Medium- to Long-Term Outlook

- Engineering**
 - Expand energy-saving products to achieve carbon neutrality
- Parts for Automobile and Industrial Equipment**
 - Capture increasing demand for free forging products over the medium- to long-term
 - Maintain products with high market shares
 - Increase in orders due to the expansion of certification acquisition
- High-Performance Materials and Magnetic Materials**
 - Expansion of high-performance stainless steel including stainless steel for semiconductor manufacturing equipment
 - Increased demand for magnets in conjunction with the expansion of BEVs and HEVs
- Specialty Steel**
 - Lower demand for steel for internal combustion engines
 - Increased demand for steel used in e-Axles
 - Reduce costs and secure appropriate roll margins

Large-scale investment in Shibukawa Plant (free forging products, superalloys, and high-performance stainless steels)

- 25t VIM furnace (November 2016)
- Two remelting VAR furnaces (July 2019)
- One remelting VAR furnace (July 2023)

150t furnace at Chita Plant (November 2013)

- Cost reductions (structural steel)

Chita Plant No. 2 CC streamlining (August 2019)

- Cost reduction (bearings, stainless steels)

Hoshizaki Plant, Chita Second Plant (high-performance stainless steels, titanium products)

- Augmentation of wire rod secondary processing (heat treatment furnaces and other facilities) (August 2019)
- Augmentation of processing capacity (October 2020, January 2021)
- Expansion of heat treatment furnace (April 2021)
- Augmentation of processing capacity (April 2023)
- Two remelting VAR furnaces (scheduled for end of fiscal 2024)
- One remelting VAR furnace for titanium (scheduled for end of fiscal 2024)

Status of progress of key KPI

Sales volumes have declined, particularly of specialty steels, but we have reformed our portfolio by expanding high-profit products such as free forging products and semiconductor manufacturing equipment, and we have made efforts to secure appropriate margins in response to rising energy costs. As a result, both operating income and return on equity (ROE) exceeded the target values under the medium-term management plan.

From a financial perspective, however, prices for raw materials have increased substantially (compared to the assumptions of the medium-term management plan), and operating capital has increased, including an increase in inventory assets.

In response to these developments, we have secured the necessary capital in line with the increase in operating capital through interest-bearing debt. As a result, the D/E ratio is expected to be 0.65 as of March 31, 2024 and will not reach the target of 0.5 set in the medium-term management plan.

We have set a target of achieving carbon neutrality by 2050. Going forward, we will make strategic investments in growth areas, and we are aware that since substantial funds for capital investment will be necessary to achieve carbon neutrality, we need to make effective investments while ensuring the soundness of the Company's financial foundations.

	2023 Medium-Term Management Plan Targets	FY2021 Results	FY2022 Results	FY2023 Plan	Status of Progress
Operating income	At least ¥40.0 billion	¥37.0 billion	¥47.0 billion	¥47.0 billion	Level in excess of the FY2022 target value
Return on equity (ROE)	8.0%	8.5%	10.4%	8.4%	Maintain at least 8% starting in the first year
D/E ratio	0.5	0.69	0.64	0.65	Target value not reached due to increase in interest-bearing debt
Investment; three-year cumulative approval basis	¥85.0 billion	-	-	¥90.0 billion	Encourage strategic investment in growth areas
Sales volume of steel products (non-consolidated)	1,200,000 tons	1,253,000 tons	1,085,000 tons	1,129,000 tons	Medium-term management plan value not achieved due to decline in automobile-related demand

2023 Medium-Term Management Plan Progress

Progress of the 2023 Medium-Term Management Plan (four basic policies)

1 Expand businesses in fast-growing fields

Progress: Good

Conduct R&D to achieve carbon neutrality

We are introducing test equipment that can perform material evaluations tailored to new use environments so that we can develop new materials in fields expected to undergo substantial growth in conjunction with revolutionary changes in mobility, energy, and other areas.

Large-scale strategic investment in growth areas

With the aim of reforming our portfolio even further, we are making active capital investments in future growth areas such as high-performance steels, superalloys, and titanium products.

Capital investment ▶ P.41

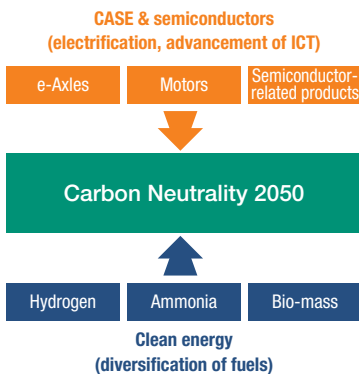

Growth areas	Applications	Materials to develop and expand sales	Testing equipment
CASE & semiconductors 	e-Axle gear reducers	Gear steel	High peripheral speed testing equipment: Operational in 2022
	Motors	Magnets and soft magnetic materials	Motor testing equipment: Under operation
	Semiconductor manufacturing equipment	Stainless steels, superalloys	Gas erosion testing equipment: Implemented in 2023
Clean energy 	Hydrogen/ammonia-related manufacturing	Stainless steels, superalloys	Hydrogen embrittlement testing equipment: Implemented in 2022
	Bio-mass-related manufacturing	Stainless steels, superalloys	Corrosion testing equipment: Under operation

2 Strengthen management' agility

Progress: Excellent

Production allocation

In parallel with reformation of our portfolio by expanding businesses in fast-growing fields, on the production side, we are implementing various measures that will contribute to lowering the break-even point including consolidation of production among plants, raising productivity, and improving yields, and we are increasing production efficiency and reducing costs.

The Company's main production sites are the Chita Plant, Hoshizaki Plant, and Shibukawa Plant. Under the 2023 Medium-Term Management Plan, we are working to maximize production efficiency through specialization of the functions of each plant. The Chita Plant has higher production efficiency and lower costs than the other plants, and consequently, we are shifting production of high-volume stainless steels from the Hoshizaki Plant to the Chita Plant. With this shift, the Hoshizaki Plant will

specialize in difficult-to-process materials. In addition, we introduced two vacuum arc remelting (VAR) furnaces for high-performance stainless steels at the Chita Second Plant so that the Shibukawa Plant can specialize as a superalloy melting mother plant with a focus on the manufacture of free forging products such as aircraft parts. This will make it possible to supply base materials from a plant close to the Hoshizaki Plant, which is the shipment plant for high-performance stainless steels, leading to shorter lead times and a decrease in inventory assets.

The specialization of functions is not something that can be completed in just a few years, and we believe that it will be an ongoing process that extends into the next medium-term management plan and the one after that as well. In addition, we will make full use of the Chita Second Plant to actively develop and commercialize products in new growth areas.

Consolidation of production at the Chita Plant

- Consolidate production to the Chita Plant, which has high productivity and high yields due to progress in the development of melting and rolling technologies, thereby reducing CO₂
- Consolidated production of 2,500 t/month in melting processes and 1,500 t/month in rolling processes and will consolidate production further at the Chita Plant

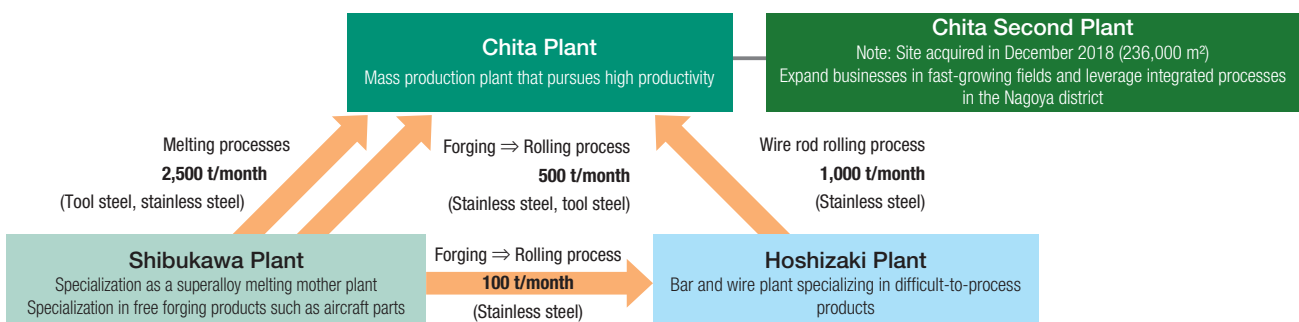

Selection and consolidation of business

We are scrutinizing low-profit businesses and concentrating management resources to strengthen management' agility.

The 2023 Medium-Term Management Plan calls for rebuilding the die forging business, and we have decided to withdraw from die forging products and housing products, which have generated low profits for many years. Going forward, the die forging business will specialize in high-speed, high-precision forged products.

In addition, the precision casting business also generates low profits, so we have reduced acceptance of orders for turbo housing products and liquidated a Chinese subsidiary engaged in the turbo parts processing business. In conjunction with the reduction of orders, we will consolidate plants in Japan, and we will investigate using the plant sites as auxiliary manufacturing plants for magnets, orders for which are expected to increase in the future. In the future, we will assess business in a timely manner and concentrate management resources.

	Concentration of management resources	Assessment of business
Tool steel business	<ul style="list-style-type: none"> Established a tool steel plant in Vietnam (May 2023) Seek to expand business in India 	<ul style="list-style-type: none"> Withdraw from the mold business in Mexico (May 2021)
Die forging business	<ul style="list-style-type: none"> Focus on high-speed, high-precision forged products Acquisition of mold business in the U.S. (March 2023) 	<ul style="list-style-type: none"> Withdrawal from die forging products and housing products (phased withdrawal starting in March 2023)
Precision casting business (turbo)	<ul style="list-style-type: none"> Plant consolidation in conjunction with the reduction of orders 	<ul style="list-style-type: none"> Reduction of orders accepted for turbo housing products (March 2020) and liquidation of subsidiary in China (October 2020)
Trading and service business	<ul style="list-style-type: none"> Acquisition of trading business in China from TimkenSteel (July 2021) 	<ul style="list-style-type: none"> Suspension of operations of Kisokomakogen Uyama Country Club and Kisokomakogen Kanko Hotel (December 2020)

3 Expand further overseas business

Progress: Improvement needed

Reinforcement of overseas supply chain

The Daido Steel Group comprises 71 companies, of which 38 are overseas consolidated subsidiaries, and of those, 28 are located in Asia (10 in China, 16 in ASEAN, and two in India). Under the 2023 Medium-Term Management Plan, we seek to increase overseas sales of high-performance stainless steels, superalloys, and tool steels, with a focus on these Asia markets. To expand our overseas business, we are implementing a

strategy of reinforcing supply chains according to the business environment and conditions of these markets in each region. Due to travel restrictions imposed in response to the COVID-19 pandemic and other factors, however, various measures have not progressed as quickly as anticipated. We recognize that the progress of specific measures in the Indian market, where growth is particularly expected, is an urgent issue.

China	<ul style="list-style-type: none"> Development of foundations that will lead to higher sales of Special Bar Quality (SBQ) products as well as increased sales capabilities for superalloys and specialty steels in China centered on Daido Steel Materials Technology Shanghai Co., Ltd., a subsidiary acquired from U.S.-based TimkenSteel in August 2021
ASEAN	<ul style="list-style-type: none"> Established new bar and wire secondary processing site (production started in January 2022) In Thailand, we established Daido Shimomura Steel Manufacturing (Thailand), reinforcing local supply chains for high-performance materials including stainless steels
India	<ul style="list-style-type: none"> In the Indian market, where growth is expected, we are investigating the possibility of expanding our collaboration with Sunflag Iron and Steel Co. Ltd. and seek to expand the scale of the tool steel business
United States	<ul style="list-style-type: none"> Acquired plant facilities for the hot forging mold manufacturing business and established Lexington Technologies Company in March 2023. By generating synergies with Ohio Star Forge, our manufacturing base in North America, we seek to increase profits and strengthen the competitiveness of parts for the automobile and energy businesses in North American markets

4 Progress of ESG management

Progress: Good

To further implement ESG management with the aim of enhancing sustainable corporate value, the CSR Committee was renamed the Sustainability Committee and its functions were further developed in April 2022. The ESG Management

Department was established in January 2023, and we are reinforcing various measures to protect the global environment (E), fulfill our responsibilities and contribute to society (S), and reinforce governance (G)

E	1 Preservation of the global environment (business activities)	<ul style="list-style-type: none"> Promote reduction in CO₂ emissions (Target: Reduce by 50% by 2023 and achieve carbon neutrality by 2050) Participation in the GX League (April 2023)
	2 Preservation of the global environment (product supply)	<ul style="list-style-type: none"> Supply of products in response to innovations in mobility: Magnets and soft magnetic materials (powders and steel strips) Development of technologies that contribute to the effective utilization of natural resources: Ultra-high-temperature carbonizing furnace
S	3 Responsibilities and contributions to society	<ul style="list-style-type: none"> Respect for human rights → Publication of Daido Steel Group Human Rights Policy (February 2023) Promotion of human capital management Measures to address biodiversity and contributions to local communities
G	4 Strengthening governance	<ul style="list-style-type: none"> Stakeholder communication → Emphasis on dialogue with investors and shareholders, reinforcement of IR and SR activities Transitioned to a company with an Audit & Supervisory Committee (June 2022) Introduction of the stock compensation plan for directors (June 2023)

R&D and Intellectual Property Strategies

“With innovation through close internal and external collaboration, Daido Steel is able to generate products that impart special functions that exceed expectations and support the foundations of society”



Managing Executive Officer

Ikuko Sugie

R&D policy

Up to now, Daido Steel has established numerous alloy designing and manufacturing technologies that achieve compatibility between maximum extraction of the performance of specialty steel and practical manufacturing costs. However, the materials newly required by CASE, the shift to electric vehicles, a hydrogen society, and so on due to the transformation to a carbon-neutral society means that we must broaden our horizons to include not only the insights accumulated with existing steel materials alone, but also combinations with industries and materials, such as electricity and chemicals, with which we have barely interacted before. We also need new value and

performance that are not just an extension of what we've been doing until now.

To Daido Steel, we believe that innovation means plunging without hesitation into unfamiliar areas where we have few results, raising our antennae to pick up expected future needs, and contributing to the realization of a more abundant and sustainable society. However, the new market that we will challenge should not be an enclave that is completely unrelated to us, even though it is a growing market sector, but rather an area where we can take advantage of the core technologies and intellectual property we have built up over the years.

Management

Management of R&D

The Corporate Research & Development Center that is the core of R&D in the overall Daido Steel Group has slightly over 300 personnel and is generating organic synergies by collaborating closely with internal business divisions, Group companies, and external research institutions.

The Corporate Research & Development Center decides on resources invested until business formation based on the type and importance of technology development themes. For

example, we will maximize investment of internal development resources to realize important development themes that have a significant impact on the management of the Company. However, for explorative themes taken on with a medium-to-long-term perspective, we are proactively utilizing external partners and balancing overall resources, such as investing internal resources flexibly while looking closely at feasibility.

According to the timeline, the differences in management will be as follows.

Short-term	<ul style="list-style-type: none"> Responding to customers' development schedule with a sense of urgency Managing progress through close communication not only within the Corporate Research & Development Center alone but also with business divisions (sales division and manufacturing division)
Medium-term	<ul style="list-style-type: none"> Monitoring the orientation and market trends of customers' product development while collaborating with business divisions in the same manner as for short-term themes Reporting new developments in key elemental technology according to their importance and budget scale, and supervision by research executives to management
Long-term	<ul style="list-style-type: none"> Steadily transferring the technical skills for our various core technologies (alloy designing, materials analysis, process improvement, simulation analysis) to the next generation Setting a vision and targets, because there may be great unknown potential in tackling themes that are conscious of new products in macro future growth markets. For themes that seem likely to thrive, moving up to the next phase in marketing, in collaboration with business divisions, so that it can be proposed as a new product Providing stimulation based on discussions of cutting-edge technology focused on academic activities and enhancing the ability to invent and create by studying published research results

Investment in R&D resources is shifting every year to projects aimed at "realizing a green society." Below are the trends in R&D expenses for existing areas and new areas, but the ratio of development expenses in new areas, such as realizing a green society, is also increasing.

Trends in R&D expenses for existing and new areas

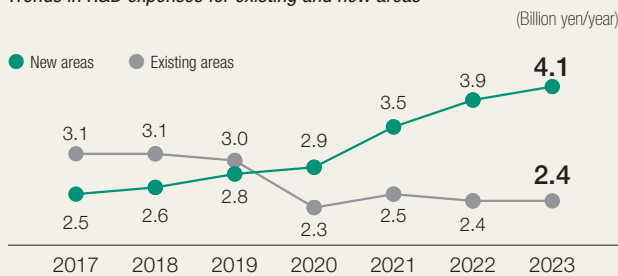

Meanwhile, in May 2022 we also carried out corporate restructuring for overall streamlining, setting up the new Process Technology Research Section that integrates the melting and

casting technology and process molding laboratories, shutting down the Solution Support Section, and reassigning the human resources.

Management of intellectual property

We are actively filing applications for advanced technologies acquired as a result of R&D. We are further deepening collaborations with business divisions, and, in conformity with our product sales expansion strategy, we are aware of the establishment of patent rights and the differentiation from our competitors' technologies. We strive to contribute to profits through appropriate management of patents.

Because R&D is an activity that gives rise to the added value of new ideas, it is closely tied to intellectual property. In the first stage of drawing up an R&D theme, we confirm novelty from a patent-filing perspective, including in the sense of checking the necessity of proceeding, and whether it is in competition with an existing patent. Furthermore, every six months we nominate in advance the projects that will be candidates for patent filing and manage them so that we can steadily move forward with applications and the establishment of rights along with the progress of the research themes.

Old and new organizational chart of the Corporate Research & Development Center

● Previous research system

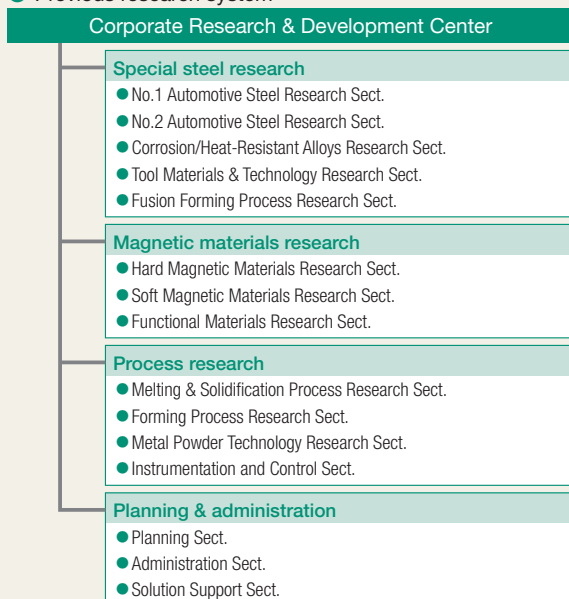

● Current research system



R&D and Intellectual Property Strategies

Initiatives on priority issues

The initiatives on the three priority issues are described below.

1. Technological trends and portfolio transformation to realize a green society

In order to address the change to a carbon-neutral society, we have adopted a strategy of shifting to electric vehicles (motors, batteries, inverters, gears, etc.), developing new materials used in the materials that contribute to a hydrogen society, improving the performance of existing materials, and distributing resources (personnel and budget) to develop manufacturing processes that support these based on prioritization. The following are specific examples, and about 80% of total resources will be invested.

- Motors: Hot worked magnets, PLP magnets, development of motor performance evaluation technology
- Batteries: Anode materials for lithium-ion batteries
- Inverters: Materials related to semiconductor manufacturing equipment (CLEANSTAR, etc.), development of super clean steel manufacturing technology
- Gears: High-strength gears for e-Axle (structural steel)
- Hydrogen: Materials with hydrogen embrittlement resistance, development of new evaluation technology

2. Co-creation with external parties

In the past, the Company held firm to the doctrine of self-sufficiency. However, as we deepen relationships with customers in industries where we have not previously had any business dealings, we have increasingly sensed the danger in our inability to respond promptly to global trends with only existing platforms. As such, we have formed proactive partnerships with external parties, including universities, research institutions, and other companies, and are accelerating efforts to acquire new technology through open innovation.

Co-creation with external parties has had an enormous effect and has been useful in helping us to quickly understand areas that are unfamiliar to us (chemicals, electricity) at an early stage and in speeding up R&D. Meanwhile, it also contributes to increasingly sophisticated levels of material and process development by enabling us to approach even our own existing technology (metallic materials) with an even higher degree of specialization. This creates a system that meets market expectations for the development of ever-more advanced materials and products. Partnerships with external parties, such as the establishment of endowed university courses and joint research with overseas technology research institutions, have grown to a current total of 45 (11 more than the previous year).

Soft magnetic powder for reactors used in the latest hybrid systems

In February 2023, the part (reactor) that increases the voltage of batteries for hybrid automobiles, which we jointly developed with the Toyota Motor Corporation, Toyota Central R&D Labs., Inc., DENSO Corporation, and Fine Sinter Co., Ltd., was adopted in the latest hybrid systems.

The soft magnetic powder that has been used here is a material designed by the Toyota Motor Corporation and Toyota Central R&D Labs. By applying our own atomization technology and powder processing technology and incorporating the proprietary technology we have developed, this powder has been put to practical use. By achieving the targeted characteristics of the materials and performance of the part, we were able to reduce the size of the reactor part, which helped to reduce its cost.

Since Daido Steel's soft magnetic powder was used as a

raw material for the reactor part in Toyota Motor Corporation's Prius, which was launched in 2009, the Company has striven to provide a stable supply of this material for 13 years and contributed to the reduction of CO₂ emissions.

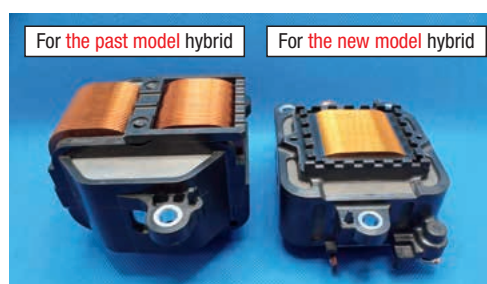

https://www.daido.co.jp/about/release/2023/230208_reactor.html (Japanese only)

3. Training of development personnel

① Utilization of international exchange system

We hope we will expand our perspective using the international exchange system in Japan and overseas to develop a mindset that looks beyond the Company. In addition, we will develop the human resources needed to change the Company, including considering exchange systems with venture companies to give employees new experiences in different cultures.

Changes in the results of domestic and international exchanges (R&D personnel) (Persons)

FY	2018	2019	2020	2021	2022
Study at Japanese university	0	2	0	2	3
Overseas study	2	0	0	2	0
Guest engineers	1	1	1	1	1

② Collaboration with universities and external institutions

We are working to turn staff with almost no knowledge of motors into experts capable of designing cutting-edge motors by dispatching them to the Motor Research Center in Daido University, which has been established as an endowed university course. We are also continuously developing human resources in fields beyond motors that are expected to grow in the future, such as magnetic materials. Below is an example from the previous fiscal year.



③ AI education

All staff at the Corporate Research & Development Center are learning about AI because we consider the utilization of AI to be necessary for future R&D activities. There are individual differences between personnel who just learned foundational knowledge and those who are data scientists, but materials and process researchers must be trained to at least reach the level of being able to utilize AI. Further, in order to raise materials development staff as data scientists, we will aim to raise knowledge about AI by various methods, including sending staff to university doctorate courses.

Participation in the Materials Open Platform for Permanent Magnet by the National Institute for Materials Science (NIMS) and four magnet manufacturers

In May 2022, Daido Steel, TDK Corporation, Shin-Etsu Chemical Co., Ltd., and Hitachi Metals, Ltd. launched the Materials Open Platform for Permanent Magnet (Magnet MOP), centered around the National Institute for Materials Science (NIMS).

With Magnet MOP, we seek to contribute to the realization of carbon neutrality by improving performance and reducing rare elements in the motors that are expected to be widely used in electric vehicles. For this reason, we are developing tools that will enable us to rapidly develop materials with the

required properties for each application. For material design and process optimization in tool development, we apply world-class microstructural analysis technology and data-driven research on magnet materials. Furthermore, in order to involve not only NIMS researchers but also university personnel, we are also promoting personnel exchanges with universities that use the cross-appointment system.

Daido Steel will dispatch six employees to the Magnet MOP and will train the personnel responsible for magnet development, which is expected to grow.

 https://www.daido.co.jp/about/release/2022/0530_nims.html (Japanese only)

Toward the creation of new value and performance

Society is currently in the midst of a transformation. Especially during such a time, we also need new value and performance. We view this as an opportunity, and as we take on challenges in fields with which we have had no contact up to now, we will

support the foundations of society by increasing the speed of R&D while enjoying close internal and external collaborations, and generating materials with special value and special performance.

Manufacturing Technology Strategy

“Based on high manufacturing capabilities that support manufacturing, we will accelerate portfolio reform and the development of carbon-free technology and respond to the diverse needs of our customers.”



Director, Managing Executive Officer
Tadayuki Kashima

The strength of Daido Steel’s manufacturing technology

A history of developing proprietary manufacturing equipment with special features

Manufacturing technology is technology related to the equipment for manufacturing products and technology related to the know-how and processes of how to proceed in the process when using that equipment.

As a leading specialty steel company that predicts the needs of the times, Daido Steel has pioneered the development and introduction of advanced manufacturing equipment. For example, in the 1980s we developed our proprietary ELVAC® process (a consistent process of electric arc furnace, ladle refining, vacuum degassing, and continuous casting) in order to support the full-scale volume production of specialty steel for automobiles, and we have contributed to the motorization of Japan by maintaining a steady supply of high-quality specialty steel. In the 1990s, we developed and introduced the vertical, round cross-section continuous caster, which was unmatched by any other company, achieving the continuous casting of ball-bearing steel and heat-resistant steel.

In addition, with equipment such as the stainless steel vacuum refining furnace (VCR) and the electric arc furnace with rotating drive (STARQ®), we have collaborated with our Machinery Division and used our proprietary equipment to achieve volume production of products with special features, reduce costs, and reduce CO₂ emissions. Daido Steel's great strength is the fact that this equipment and these processes have allowed world-leading manufacturing with our own hands.



Vertical, round cross-section continuous caster



Electric arc furnaces with rotating drives (STARQ®)

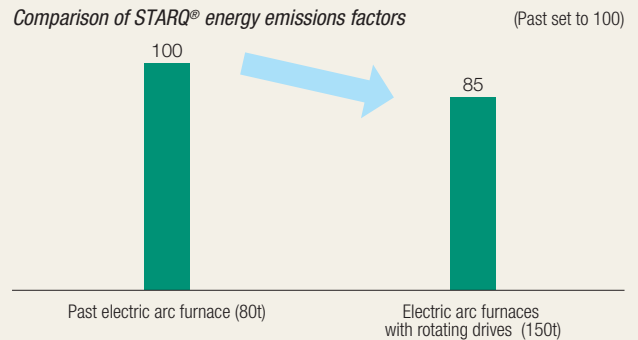

Manufacturing capabilities that utilize the equipment capacity and manufacturing know-how cultivated over our long history

Daido Steel is a comprehensive specialty steel manufacturer that has manufacturing equipment capable of consistently manufacturing most of the specialty materials used around the world, including carbon steel, case hardening steel, high-strength steel, bearing steel, free-cutting steel, stainless steel, tool steel, and superalloys. Leveraging our strengths, such as the manufacturing know-how to produce many models simultaneously on one line, the mechanisms that meticulously reflect our customers' needs through manufacturing that is consistent company-wide, and our short delivery times, we manufacture about 4,000 types of specialty steel products every year.

The know-how to manufacture diverse specialty steels to meet the needs of our customers is an asset we have fostered through co-creation and coordination with customers and research institutes over many years. We are able to create these 4,000 types of products because our long relationships with our customers allow us to fully understand their applications, and we have accumulated a collection of "recipes" based on their preferences. This detailed manufacturing expertise and the manufacturing capabilities that reliably implement it are the result of many years of improvements in our manufacturing processes, and they are an advantage that distinguishes us from the specialty steel companies emerging overseas.

At the same time, the fact that operators receive one year of training (Daido Steel Technical Training School) before being placed at a worksite and that we have a mechanism for cultivating high-quality operators, and our corporate culture in which operators themselves propose improvements every day and JK (*jisshu kanri*, or self-management activities by small groups) and TPM (Total Productive Maintenance) actively function as the basic activities in implementing these improvements, are

the source of our competitiveness in the manufacturing process. There are a total of 4,000 operators, including those at cooperating companies. Workplaces are made up of teams of about five people, and each team conducts self-management activities. There are various themes for these activities, from daily work efficiency to CO₂ emissions reductions. Monthly presentation meetings are held at each plant, and result presentation conferences attended by the whole company, including the President, are held twice a year. At these conferences, attendees' motivation is increased through awards; and these events continue even when performance is poor.

The Company has also been promoting DMK (Daido Monozukuri Kaikaku) activities since 2004. We have established the Advanced Manufacturing Department as a specialized department and, in conjunction with basic JK and TPM activities, we are working on the resolution of important issues, led by the worksites, in order to drastically improve productivity. For example, we have set up model workplaces and are engaging in activities to increase productivity by 30% and to foster leaders.



105th JK presentation conference (June 2023)



DMK activities poster for FY2023

**“Continuing to change,
advancing our technology,
moving into new areas”
Expanding awareness of the
manufacturing mindset to all
employees**

The Seven Teachings of DMK Activities

- 1 A place with no needs will not improve
- 2 Changing the perspective when looking at data reveals issues
- 3 Set your targets high and challenge them determinedly
- 4 Rough and ready is better than slow and perfect
- 5 Stick to the Three Reality Principle (go to the actual place, see the actual product, understand the actual situation)
- 6 Be obsessive about eliminating all waste
- 7 Be responsible for results and keep checking until the end

Manufacturing Technology Strategy

2023 Medium-Term Management Plan progress

Capital investment for transforming the product portfolio

With the shift to electric vehicles, as we foresee a decline in the volume of orders for specialty steel used in engines and transmissions, which have been our mainstay products until now, we must make a timely transformation of our portfolio to product areas where orders are expected to grow in the future, such as

semiconductors, aircraft, excavators, and the medical field. In the 2023 Medium-Term Management Plan, because we can expect fields such as high-performance stainless steel, superalloys, and titanium alloys to grow, we are enhancing measures to enhance the production capacity of the processes causing bottlenecks in these fields. Here are some examples.

- Strengthening heat treatment and secondary processing (PM: steel bar cutting processing) equipment in order to improve the manufacturing capacity for high-performance stainless steel (Chita Second Plant)
- Strengthening vacuum arc remelting (VAR) furnaces in order to improve the manufacturing capacity for high-performance stainless and superalloy (Shibukawa Plant, Chita Second Plant)
- Strengthening manufacturing capacity and competitiveness of superalloy steel: installation of raw material pretreatment equipment (Chita Second Plant), strengthening manufacturing capacity for superalloy rolled steel rods (Hoshizaki Plant)
- Strengthening manufacturing capacity of titanium: installation of remelting equipment for titanium (Chita Second Plant)

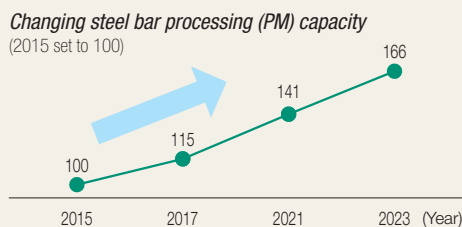

Steel bar processing (PM) line at Chita Second Plant

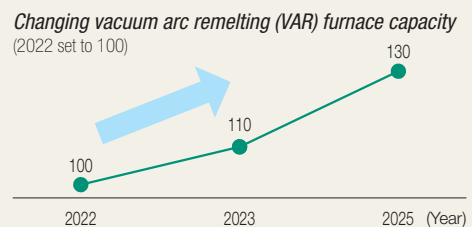

Vacuum arc remelting (VAR) furnaces at Shibukawa Plant

Realization of a green society (reducing CO₂ emissions)

In Daido Steel's manufacturing, the reduction of direct CO₂ emissions (Scope 1) is a major issue, and we must make continuous and systematic progress. In the 2023 Medium-Term

Management Plan, we are working from the perspective of improving the efficiency of burners typified by heating furnaces and soaking furnaces, and raising yield by increasing the unit weight of the processes downstream from rolling.

Example (1) of CO₂ emissions reductions at the plant

We are improving the LNG emissions factor by installing the oxygen-enriched combustion burners of the Chita Plant soaking furnaces. By increasing the oxygen supply, the amount of LNG required is reduced.

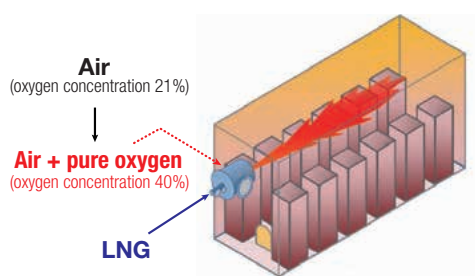
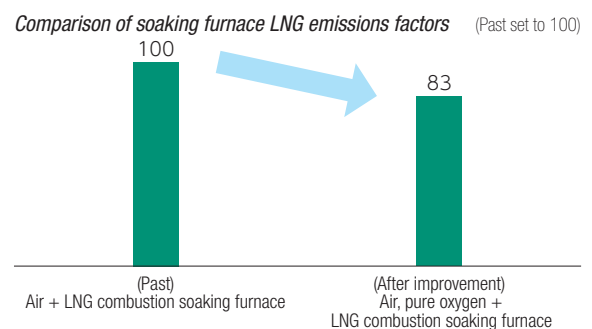

Illustration of oxygen-enriched combustion burners of soaking furnaces



Example (2) of CO₂ emissions reductions at the plant

We are improving yield by increasing the unit weight (1 ton to 2 tons) of Hoshizaki Plant secondary wire processing (WB: wire peeler process).

(Chita Plant rolled products)

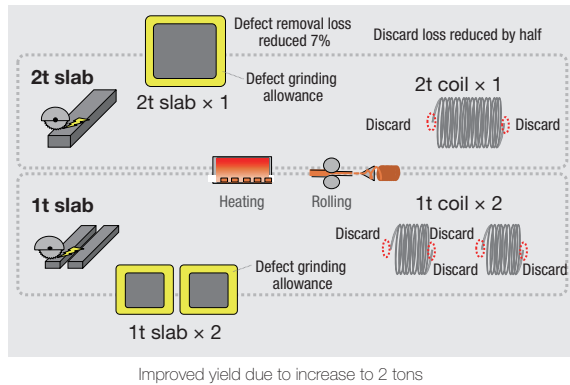

Hoshizaki Plant secondary wire processing (WB) 2-ton processing rate (Chita Plant rolled products)

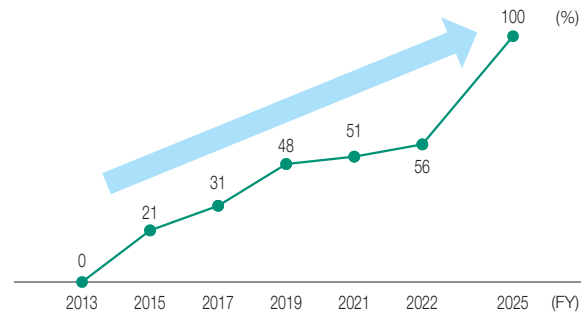

Recognition of issues and medium- to long-term key measures

Strengthen manufacturing capital and human capital while improving product portfolio

Customers' needs change with changes in society, and we need a decision-making process that looks far ahead to how our product portfolio will change as a result and to changing our manufacturing technology in our portfolio accordingly. For processes that cover the medium- to long-term, we must make determinations and decisions when the outlook is difficult to see.

In this situation, we can anticipate a healthy level of orders for superalloys and titanium alloys going forward, and we will determine the timing of investments and accurately invest in strengthening capacity so that we don't miss opportunities to get those orders. In addition, most of these markets are overseas. Superalloys in particular are attracting attention in Asian markets. In order to enter and expand our share in the markets, it is essential that we expand our personnel who are familiar with the markets, compliant with global standards and with the quality control systems required by our main overseas customers, and who can promote the acquisition of our customers' certifications. For this reason, we will actively move forward with personnel exchanges among plants.

Realization of a green society (reducing CO₂ emissions)

In Daido Steel's manufacturing process, we are developing and investigating the ultimate carbon-free electric arc furnace as a measure to drastically improve the electric arc furnace melting process, which has the greatest amount of CO₂ emissions. In cooperation with our Machinery Division, we are pursuing carbon-neutral manufacturing processes using the electric arc furnace with rotating drive and technology to preheat scrap with exhaust gas, which have already been developed.

Further enhancement of productivity through DX

We are currently selecting model workplaces and proceeding with the visualization of production sites, centered on the Advanced Manufacturing Department. First, we visualize the worksite, digitally gathering the signal information generated by the equipment, such as equipment operations, efficiency, and information about breakdowns and quality. Next, using data visualized by the worksite itself, we aim to eliminate operational waste, standardize maximum efficiency, and so on. At present, these activities have begun at some model workplaces, but we will be working on DMK activities to establish these worksite-led methods of production optimization as part of the Daido Steel Group's corporate culture.

Contributing to the diverse needs of future society

Daido Steel has generated trusted manufacturing supported by reliable manufacturing capabilities and numerous industry-standard technologies through co-creation with our customers.

Even as society attempts great changes in recent years, we

are resolutely continuing our efforts to maintain and improve the high manufacturing capabilities that are our strength, responding to the diverse needs of future society, and working to expand our entry into areas of growth.

Human Resources Strategy

“To maintain and improve our human capital, we will promote the establishment of initiatives and environments to “make the most of our people””



Managing Executive Officer
Takaaki Taketsuru

The human resources Daido Steel needs

Daido Steel has established the five conduct guidelines for the human resources who will realize our management philosophy. With the launch of the Project to Establish the Daido Steel Group Management Philosophy and Conduct Guidelines within the Company as we approached our 100th anniversary in 2016, the five conduct guidelines were devised in a review of the previous guidelines to align them with the current era. For example, one of the conduct guidelines is “Open to Challenges,” and in the

Company’s tolerance for challenges, the culture is one of “trying without fear of failure.” I believe this is our advantage. It puts into words and concisely summarizes the personnel behavioral patterns that have created this advantage, and I think this is what sustainable human capital looks like to us. In addition, even in times of rapid change, I believe that, to realize a green society, the needs required of the materials and an attitude that pursues potential will continue to be our advantage.

Daido Steel’s five conduct guidelines

- Aim High** : **Anticipate the new era and have a pioneering mindset**
As a professional, work on your own mission to the very end
- Sincere Action** : **Put yourself in the other party’s position and accept each other’s diverse values and presence**
Respond to stakeholder expectations
- Personal Growth** : **Always keep growth in mind when working**
Be willing to accumulate experience and improve yourself
- Team Strengths** : **Gather the wisdom of the Group beyond the organization**
Get things done with cooperation and a sense of urgency
- Open to Challenges** : **Pioneer a new era with an open mind**
Face difficulties without fear of failure

Overview of human resources and organizational management initiatives

Human resources and organizational management	
Human resources development initiatives continuously implemented until now	Recently ongoing establishment of the "Making the Most of Our People" initiative and environment
<p>Developing expert human resources</p> <ul style="list-style-type: none"> ● Early-stage development system "Daido Steel Technical Training School" ● Ongoing development activities "DMK activities" <p>Developing staff human resources</p> <ul style="list-style-type: none"> ● Special training and education "Selective training for core human resources responsible for management" "Global human resources development (exchanges, etc.)" 	<p>The "Making the Most of Our People" initiative</p> <ul style="list-style-type: none"> ● Extension of the retirement age (raising the retirement age from 60 to 65) ● Diversification of recruitment (from a single cohort to year-round recruitment) ● Diversification of human resources (encouragement of active roles for women, recruitment of foreign nationals) <p>Establishing the environment</p> <ul style="list-style-type: none"> ● Promotion of work style reforms ● Promotion of health and productivity management ● Update employee dormitory facilities

Human resources development initiatives

Developing people through expert courses

The source of Daido Steel's continued ability to steadily produce high-quality materials is the highly-skilled and highly reliable human capital at our manufacturing sites. For our new recruits, we maintain the Daido Steel Technical Training School, a training facility established in 1952. Recruits spend approximately one year at the school. During this time, not only do they learn the basic knowledge and technology they will need as experts in specialty steel manufacturing, but we also support them as they learn to live independently as working adults and company members. We say that manufacturing is developing people, and we believe that this policy of valuing the development of people, which dates back more than 80 years to the days of the school's predecessor, the "Technician Training School," continues to this day.

Turning to the development of people at our manufacturing sites, our DMK (Daido Monozukuri Kaikaku) activities are also essential. Before these activities began in 2004, we had found capital investment difficult due the economic slump, but orders rapidly increased after that and we promptly needed to increase productivity. Our factory capabilities were tested as we wondered how best to increase productivity by 30%. With the idea of rejecting the status quo, a specialized unit supported our activities, shared wisdom, and invested management resources in a timely manner, enabling the Company to exert all its capacity and increase productivity. We felt the true potential of the Company's factory capabilities, and these activities, which produced big results through an accumulation of small improvements, have continued for over 20 years, becoming the basic activities of Daido Steel's manufacturing.

Developing people through staff courses

In the management departments and the sales, R&D, and manufacturing technology departments, we have set the specific behavioral patterns expected at each grade of occupational ability, bearing in mind the development of human resources who can put the

five conduct guidelines into practice, and are conducting education and training based on structures we have created. We have summarized this content as the skills development guidebook, and disseminated the content as human resources development targets, and we are using it as employee evaluation standards.

In addition to education according to the grades of occupational ability, we have assembled education and training systems that support the growth and challenges of each employee, including the overseas trainee and international exchange system for global human resource development, the encouragement of the acquisition of various qualifications, and the selective training to develop the core human resources who will be responsible for management in the future.

The overseas trainee and international exchange system has been in place for decades and covers a wide range of goals, from foreign language studies to the acquisition of specialized knowledge and business skills in different cultures. Employees who have returned from exchanges have said that the experience brought them a variety of good operational results.

There are various selective education options which, in addition to learning about the ideas and differences of other people through discussions with members gathered from various other companies and business departments, are also enormously useful for building personal connections with people both inside and outside the Company.

In recent years, collaboration with diverse other industries and globalized responses have become essential, and we recognize that focusing on the new possibilities for Daido Steel that will accompany external environmental change and increasing the number of personnel who are able to act autonomously will be a challenge in the future. We will work to support improving skills through reskilling in order to solve issues.

Education for employees ▶ P.83



Practical training of students at Daido Steel Technical Training School



Internal selective training

Human Resources Strategy

The “Making the Most of Our People” initiative

One of the conduct guidelines, [Sincere Action], incorporates the meaning “accept each other’s diverse values and presence” and expresses Daido Steel’s diversity initiatives and attitude. As it becomes increasingly difficult to secure personnel due to the impact of the declining birthrate and aging population, it is essential to establish a workplace environment in which people respect and acknowledge each other’s differences, regardless of gender, nationality, values, sexual orientation, or disability. We launched a diversity promotion project in 2014, and since 2018 we have been promoting activities centered around the Diversity Section in the Personnel Department.

Encouragement of active roles for women

The issues in Daido Steel’s diversity promotion action plan are that there are few women in management and few opportunities for career support and career development that take into account life events, and a corporate culture that promotes diversity has not been cultivated enough. To resolve these issues, we have set the following targets and are implementing a variety of measures.

Diversity ▶ P.81–83

Diversity promotion action plan

[Plan Period]

April 1, 2021 to March 31, 2026 (5 years)

[Targets]

- Increase the percentage of next-generation lead supervisor positions responsible for management held by women to 17%. (12%→17%)
- Increase the retention rate of female employees hired 9 to 11 business years ago to 80%. (33.3%→80%)
- Conduct initiatives to support the career development of women.
- Sustain and promote the creation of a culture that accepts and makes the most of diversity.

We have also set the target number of women in managerial positions in 2030 to 30 (15 in 2022).

Furthermore, in the future, we believe it will become important to enhance our “Making the Most of Our People” activities even more than before in order to address various changes in the business environment. We will promote and investigate diversity initiatives from a variety of perspectives, including the encouragement of active roles for women.

Change of the retirement age to 65

With the shrinking labor force and in light of perspectives such as maintaining and improving factory capabilities, in 2023 we changed the retirement age system from 60 to 65. In this way, employees will fully demonstrate the skills and knowledge they have cultivated, and those skills will be securely passed down.

Diverse hiring methods

Nowadays the mobility of human resources has increased. At Daido Steel, we have reexamined the restricted policy of recruiting new employees as a single cohort, which we and other companies have used until now, and we are considering switching to a policy of year-round recruitment that includes mid-career employees. This will enable us to secure the personnel required for the Company’s operations in the future, and to acquire different types of professional personnel, who will be immediately work-ready, demanded by our business strategy.

In addition, hiring foreign nationals with diverse backgrounds and values will lead to invigoration of the Company. In recent years, we have also worked together with university career centers to continue to promote the hiring of international students studying in Japan.

Establishing an environment that supports “Making the Most of Our People”

As an environment that supports “Making the Most of our People,” Daido Steel is promoting safety and health initiatives and work style reform initiatives. In particular, we are concentrating on improving expert engagement of the approximately 2,000 people supporting our manufacturing line. At the moment, the issues of a high turnover rate among young employees and the lack of a sense of worksite solidarity have been highlighted by a lack of communication at our manufacturing sites, and for Daido Steel as a manufacturing company, this has become a major problem that we cannot overlook. As an activity to increase their

engagement, therefore, in 2021 we began the “Making a company that people look forward to working at every day” project. This a support activity to bridge the generation gap between young people and the leader class as well as the lead supervisor class above that. This is an activity with the Chita Plant as a model workplace, but it will be rolled out to the entire company by making it available to be conducted autonomously.

As an activity to further increase engagement, the employee dormitories in the Nagoya and Shibukawa areas are also being rejuvenated.



Illustration of completed employee dormitory (Motohamaryo)

Safety and health initiatives

Creating a workplace where employees can work with peace of mind and each employee remains physically and mentally healthy are parts that can be called the framework of human capital management. The basic principle of Daido Steel is safety and health are the source of happiness and the foundation of corporate management, and we strive to eliminate occupational accidents and promote health and productivity management.

At worksites these days, in addition to the problem of young employee turnover, there is an increase in the number of young employees who, unaware of hazards in their own workplaces, are subject to accidents while working as usual without noticing dangerous situations. A new mechanism is needed to improve safety sensitivity. Since 2022, one such mechanism has been assigning 74 veteran employees, who are well-versed in safety education, as "safety evangelists" at each production site. In addition to on-site guidance by these safety evangelists to young employees and inexperienced members, and improvements in their sensitivity to danger, this initiative improves safety by increasing communication and fostering a sense of unity.

Elimination of occupational accidents ▶ P.77,78



Safety evangelist poster

As health and productivity management, we are also working to improve physical and mental health, and to set a rate of 50% or higher for the evaluation "I work with mental and physical vitality" as a KPI. Going forward, we will collaborate with industrial health staff and the safety teams at each plant to enhance health and productivity management initiatives.

Promotion of health and productivity management ▶ P.79,80

Initiatives to reform work style

Amid the changes to the environment surrounding the image of work, such as the declining working population and the diversification of work styles, we are promoting activities at Daido Steel for various initiatives centered around the new work style reform working group (WG) to realize a work life balance through work styles that match each employee.

Work style reforms ▶ P.84

Toward further enhancements to corporate value

As I said at the beginning, we foresee great changes in the business environment surrounding Daido Steel in the future. In our human capital management, the Company must put into practice the five conduct guidelines established in 2016 and evolve constantly, and as management, we must steadily implement the "Making the Most of Our People" initiative and the establishment of the "Making the Most of Our People" environment. In my heart, I'm really glad that I joined this company. And I have a strong desire to increase the number of colleagues who want to make Daido Steel a more attractive company. For this reason, to address environmental changes, we will consider promoting mechanisms for the acquisition of new knowledge and skills as well as increasing the career development options available. Our goal is to further enhance our corporate value by promoting activities that increase employee engagement and make them feel glad to have joined Daido Steel.



DX Strategy

“Increasing added value provided to customers by digitalizing and visualizing internal operational data and enhancing our ability to use it”



Director, Managing Executive Officer
Akihito Kajita

DX ensures sustainability

As a specialty steel manufacturer with an extensive product lineup, our manufacturing comprises a wide variety of production processes including steel manufacturing, heat treatment, rolling, and cutting. Recent advances in IT technology, particularly in the generation and use of data, will transform production processes in the future and hold the potential to substantially increase productivity, quality, and more. The skillful use of data will be largely determinative of corporate competitiveness in the future.

In addition, the core systems that have long supported these production processes have accumulated the Company's manufacturing expertise over many years and have become systems that literally support the Company's backbone. We believe that transforming this into formats that are highly flexible and enable easy use of will be an extremely important DX topic for

enhancing productivity company-wide and ensuring business sustainability into the future.

IT budget trends

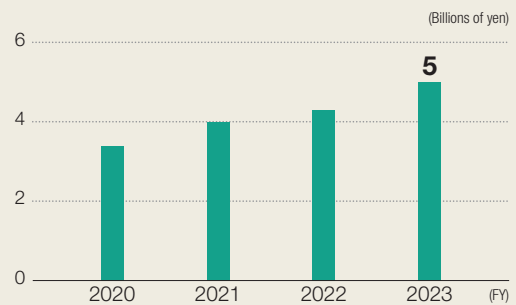

Current status of initiatives

Raising the efficiency of head office divisions and OA-related work

We are increasing the efficiency of head office divisions and OA-related work by making maximum use of devices including mobile PCs, tablets, and smartphones as well as various application tools. We used the COVID-19 pandemic as an opportunity to introduce communication tools and take other measures to establish remote work environments, and we made rapid progress in reforming work styles and raising work

efficiency. In the current fiscal year, the entire Group worked to replace applications with new cloud-based applications for the email, document, and schedule management systems that had been in use for many years in an effort to raise the efficiency of OA-related work even further. We are also actively conducting trials of new digital products, such as generative AI, which has recently become a major topic, and we are continuously exploring the possibilities of their use in internal operations.

Raising productivity in manufacturing divisions

At our production sites, we are promoting the use of data in wide-ranging fields including making the operation visible, detection of abnormalities, and safety activities and we are working to improve productivity and reform operations. Examples include performing equipment inspections using drones, using AI technology to visualize and automate skilled labor that in the past was performed by people, and using smart watches to ascertain the locations and health status of employees.

The implementation of smart technology at the Chita Second Plant early in the previous fiscal year has produced advances in operations and quality control through visualization of various types of information, implementation of paperless operations, labor-saving through remote monitoring, and other effects. When we install new equipment in plants in the future, we plan to establish IT foundations by incorporating these smart technology approaches. We also believe that it is necessary to focus our efforts in areas such as cross-plant data management as an IT foundation that can raise the production capacity of high value-added products company-wide.

Examples of recent initiatives

Creation of a remelting material management system at the Shibukawa Plant

The maintenance of remelted materials at the Shibukawa Plant comprises various processes, and because managing the order of processes and storage locations is complex, until now, these processes have been managed using paper forms. We recently developed an open system that achieves automated data input and visualization of production schedules through maximum utilization of mobile PCs and smartphones, leading to higher productivity and preventing human errors. At the Shibukawa Plant, a production site for free forging products, we are investigating links to improvements in various secondary processes based on this mechanism.

Improvement of remelting material management at the Shibukawa Plant

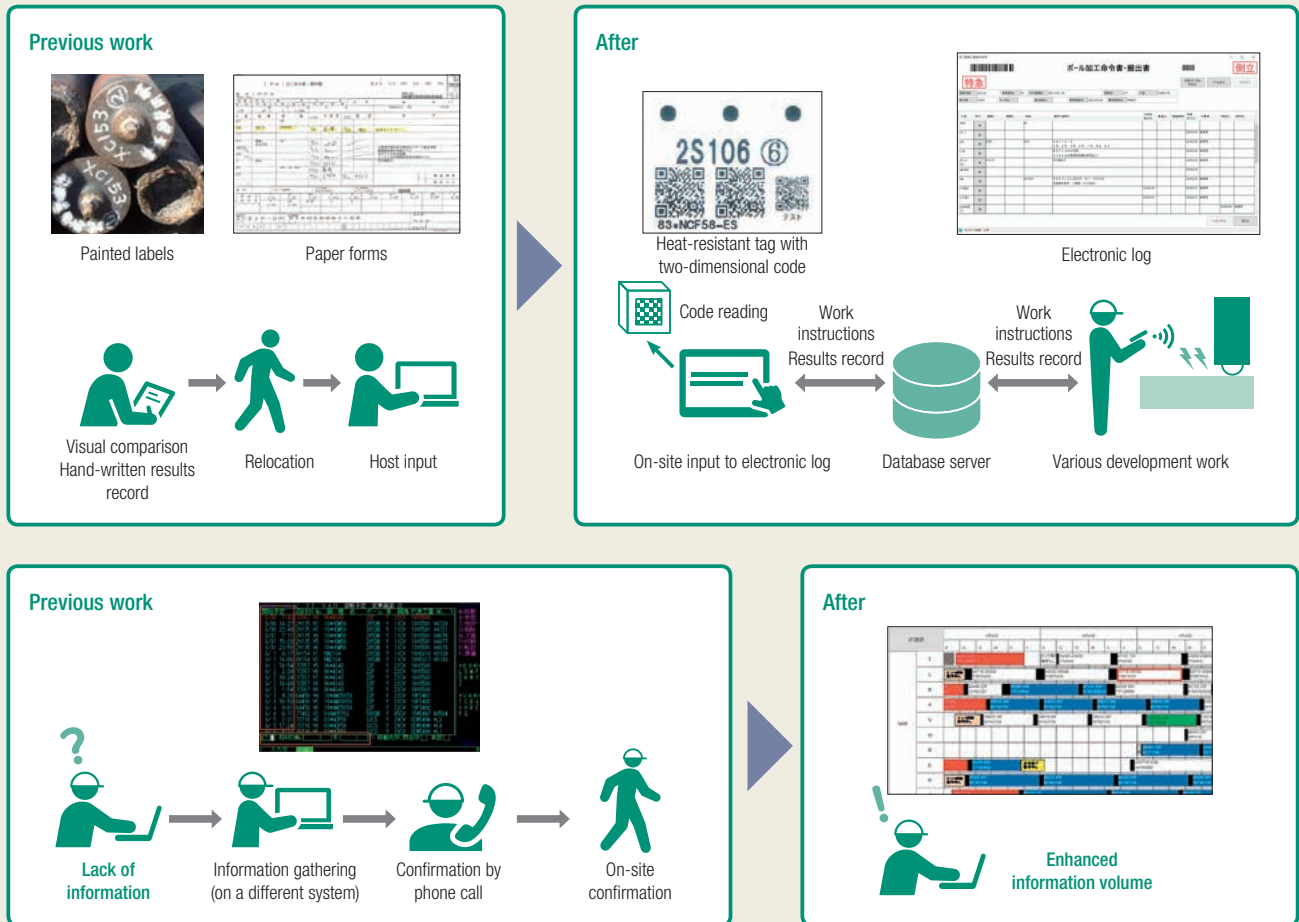

DX Strategy

Utilization for R&D

At our Corporate Research & Development Center, we are undertaking materials informatics (MI) and process innovation using machine learning including AI as well as numerical optimization methods.

Some initiatives have produced the effect of reducing new material development lead times through the collection and organization of existing data using MI. In addition, there are indications that AI analysis (image machine learning) can be applied to substantially reduce work times in the quantification work of structural observation, which is essential for developing materials. We believe that continuing these measures and expanding them to various materials development and process technology development fields will lead to an increase in the added value provided to customers in the future through accelerated product development, shorter delivery times, and substantial improvement of production efficiency.

Materials informatics initiatives in R&D

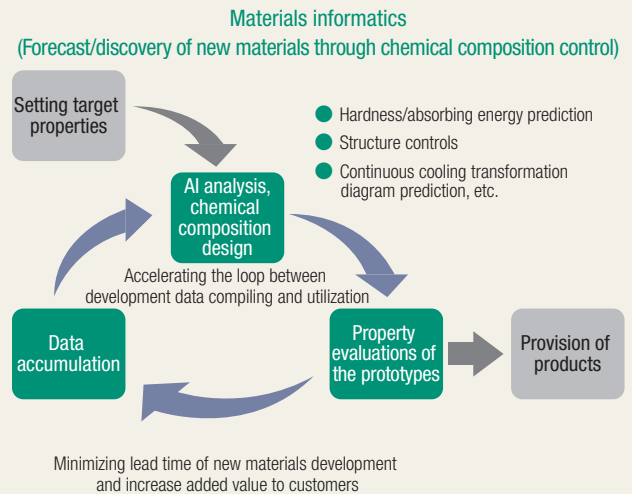

Development of core systems

In the process of implementing DX, creating a picture of the future status of host-based core systems that have been in use for many years has become an important issue. Although host-based core systems are stable due to their structures, they are lacking in flexibility in terms of external connections and other aspects, and there are difficulties relating to data use and coordination. Also, in light of recent trends relating to host computer manufacturers, we believe it is necessary to anticipate the risk that hardware devices will not be supplied over a certain long term period as well as the risk that it will be difficult to recruit engineers who understand the host programming languages.

These core systems have massive numbers of logic circuits embedded and are literally systems that support the backbone of the Company by contributing in real time to production operations. A fundamental review of these core systems and setting a

direction such as transitioning to online or cloud-based computing can substantially raise operational efficiency and productivity throughout the Company and raise the added value that we provide to customers even further and can also lead to avoiding the various risks that will arise from the continued use of the host computers.

Depicting our vision of future core systems and developing them will require some effort, expense, and time, but we believe that this is an important topic that must be addressed from a medium to long-term perspective. We established an investigation team in the IT division to (1) ascertain current conditions concerning the degree of complexity, black box, and bloat of systems, (2) research conversion methods, and (3) investigate component structures using hub functions.

Promotion organization

In the DX promotion organization, the IT Planning Department supervises the overall effort while the IT Planning Department handles projects related to OA-related and existing systems, the Corporate Research & Development Center handles projects for AI utilization, and the Advanced Manufacturing Department, including equipment technology development, handles projects to improve efficiency attached to production facilities.

The IT Committee, which is held once every three months, confirms the overall policy and discusses the promotion of major projects.

DX Promotion Organization

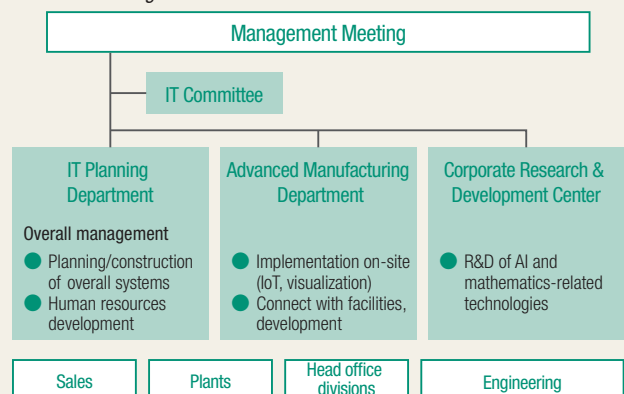

Education for employees

There is a sense that our employees have an adequate mindset concerning data utilization including understanding the operating status of equipment and quality by using data and devising innovations for improvement, but we are working to create opportunities for employees to learn about the latest technologies and examples of their use such as deep learning, big data utilization, and various analysis technologies in ways adapted to their specific business needs and roles.

With regard to data scientists, who hold the keys to data utilization, we developed 60 AI technology developers and users by 2022, and they have already started measures to solve internal problems. We are also reinforcing IT literacy education through training for new employees and rank-specific training in an effort to raise IT use levels company-wide, and for employees in staff positions, we measured knowledge levels concerning data

utilization and provided work-related educational content. In addition, we are working to instill a company-wide corporate culture of using IT and making business improvements through measures such as specialized education for leaders who have

responsibility for providing guidance and collaborating on data utilization in each department and conducting training for managers and supervisors.



Status of internal IT training

Cyber security measures

Cyberattacks have become increasingly advanced and intricate in recent years and security risks are increasing year by year including multiple instances in Japan of harm where key corporate data was encrypted and a ransom was demanded for release of the data. Until now, we have implemented countermeasures at

appropriate levels including developing information management rules, taking defensive measures, and making backups, and currently, we are implementing measures with a focus on the following points.

- ① The parent company plays a central role in efforts to raise the levels of countermeasures with the aim of achieving compliance with the National Institute of Standards and Technology (NIST) by the entire Daido Steel Group including domestic and overseas companies
- ② In addition to strengthening existing defensive measures, we develop countermeasures premised on intrusion including detection and isolation
- ③ We establish a Computer Security Incident Response Team (CSIRT) and Security Operation Center (SOC) for the entire Daido Steel Group including overseas sites and are establishing systems for responding to emergencies

Increasing provided value through a DX spiral

When observing DX from a technological perspective, we can see the spread of various types of sensors that support the IoT, high-speed communications technologies including 5G, the expansion of cloud computing, and advanced AI technologies including deep learning, and these technologies are evolving on a daily basis including the emergence of generative AI. In addition, the spread of devices such as smartphones and tablets has become an important aspect of DX.

The Company has used these technologies to solve various problems in internal operations and to reform ways of working, but two new sensibilities have emerged.

The first is that the idea of how to utilize these DX technologies in actual work is crucial. We believe that developing human resources who have a deep understanding of internal operations, have knowledge concerning DX technologies and examples of their use, and can integrate these two areas of knowledge to generate innovative ideas will be extremely important for implementing DX.

The second point is that data has value only if it can be used.

There are many different types of data within the Company including data on core systems and data from various sensors, and is believed that the volume of data is increasing greatly every day, but this is separate from whether the data can actually be used, and steady system-related efforts are necessary to make this data usable.

There are still variations in the degree of digitalization and data conversion in internal operations and the level of visualization of that data, but if work-related data is visualized in the form of line charts, graphs, and so on, various things can be noticed more than expected, and we have developed a renewed awareness that this can be useful for increasing efficiency, improving quality, and so on. If we can make data usable, we will notice new things and generate new ideas, which will generate a spiral that leads to the expansion of data foundations. We believe that expanding this spiral to the entire Company will lead to enhanced competitiveness and increased added value provided to customers.

Financial Strategy

We will conduct rigorous balance sheet management and strategic growth investment to achieve corporate growth based on stable financial foundations with the objective of increasing shareholder returns.



Director, Managing Executive Officer
Akihito Kajita

Profits in FY2022 reached record high levels

Sales volume in fiscal 2022 was down year-on-year due to a decrease in automobile-related orders caused by the extended slump in automobile production, effects on semiconductor-related orders from inventory adjustments through the end of the fiscal year, and other factors. Meanwhile, raw material prices rose to levels higher than in the previous year due to effects of international market conditions and supply constraints, and energy costs also increased significantly due to higher crude oil and LNG prices. In response, we undertook continuous measures to thoroughly reduce costs and correct sales prices. These measures, coupled with the effects of portfolio reforms

that we have been implementing, including expansion of high value-added products, resulted in the Company achieving new record highs for each measure of profit in fiscal 2022.

There are concerns regarding the risks that prices for raw materials, energy, and materials will increase even further in fiscal 2023, but we expect that automobile-related demand will gradually recover as shortages of parts, particularly semiconductors, are steadily eliminated. In addition, as cost-cutting measures and sales price corrections become more widespread, we expect that we will be able to maintain the same profit levels as in the previous fiscal year.

FY2021 and FY2022 results and FY2023 forecast

(1,000 tons, ¥100 million)

	FY2021 results	FY2022 results		FY2023 forecast			
	Full-year	1H	2H	Full-year	1H	2H	Full-year
Sales volume of steel products	1,253	540	545	1,085	544	585	1,129
Net sales	5,297	2,819	2,967	5,786	2,900	3,100	6,000
Operating income	370	232	238	470	190	280	470
Ordinary income	392	241	240	481	200	285	485
Extraordinary income or loss	15	-4	16	12	-	0	-
Corporate tax, etc.	-138	-54	-75	-129	-70	-95	-165
Profit attributable to owners of parent	269	183	181	364	130	190	320

New accounting and tax initiatives

We are currently making preparations to apply the International Financial Reporting Standards (IFRS), an important issue in terms of our accounting systems, and to date, we have performed full consolidation of Group companies and standardization of fiscal year ends. Through the application of the IFRS, we seek to reinforce Group business management systems by using global standard accounting rules throughout the Daido Steel Group and to deepen understanding of the Group by overseas investors.

In terms of taxes, we introduced a group income and loss

sharing system in fiscal 2022, which allows the profits and losses of wholly-owned domestic subsidiaries to be shared across the entire Group. As a result, in fiscal 2022, profit and loss sharing, tax effects at subsidiaries, and other factors had the effect of raising profit attributable to owners of parent by approximately ¥3 billion. We expect certain benefits of profit and loss sharing and other measures to continue to have an effect in this fiscal year and later.

Review of product portfolio and pursuit of profitability

One of the Company's characteristics as a specialty steelmaker is an extensive variety of products, and I believe that the sources of this variation are the diverse production lines at our plants and the manufacturing technologies that enable us to manufacture products made from various types of steel across the different factories as needed.

In order to create each product, we begin from upstream steel production "melting and casting," go through a multi-stage process such as heat treatment and machining, and create multiple products through shared equipment and processes. Under this backdrop, in order to manage profitability, it is important that we fully grasp the costs that span hundreds of thousands of items across each product, such as costs of personnel, raw materials, energy, as well as depreciation expenses for equipment required in production processes. Because improving productivity in upstream processes contributes to reducing costs of a wide range of products, we have formed a structure that sets detailed targets and manages capital investment and initiatives to increase productivity of plants and various production lines.

The precise costs that we determined in this way serve as the basis for product prices, and also function as fundamental data that supports decision-making concerning sales strategies and production operations. We established approximately 20 Strategic Business Units (SBUs) into which our products and businesses are categorized, and determining the status of profit and loss individually for each SBU leads to decision-making concerning sales strategies, production operations, and so on. The recent sharp increases in raw materials prices and energy costs led to the precise determination of the impacts on products and business in each SBU and action including product sales price corrections.

In addition, profitability management of each SBU is important for making decisions regarding review of the product portfolio and the pursuit of profitability by the Company as a whole. One example of a review of the product portfolio is the decision that the Company made in fiscal 2022 concerning the die forging

products business to withdraw from in-house production of die forged products and production of housing products and to specialize in the production of high-speed precision forged products. At the same time, we are making strategic, large-scale capital investments in future business growth areas such as expanding vacuum remelting furnaces to increase production capacity of high-performance stainless steels, superalloys, titanium products, and other products.

Change in operating income by segment (consolidated)

(Billions of yen/three-year total)

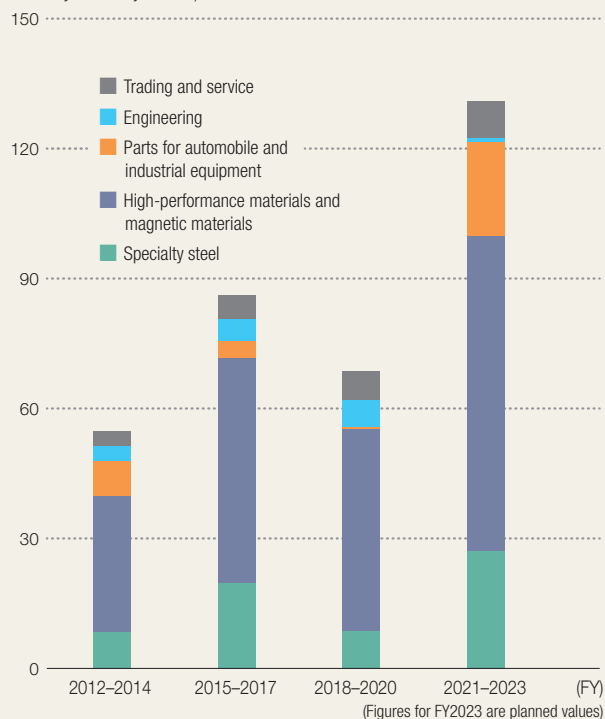

Financial Strategy

Measures for improving the balance sheet and cash flows

The Company's balance sheet includes a substantial volume of inventory assets necessary for production processes, and the balance of trade payables is low in comparison to the balance of trade receivables. As a result, our business structure requires large sums of operating capital. Because the Company produces many different types of products with high added value, we use multi-stage production processes that require considerable production lead time, and a certain degree of inventory assets is essential. In addition, the relatively short payment periods for raw materials and energy are also a factor behind the low balance of trade payables in comparison to the balance of trade receivables.

As a result of these circumstances, the increases in raw materials prices and energy costs since about 2020 have led to increases in operating capital, and as a result, in fiscal 2021, despite a substantial increase in profit for the fiscal year, free cash flows turned negative and interest-bearing debt increased. Based on a rough calculation, if prices relating to manufacturing increase by 20%, the shareholders' equity ratio will drop by approximately 4 points, the D/E ratio will increase by approximately 0.15, and ROIC will decrease by 0.4% due to the increase in operating capital and the accompanying increase in interest-bearing debt. This has renewed our awareness of the degree of impact that rising prices for goods has on the Company's cash flows and various financial and profitability indicators.

In fiscal 2022, the pace of increases in raw material prices and

energy costs slowed, and as a result free cash flows turned positive and interest-bearing debt is trending downward, but we remain aware that streamlining inventory assets by raising production efficiency and reducing the imbalance between trade receivables and trade payables or financial issues that we must steadily address.

In addition, reducing cross-shareholdings, which account for a significant portion of the balance sheet, is also a financial issue to be addressed. The Company's cross-shareholdings are primarily shares of partners or buyers related to product development and manufacturing or suppliers of raw materials and resources. These are held to construct solid relationships with partners and buyers through joint development and so on, but in light of recent social developments regarding corporate governance, we have taken measures until now to reduce these cross-shareholdings. We continued these measures in fiscal 2022, and as of March 31, 2023, the ratio of cross-shareholdings to net assets was 24.3% on a basis including deemed cross-shareholdings and 17.7% on a basis excluding deemed cross-shareholdings. Our short-term target is to reduce the cross-shareholdings to 20% or less of net assets on a basis including deemed cross-shareholdings by March 31, 2024, which is the final year of the 2023 Medium-Term Management Plan. Our policy concerning the proceeds from the sale of cross-shareholdings is to actively invest the funds in measures for achieving carbon neutrality.

Changes in free cash flows (before deducting dividends)

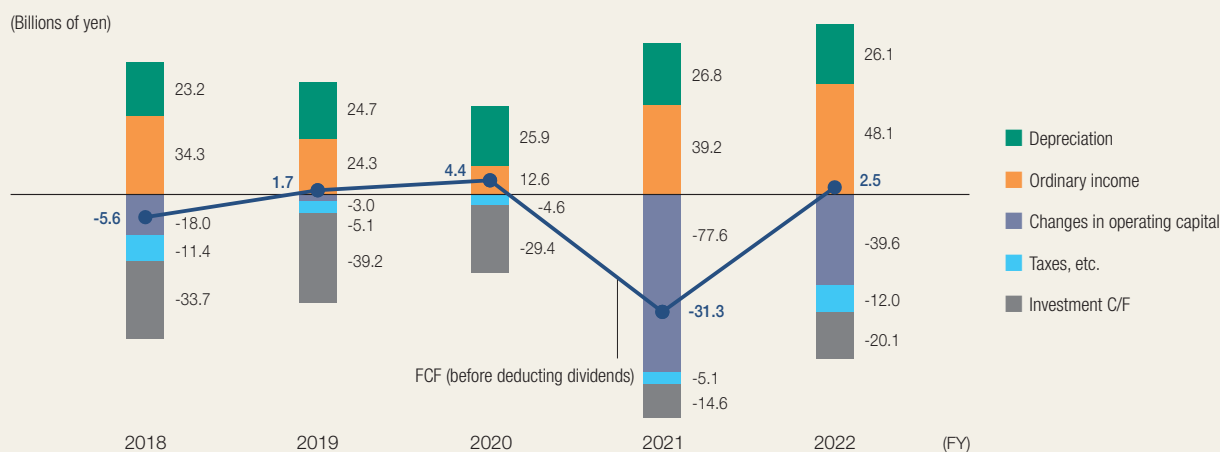

Current investment plan

Under the 2020 Medium-Term Management Plan, we proactively made investments that exceeded depreciation expenses, such as strengthening secondary processing capabilities, reinforcing remelting equipment, and building the Nakatsugawa Advanced Magnetic Materials Development Center in order to enhance manufacturing capabilities in strategic areas such as high-performance materials and magnetic materials. These investments are firmly linked to transforming the product portfolio and the corresponding enhancement of profitability. Under the 2023 Medium-Term Management Plan, we plan to make strategic investments to reform the portfolio and improve cost and productivity even further and to make capital investments at high levels with a focus on investments for reducing CO₂ and rebuilding business foundations. We project that total investment over three years including IT investment for developing DX foundations and reforming working styles and human resource investment to develop and secure human resources will be ¥90 billion.

Accumulated total from FY2021 to FY2023 (forecast)

¥90 billion

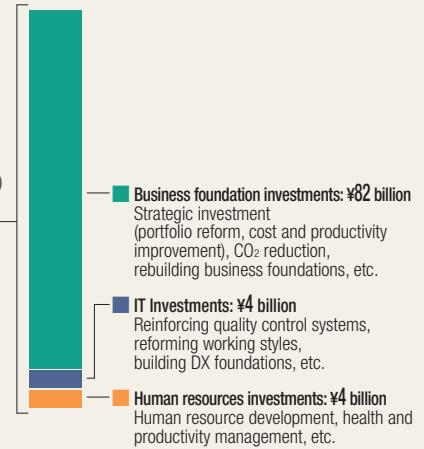

Policy on shareholder returns

The Company's dividend policy is to maintain stable shareholder returns, and in the 2023 Medium-Term Management Plan, we raised the shareholder returns target from a dividend payout ratio of 20%–25% to a dividend payout ratio of 30%. Based on this level, the Company declared a dividend of ¥230 per share for fiscal 2022, a record high amount. Going forward, we will actively

make strategic growth investments to capture growth markets in conjunction with the electrification of vehicles and decarbonization and we will invest in carbon neutrality while performing balance sheet management with the objectives of increasing profits further and raising the actual amounts of shareholder returns.

Dividends

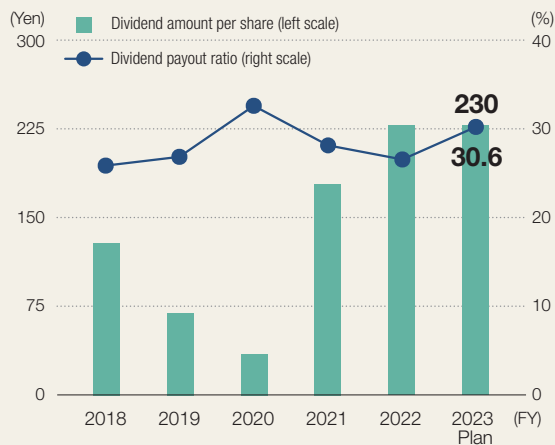

Business Strategy

Specialty Steel Business Division & Tool Steel Business Division



Responding to the changing needs of society through an extensive product lineup and advanced technological and proposal capabilities

Representative Executive Director,
Executive Vice President and General Manager,
Specialty Steel Business Division

Toshiaki Yamashita

The Specialty Steel Business Division handles sales of specialty steel and high-performance specialty steel, mainstay products of the Company that comprise more than 80% of all sales. The products that the division handles are used in a wide range of fields including automobiles, industrial machinery, semiconductor manufacturing equipment, medical, and consumer-related. In addition, the Tool Steel Business Division handles mold steel used in the manufacture of automobile parts, consumer electronics products, and mechanical equipment. The pace of change in society has been increasing, exemplified by initiatives for achieving a decarbonized society and technological innovation in the automobile industry referred to as CASE. We actively respond to new needs through our extensive product lineup and advanced technological and proposal capabilities.

Main products and contributions to society

Specialty Steel Business Division

- **Specialty steel: Steel bars and wires such as carbon steel and alloy steel for machine structures, spring steel, bearing steel, and free-cutting steel**

These products are used in a wide range of applications as structural components in automobiles (engines, drive system parts, etc.), construction machinery, industrial machinery, and so on. In conjunction with future advances in CASE, the need for materials used in gear reducers for high-performance e-Axles in automobiles and other components will increase even more. We

are honing our materials development and proposal capabilities and actively communicating with customers to achieve carbon neutrality.



Specialty steel (steel bars)

- **High-performance specialty steel: Stainless steel, superalloy bars and wires, titanium, and welding material**

Stainless steel is a type of steel that has excellent characteristics including corrosion resistance, workability, and heat resistance and is used in a broad range of applications including kitchen utensils, building materials, machine structural parts, medical devices and equipment, and chemical industry equipment parts. Our steel bar and wire products boast the top market shares in Japan.

Ultra-clean steel (CLEANSTAR) made using our specialized melting technology is used in the field of semiconductor

manufacturing equipment and will contribute to the development of a society where AI is common and digitalization has advanced.

Titanium has excellent properties such as light weight, high strength, corrosion resistance, biocompatibility, and absence of magnetism, and it is an environmentally friendly material suitable for recycling. It is also widely used in consumer-related fields (golf equipment, fishing equipment, eyeglasses, bicycles, and so on), particularly in medical.



Stainless steel materials (wires)

Tool Steel Business Division

- **High-performance tool steel**

Tool steel is used as a mold material employed in the manufacture of the many industrial products that we encounter every day including automobiles, consumer electronics, and food containers. Parts for which demand is expected to increase in the future in conjunction with the electrification of automobiles, such as motors and batteries, will require higher quality and more stable mold characteristics compared to earlier products, and consequently, we provide high-performance materials that can contribute to responses to these needs.

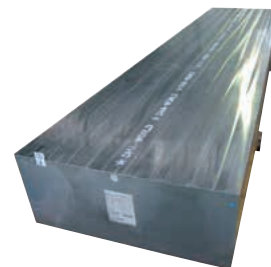

Mold steel

Progress and outlook of the medium-term management plan

Specialty steel

- Strengthen management' agility:** To respond in a timely manner to fluctuations in costs, in addition to the existing surcharge scheme for iron scrap, we are expanding the introduction of surcharge schemes for energy and other expenses.
- Boost the volume of base orders:** In anticipation of decreasing demand for specialty steel in conjunction with the spread of electric vehicles in the future, we are taking action to increase our market shares with existing customers and actively working to acquire business from new customers. We are also taking measures to ascertain needs for electric arc furnace materials to achieve carbon neutrality.
- Proactively expand sales of new products:** To meet demand in areas where growth is expected such as e-Axle gear reducers used in electric vehicles, we are developing products and working to expand sales.

Stainless steel, superalloy bars and wires, titanium, welding materials

- Actively expand sales of growth products:** In relation to semiconductor manufacturing equipment, we are reinforcing specialized melting and secondary processing, securing production capacity to meet the expanding demand for ultra-clean steel, and engaging in proactive sales activities to expand our share of the North American market.
- Develop new products:** In relation to hydrogen, we are developing steels that are resistant to hydrogen embrittlement and conducting public relations activities at exhibitions and so on. Going forward, we will make proposals to customers in

collaboration with pipe manufacturers. We will also expand sales in new fields such as titanium alloys for biological use, high-strength invar wire, and welding materials for additive manufacturing.

- Expand sales in overseas markets:** To expand market shares for high-performance materials in Asian markets, we established Daido Steel Materials Technology Shanghai Co., Ltd. as a sales base in China, established a secondary processing site in Thailand, and are taking measures to expand sales.

Tool steel

- Reinforce the earnings base:** We will transition to appropriate prices in response to higher costs for energy and materials and changes in prices for alloys and scrap. We will also take comprehensive measures to reduce manufacturing costs, particularly for melting processes, with the aim of enhancing our cost competitiveness further.
- Develop new products:** We will develop new products through co-creation with customers so we can respond to the need for high-performance mold steel suitable for new parts demand in conjunction with the electrification of vehicles.
- Reinforce sales networks:** In Japan, we will work to improve value provided through processing, heat treatment, surface treatment, and in other areas with a particular focus on Daido Die & Mold Steel Solutions Co., Ltd. Overseas, we will seek to enhance the functions of sales hubs in each country through active capital investment with a focus on the markets in India and Vietnam, where future growth is expected.

Daido Steel specialty steel demand forecast
(Index with FY2017 set to 100)

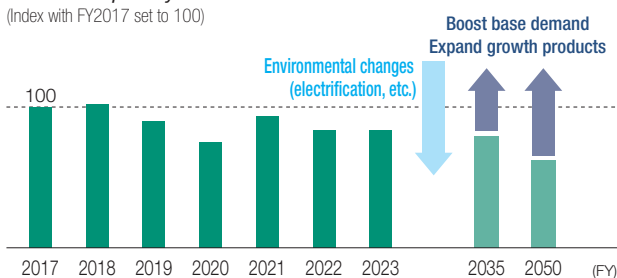

Changes in orders received for ultra-clean stainless steel
(Index with FY2017 set to 100)

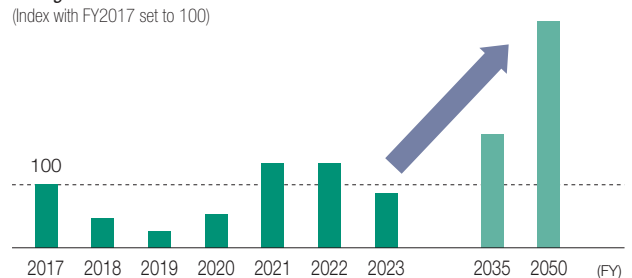

Long-term issues and outlook

Specialty steel/high-performance specialty steel

- Environmental awareness (risks and opportunities):** The decline in demand over the long term in conjunction with the spread of electric vehicles (EVs) will be unavoidable, but high-performance materials will be needed due to the advanced performance of automobiles and the global increase in semiconductor demand. Amidst these developments, we will reinforce measures in areas where substantial growth is expected including CASE, semiconductor-related products, and clean energy.
- Strengthen management' agility:** We will improve production efficiency in fields where existing specialty steels will remain in demand, such as automotive suspension parts and bearings, and build a structure that enables us to secure profits even as the volume of order declines.
- Respond to carbon neutrality:** Increases are expected in the need for specialty steel manufactured in electric furnaces, which have lower CO₂ emissions

compared to blast furnaces, particularly for automobile-related products. We will leverage the strong relationships with customers that we have built up over many years to identify needs and respond to them in a timely manner.

Tool steel products

- Expand the share of domestic mold markets:** The long-term contraction of the market is continuing, and lower demand due to declining domestic demand and other factors will be unavoidable, so we will work to expand our market share by developing new products and reinforcing collaboration with distribution companies.
- Reinforce activities in overseas markets:** In addition to the ASEAN region, there are strong expectations for growth in the Indian market and other markets, so we will actively reinforce our sales network to achieve continuous growth of orders received.

Fabricated Materials Business Division



Leaping forward and growing to become Asia's No. 1 manufacturer of superalloys and high-performance materials, contributing to the development of a sustainable society

Managing Executive Officer and General Manager,
Fabricated Materials Business Division

Muneyoshi Matsuo

The Fabricated Materials Business Division supplies superalloys and high-performance materials that are essential for solving global-scale issues relating to the SDGs, such as protection of the global environment, energy-saving, and raising standards of living, with the world's highest levels of quality (Q), cost (C), and delivery times (D), fulfilling our social responsibilities by growing into a trusted and valuable specialty steel manufacturer. In addition, we set as an important policy that will apply going forward the maximization of use of alloy scrap generated during manufacturing processes including scrap generated in-house, scrap generated by customers, and scrap traded in the market, and we are working to create sustainable business schemes.

Main products and contribution to society

The Fabricated Materials Business Division contributes to social development by providing numerous high-performance materials that support the daily lives of people and production activities in various industries in areas such as (1) aircraft, (2) ships, (3) semiconductors, (4) heavy electrical equipment (thermal and nuclear power), (5) drilling, and (6) industrial machinery. With regard to aircraft and ships in particular, by supplying nickel-based alloy materials that are essential for increasing engine efficiency and reducing CO₂ emissions to engine makers, we are contributing to engines that can comply with strict environmental regulations. In addition, we are working with engine makers to increase material recycling rates by collecting scrap generated during product manufacturing processes and products discarded at the end of their useful lives.

Nickel alloy shaft and disc material for use in aircraft engines

In 2014, the company became the first specialty steel manufacturer in Asia to make a full-scale entry into the market for nickel superalloys for aircraft (rotating components), which require extremely high quality and rigorous management. We obtained manufacturing certification from U.S.-based PW, and delivered 6,000 shafts and other parts over the next eight years.

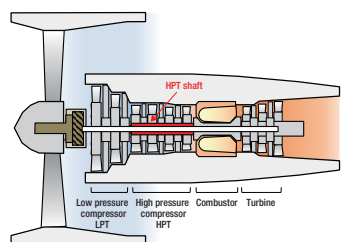

Aircraft engine



Product appearance

Based on performance that was free of even a single problem during that time, we are currently conducting negotiations to receive certification from a second and third manufacturer. In the future, we plan to sign long-term nickel superalloys business contracts with the world's leading aircraft engine manufacturers and to expand this business through a sustainable scheme whereby scrap generated in customer processes is used as a raw material.

Nickel alloy exhaust valve for large ship engines

Regulation of NO_x and SO_x emissions from ships is becoming stricter as an environmental countermeasure, and operating conditions in marine areas subject to environmental regulation have become more stringent. As a result, the progression of exhaust valve corrosion from sulfur (S) in fuel has become an issue concerning ship engines in recent years.

We developed DSA760, a Daido Steel brand steel that can reduce the progression of corrosion by up to one-third compared to earlier materials. We received certification from major ship engine manufacturers and have been producing approximately 800 units per month since 2018. We are working to create a sustainable recycling system by collecting discarded valves arising as a result of replacement demand and using the discarded products as raw materials for replacements.



Large ship

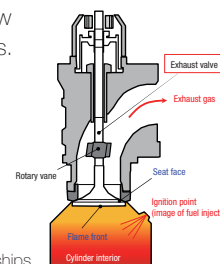

Engine for large ships



Product appearance

Progress and outlook of the medium-term management plan

Under the 2023 Medium-Term Management Plan, we set (1) expanding high-performance materials, (2) entering the decarbonization business, and (3) expanding global sales as our fundamental strategies and set targets of achieving a superalloy ratio of 34% and overseas sales ratio of 41% and increasing orders received by 8% (compared to fiscal 2017 to 2019) through portfolio reform.

Regarding strategy (1), we have taken action with a focus on expanding sales of superalloys, particularly nickel-based alloys. Achievements include reducing manufacturing lead times by investing in super alloy production equipment through fiscal 2021, increasing manufacturing certifications obtained from customers, increasing domestic and overseas orders for super alloys by conducting aggressive sales activities targeting overseas super alloy wholesalers and introducing brand steels, and as a result, the ratio of superalloys among orders received reached 51%, substantially exceeding the target.

Concerning strategy (2), we are conducting technical exchanges concerning the high-performance materials needed for a hydrogen-based society including hydrogen stations and hydrogen carrier ships and materials for nuclear and fusion power generation, which are power sources that do not emit CO₂. We already started production of prototypes of some of these materials, and we are establishing the foundations for the next medium-term period.

Regarding strategy (3), we developed sales human resources to target overseas markets and assigned personnel to overseas sites, resulting in a rapid expansion of overseas customers, and the ratio of overseas sales reached 53%, greatly exceeding the target as well.

By carrying out these three fundamental strategies, the Fabricated Materials Business Division has made progress on

portfolio reforms and obtained orders in 2022 that greatly exceeded the target (195%), and is expanding even further in 2023.

In this fashion, recognition of Daido Steel as a supplier of high-performance materials and superalloys is rapidly increasing both in Japan and overseas. We will also continue our efforts to be recognized as Asia's No. 1 manufacturer of superalloys and high-performance materials in the near future.

Changes in orders received for fabricated materials and 2023 Medium-Term Management Plan

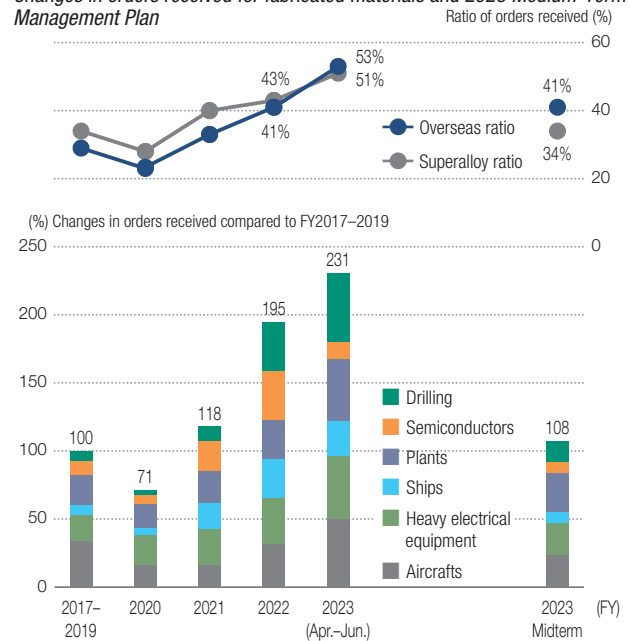

Long-term issues and outlook

Current orders for fabricated materials have reached the limit of the production capacity of facilities, and consequently, developing production systems that can supply products without delay has become a priority issue. In addition, using scrap that includes nickel will be essential for achieving a sustainable superalloy business. To address these issues, we have decided to invest in three VARs, one forging heating furnace, and a second raw material pretreatment device to increase the capacity of vacuum induction melting (VIM) furnaces, vacuum arc remelting (VAR) furnaces, high-speed four-surface forging machines, and preprocessing (crushing and washing) of scrap materials in order to recycle scrap that is generated in-house and by

customers, which are all essential for superalloy production. In addition, we are working on the development of schemes in the aircraft and drilling fields, areas where the use of superalloys is high, to conclude contracts for prices premised on recovering scrap with customers who have the largest shares of the global market. We see the tripling the superalloy and high-performance bar businesses, which have high levels of social contribution, from current levels while simultaneously recycling scrap generated within business schemes as raw materials to develop the superalloy business into a stable and sustainable business as a long-term issue.

Orders received for superalloys and high-performance materials

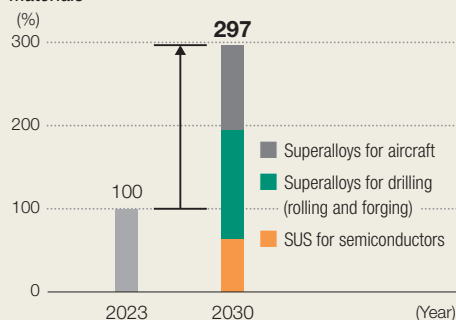

Fabricated superalloy and high-performance product sales expansion plan





Supporting society with products that provide advanced functions that go beyond specializations

Managing Executive Officer and General Manager,
Functional Products Business Division

Ikuo Sugie

With contributing to a sustainable society through the expansion of business in fast-growing fields and strengthening future “earning power” so that the Daido Group can achieve sustainable growth as its core mission, the Functional Products Business Division focuses on product lines equipped with functions such as magnetism and thermal expansion for which growth in demand is expected in conjunction with the electrification of automobiles and industrial equipment.

The Division consists of various product departments for steel strips, metal powders, and electronic materials and the Next-Generation Products Development Center, which is tasked with the creation of new products and businesses.

Main products and contributions to society

Contributing to society with functional products

The Functional Products Business Division plans to expand business in fast-growing fields, such as CASE, ICT, and next-generation energy, as post-internal combustion engine products and will contribute to society.

Examples of products

- Strip steel made from soft magnetic/resistive materials, strip steel for separator in SOFC/SOEC, high magnetic flux density strip steel for motor cores
- High-performance soft magnetic powders, lithium-ion battery anode material (active material), magnetic shield sheets, etc.

Steel Strip Department

- Current sensor relays and torque sensors for CASE and electrical and electronic devices, soft magnetic materials for shunt resistors, resistor materials, sealing materials
- Corrosion resistance materials for semiconductor equipment, welding materials for ships and industrial machinery
- Shielded boxes for high-precision industrial inspection, shielded rooms for high-precision medical imaging



Hermetic seals (stem and lens caps)



Bellows (semiconductor manufacturing equipment components)

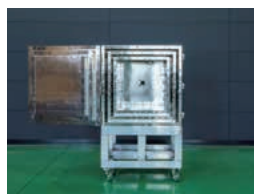

High-performance magnetic shielded boxes

Metal Powder Department

- Corrosion and heat resistant materials for automobile internal combustion engines
- High-performance soft magnetic powder for xEV (powder for reactors)
- Stainless steel powder for sintering for automobile parts and industrial machinery, powder for 3D additive manufacturing



Reactor component for HEVs and PHEVs

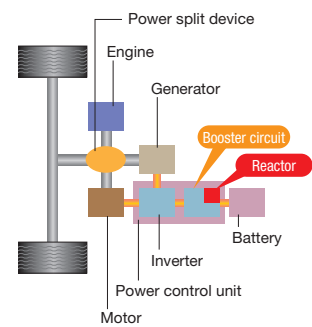

Example of use in a booster circuit for HEVs and PHEVs

Electronic Materials Department

- Power semiconductors, touch panels, target materials for functional thin films for cutting tools, etc.
- Optical encoders for high-precision servo motors, point light source LEDs for optical sensors



Point light source LED

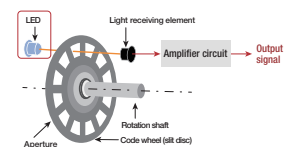

Example of use in an optical encoder

Progress and outlook of the medium-term management plan

In fiscal 2022, adjustments of automobile-related inventories became prolonged in conjunction with the shortage of parts including semiconductors, and sales volume was down year-on-year due to the slump in electrical and electronic device and semiconductor related demand, but electric vehicle related demand was strong. In addition, the transfer of higher prices for raw materials and energy to sales prices progressed, and we achieved both our sales and profit targets under the 2023 Medium-Term Management Plan.

Steel Strip Department

The department achieved net sales of heat-resistant materials for internal combustion engine applications, its main products, as well as soft magnetic materials and resistor materials for CASE and electrical and electronic applications in excess of plans. The department is also developing new products, such as high-performance motor materials used in air mobility as well as steel strips used for methanation-related applications, which are attracting attention in relation to carbon neutrality, and is working to commercialize these new products for the future.

Metal Powder Department

Sales of products for automobile internal combustion engines, which account for a majority of product sales, remained strong as the department worked to enhance its cost competitiveness and engaged in co-creation with customers. In relation to CASE, the department is working to maintain and expand market shares for high-performance soft magnetic powders used in xEV reactors, develop next-generation models, and develop new applications such as automotive power inductors. The department is also focusing its attention on powders for 3D additive manufacturing and is reinforcing supply systems and expanding its lineup in anticipation of increasing demand in the die field including tool steel as well as for plants, power generation, and other applications.

Electronic Materials Department

Sales of target materials for functional thin films and point light source LEDs, the department's main products, remained strong. Regarding target materials for functional thin films, the department is developing new products and working to expand sales of products that meet changing needs, such as power semiconductor applications, an area where market growth is expected, and larger and curved automotive touch panels. For point light source LEDs, in fiscal 2022, the department tripled production capacity from the existing level and is taking action to reinforce supply structures and deploy new products.

Next-Generation Products Development Center

Progress in commercialization is being made in a number of themes, including materials for lithium-ion battery anodes (active materials). In addition, planning and development are underway in cooperation with individual product departments and the Corporate Research & Development Center concerning commercialization topics that apply new soft magnetic materials.

Net sales of the Functional Products Business Division

(Billions of yen) ■ Steel Strip Dept. ■ Metal Powder Dept. ■ Electronic Materials Dept.

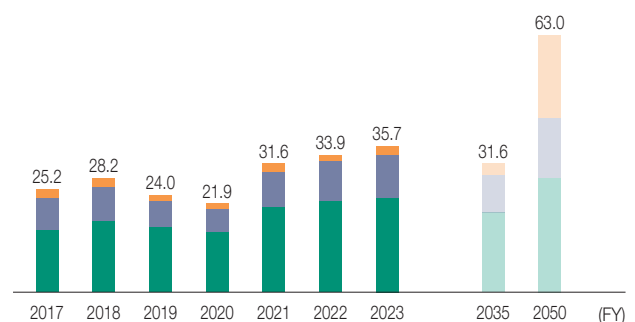

Long-term issues and outlook

We will expand business in growth markets including CASE, ICT, and next-generation energy, thereby contributing to society, while steadily overcoming issues.

Steel Strip Department

- The department will reform its portfolio and expand sales in growth markets including CASE and ICT.
- Development of new products and new technologies: The department will invest in the technologies, quality, and facilities necessary for expanding sales.
- Reinforcing business foundations: The department will reduce manufacturing costs, raise production efficiency, and reinforce production capacity.

Metal Powder Department

- Expanding growth products/deepening manufacturing processes: The department will deepen high-yield gas powder production technology, development of superalloys and high-performance powders, and secondary processing technologies including insulation coatings, etc.
- Creating future products: The department will develop powders for lithium-ion battery anodes, start mass production of automotive power inductor powders, and develop reactor powders for BEV charging and current collector powders for SOFC applications.

Electronic Materials Department

- The department will seek to expand business by increasing the number of products related to vehicle electrification and semiconductors and deploying applications for SmFeN magnetic powders.



“ Together, with passion,
and looking to the future,
we seek to create a sustainable society using thermal technology
with a focus on electric furnaces ”



Note: The SDGs characters of the Machinery Division



Thermo★tainable Experience the passion that enabled us to manage technology and together let's continue to challenge what is possible.

Note: The SDGs logo of the Machinery Division

Managing Executive Officer,
responsible for
Machinery Division

Yuji Noguchi

We are working to achieve the SDGs through thermo tech (thermal technology)

Daido Steel is one of the few companies in the world that not only manufactures specialty steel, but also designs and manufactures steel manufacturing facilities and heat treatment equipment including electric furnaces.

We have both the operational technologies and cutting-edge equipment technologies for high-efficiency production of steel products. By providing these technologies to customers, we are contributing to the realization of carbon neutrality in the world's industries.

In addition, environmental products that use our thermal technologies play a role in the circular economy by transforming waste into useful resources, and we will continue our contributions in this field for the development of a sustainable society in the future.

Main products and contributions to society

Contributions to green transformation (GX) with energy-saving products and environmental products

Ten of our products including the electric arc furnace with rotating drives (STARQ®) and Premium STC® Furnace (2nd generation) were selected for the Advanced Energy Conservation Investment Promotion & Energy Demand Structure Transformation Support Program as “advanced equipment and systems” certified by the Agency for Natural Resources and Energy under the fiscal 2022 revised budget.

● Steel making equipment: Electric arc furnaces with rotating drives (STARQ®)

The STARQ® electric arc furnaces with rotating drives are able to efficiently transfer heat by rotating the furnace body during scrap iron melting, reducing electric power input in achieving uniform melting. The 150 arc furnace STARQ® at the Chita Plant achieved a 15% improvement in energy consumption throughout the entire process from melting to casting compared to the earlier 80 arc furnace.



Electric arc furnaces with rotating drives (STARQ®)

● Heat treatment equipment: Premium STC® Furnace (2nd generation)

The Premium STC® Furnace (2nd generation), equipped with new functions to enhance energy savings and environmental performance, achieves substantial energy savings, improved IoT functionality, and shorter operating times compared to earlier STC furnaces and achieves a 15% reduction in fuel gas, 30% reduction in nitrogen gas, and 11% reduction in CO₂ emissions compared to standard model 20 furnaces.

● Environmental preservation equipment: Next-generation sewage sludge carbonization system (ultra-high-temperature carbonizing furnace)

In the environmental products field, we developed ultra-high-temperature technology for heating sludge to 1000°C or higher for steaming and incineration. The carbonized products created using this technology can be used as high value-added products including activated carbon alternatives and detoxified soil enhancement materials.

(A Ministry of Land, Infrastructure, Transport and Tourism's 2023 Breakthrough by Dynamic Approach in Sewage High Technology Project (B-DASH project))

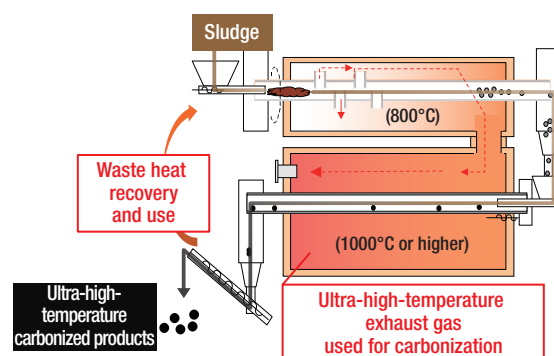

Next-generation sewage sludge carbonization system (ultra-high-temperature carbonizing furnace)

Progress and outlook of the medium-term management plan

We are carrying out the 2023 Medium-Term Management Plan with the fusion of industrial furnace operating technologies and equipment technologies as the key concept.

Proposing products and services aimed at achieving carbon neutrality

- We are taking active measures to expand sales with a focus on products that reduce CO₂ emissions including electric arc furnaces with rotating drives (STARQ®) and the Premium STC® Furnace (2nd generation).
- We developed the radiant tube type Daido burner, which uses hydrogen as fuel (press announcement made in December 2022). We will continue to develop demonstration models with the aim of installing them on the next-generation Premium STC® Furnace.

Image of our future product portfolio

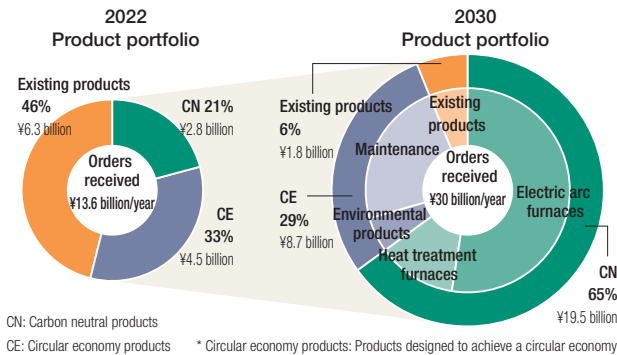

Develop global markets that contribute to the growth of the Asian market

- We will build collaborative relationships with partners in Asia so that we can contribute to the development of customers' overseas supply chains.
- We have made long-term appointments of engineers to some regions and are working to expand our maintenance service territories.

Transforming business and manufacturing by using digital technology

- We are working to introduce a unified management system for product information that links design and installation data and to reinforce 3D CAD with the aim of raising operational efficiency to expand sales.

Machinery Division order results and plans

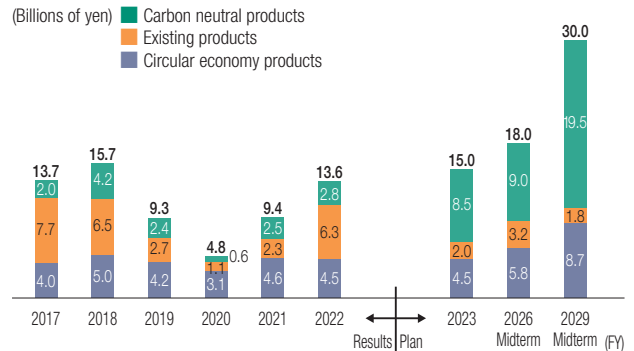

Long-term issues and outlook

Developing innovative carbon neutral technologies

- By developing electric arc furnace technologies, which must continuously evolve, we will play a leading role in achieving carbon neutrality of the world's steel making equipment.

- We will achieve practical use of hydrogen combustion burners and adopt methanation technology for commercial furnace applications to advance development for achieving the complete decarbonization of heat treatment furnaces.

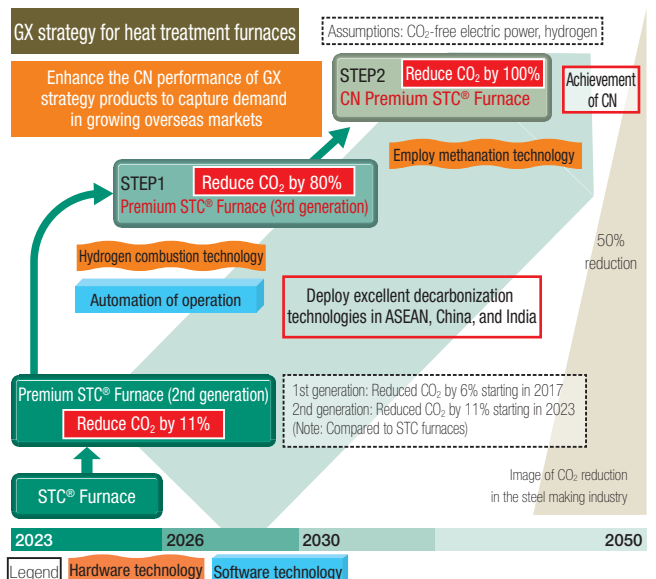
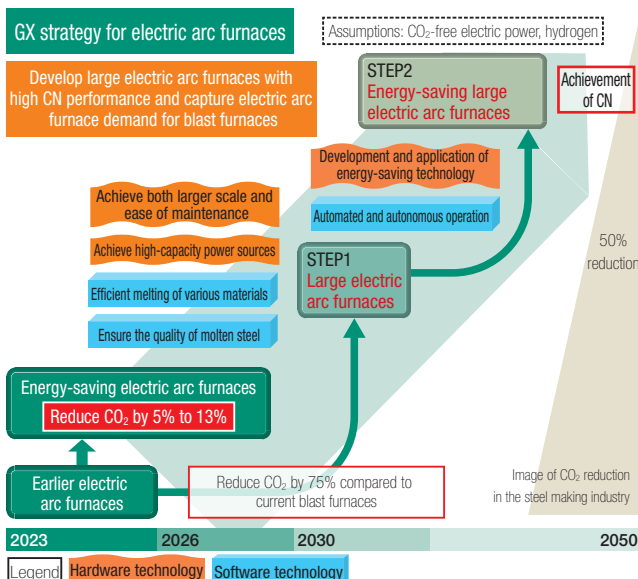

Response to Risks and Opportunities

The environment in which we operate is undergoing dramatic change, such as mobility innovation and energy transition to address climate change. By grasping the risks and opportunities arising from changes in the external environment and making use of them as new business opportunities, we aim to grow sustainably and enhance corporate value by identifying and promoting the thematic roles that the Company should fulfill.

Materiality		Risk	Opportunity	Daido Steel's role
1. Preservation of the global environment (business activities)	(1) Initiatives to address climate change	<ul style="list-style-type: none"> Rise in electricity costs caused by increased use of renewable energy Increase in operating and material procurement costs caused by the introduction of carbon pricing Suspension of operation at plants of the Company or its suppliers caused by increases in natural disasters 	<ul style="list-style-type: none"> Gain the trust of stakeholders in the Prime Market, and improved evaluations, by addressing TCFD 	<p>Reduce CO₂ emissions through the use of energy-saving measures, decarbonized electricity sources, and decarbonization technology</p> <hr/> <p>Enhance absorption of CO₂ through activities that preserve the natural environment</p>
	(2) Transition to a circular economy	<ul style="list-style-type: none"> Increased procurement costs due to higher prices for high-grade scrap, for which demand has increased Operation of plants in regions with a risk of water shortages 	<ul style="list-style-type: none"> Reduced material costs through expansion of the use of cheap scrap Reduced disposal costs through expansion of the 3Rs of by-products Reduced risk of drought through effective utilization of water resources 	<p>Recycle scrap through use of electric arc furnaces</p> <hr/> <p>Expansion of the 3Rs of by-products</p> <hr/> <p>Conservation of water resources</p>
2. Preservation of the global environment (product supply)	(3) Technological innovation for energy transition	<ul style="list-style-type: none"> Reduced demand for internal combustion engine components caused by progressive shift to electric vehicles Reduced share due to competitors taking technological lead 	<ul style="list-style-type: none"> Increased demand for high-performance materials caused by the progressive shift to electric vehicles Increased demand for hydrogen embrittlement resistance steel and other products arising from progressive shift to hydrogen society 	<p>Supply of products to address mobility innovation</p> <hr/> <p>Supply of products that contribute to clean energy business</p> <hr/> <p>Supply of products that support technological innovations addressing environmental regulations</p>
	(4) Improvements in energy efficiency	<ul style="list-style-type: none"> Reduced share due to competitors taking technological lead Entering market for electric arc furnaces for blast furnace manufacturers 	<ul style="list-style-type: none"> Rising in demand for electric arc furnace materials and engineering to address environmental issues Rising demand for transition from converters to electric furnaces Rising demand for equipment driven by progressive shift to digital society 	<p>Supply materials, facilities and equipment with outstanding energy efficiency</p>
	(5) Effective utilization of natural resources	<ul style="list-style-type: none"> Unstable procurement of raw materials such as rare metals associated with high environmental and social risks Water-related risks: drought, extreme torrential rain, water pollution 	<ul style="list-style-type: none"> Rising demand for products that do not use natural resources such as rare metals Rising demand for products that facilitate the conservation and effective utilization of water resources 	<p>Supply products that conserve resources and do not include hazardous elements</p> <hr/> <p>Supply materials, facilities and equipment that contribute to the reduction and effective utilization of waste</p> <hr/> <p>Supply products that help secure water resources</p>

	Materiality	Risk	Opportunity	Daido Steel's role
3. Responsibilities and contributions to society	(6) Respect for human rights	<ul style="list-style-type: none"> Loss of business opportunities due to inadequate response to laws and regulations and the demands of society Reduced employee motivation and productivity due to inadequate initiatives within the Company 	<ul style="list-style-type: none"> Gain trust of stakeholders Enhance employee productivity through internal initiatives 	Strengthen global initiatives for respect for human rights
	(7) Human			
	1) Elimination of occupational accidents	<ul style="list-style-type: none"> Accidents and fires during operation of major facilities 	<ul style="list-style-type: none"> Enhanced productivity through safe operation 	Roll out key health and safety measures
	2) Promotion of health and productivity management	<ul style="list-style-type: none"> Infectious disease leading to paralysis of business activities 	<ul style="list-style-type: none"> Enhanced productivity due to promotion of better health 	Promote better health among employees
	3) Promotion of diversity	<ul style="list-style-type: none"> Failure to recruit and develop sufficient personnel due to the declining birthrate and aging of society 	<ul style="list-style-type: none"> Generation of innovation through acquisition of diverse human resources 	Recruit and develop diverse personnel Build a workplace environment that fosters sense of job satisfaction
	4) Work style reforms	<ul style="list-style-type: none"> Reduced employee motivation due to inadequate workplace environment and employment systems 	<ul style="list-style-type: none"> Enhanced productivity due to workplace environment and employment systems that are in tune with the times 	Enhance productivity by promoting work style reforms
	(8) Social contribution initiatives	<ul style="list-style-type: none"> Dilution of reason for existence due to reduced contribution to local communities 	<ul style="list-style-type: none"> Promote improved assessment of the Company and increased employee motivation through encouragement of cooperative activities 	Promote communication with local communities
(9) Supply chain management	<ul style="list-style-type: none"> Negative impact of inadequate response to environmental and human rights issues by business partners 	<ul style="list-style-type: none"> Raise level of mutual sustainability through synergies with business partners 	Strengthen cooperation with business partners through partnership system	
4. Strengthening governance	(10) Strengthening of corporate governance	<ul style="list-style-type: none"> Continued existence of company endangered by governance failures 	<ul style="list-style-type: none"> Gain trust of stakeholders through sound governance 	Reinforce structures such as Board of Directors, committees Promote various corporate governance initiatives
	(11) Risk management and compliance	<ul style="list-style-type: none"> Trouble caused by inadequate response to risks Fines and administrative punishment caused by inadequate response to laws and regulations and the demands of society 	<ul style="list-style-type: none"> Maintain normal corporate activities by taking the initiative in responding and gain the trust of stakeholders 	Identifying risks and addressing key risks Promotion of thorough compliance
	(12) Stable supply of high-quality products	<ul style="list-style-type: none"> Diminished trust due to product liability damages and the occurrence of recall expenses 	<ul style="list-style-type: none"> Enhance trust among customers through consistent supply of high-quality products 	Thorough quality management and quality improvements
	(13) Stakeholder communication	<ul style="list-style-type: none"> Declines in share prices, hiring, and shares due to diminished trust 	<ul style="list-style-type: none"> Gain the trust of stakeholders by improving understanding of the Company 	Enhance dialogue Promote disclosure of information

Progress of Actions for SDGs and Materiality

No.	Materiality	2023 Medium-Term or Long-Term Targets/KPIs	
1. Preservation of the global environment (business activities)			
(1)	Initiatives to address climate change	Reduce CO ₂ emissions through the use of energy-saving measures, decarbonized electricity sources, and decarbonization technology	<ul style="list-style-type: none"> Promote "Daido Carbon Neutral Challenge" Reduce FY2030 emissions by 50% (compared to FY2013) Achieve carbon neutrality by 2050
(2)	Transition to a circular economy	Recycle scrap through use of electric arc furnaces	<ul style="list-style-type: none"> Promote recycling of main raw materials
		Strengthen "3Rs" for by-products	<ul style="list-style-type: none"> Promote recycling of by-products (slag, dust, sludge, etc.)
		Conservation of water resources	<ul style="list-style-type: none"> Promote recycling of water resources Thoroughly manage and reduce emissions of chemical substances
2. Preservation of the global environment (product supply)			
(3)	Technological innovation for energy transition	Supply of products to address mobility innovation and contribute to clean energy business	<ul style="list-style-type: none"> Develop and provide products to support CASE
			<ul style="list-style-type: none"> Develop and provide parts and materials to support the diffusion of hydrogen and ammonia businesses
(4)	Improvements in energy efficiency	Supply materials, facilities and equipment with outstanding energy efficiency	<ul style="list-style-type: none"> Develop and provide products to contribute to energy savings
			<ul style="list-style-type: none"> Develop and provide facilities and equipment to contribute to energy savings
(5)	Effective utilization of natural resources	Supply facilities and equipment to contribute to waste reduction and products to contribute to securing water resources	<ul style="list-style-type: none"> Develop and provide products to contribute to waste reduction and the effective utilization of water resources
			<ul style="list-style-type: none"> Develop and provide facilities and equipment to contribute to waste reduction and the effective utilization of water resources
3. Responsibilities and contributions to society			
(6)	Respect for human rights	Human rights initiatives	<ul style="list-style-type: none"> Firmly establish Daido Steel Group Human Rights Policy within Company, put in place systems and frameworks to expand activities
(7)	Human 1) Elimination of occupational accidents	Promote key health and safety measures	<ul style="list-style-type: none"> Ratio of accidents requiring time off work: 0.20% or lower Serious accidents: 0
	Human 2) Promotion of health and productivity management	Promote better health among employees	<ul style="list-style-type: none"> Promotion of health and productivity management Promote early discovery and treatment of poor health or mental illness, and raise health awareness Findings rate of 55% or lower, 50% or higher of responses of "I work with mental and physical vitality"
	Human 3) Promotion of diversity	Recruit and develop diverse personnel	<ul style="list-style-type: none"> Encouragement of active roles for women: raise retention rate (30%→80%) and ratio of female managers (double the 2022 rate in 2030 (2%→4%)) by providing career consultations and education such as selective role model training, percentage of next-generation management (associate senior staff) positions held by women 17%
		Build a workplace environment that fosters sense of job satisfaction	<ul style="list-style-type: none"> Job satisfaction awareness surveys and activities to foster job satisfaction
Human 4) Work style reforms	Promotion of work style reforms	<ul style="list-style-type: none"> Use IT to create efficient work styles regardless of location or time 	
(8)	Social contribution initiatives	Communication with local communities	<ul style="list-style-type: none"> Engage in more intensive communication about the environment with local communities
		Enhance absorption of CO ₂ through activities that preserve the natural environment	<ul style="list-style-type: none"> Reduce CO₂ through conservation of green spaces and greening activities
(9)	Supply chain management	Strengthen cooperation with business partners through partnership system	<ul style="list-style-type: none"> Collaborate on ESG issues throughout the entire supply chain: decarbonization, BCP, VAVE, compliance
4. Strengthening governance			
(10)	Strengthening of corporate governance	Reinforce structures such as Board of Directors and committees and promote various corporate governance initiatives	<ul style="list-style-type: none"> Expedite decision-making, enhance corporate value over the medium- to long-term Enhance effectiveness and transparency
(11)	Risk management and compliance	Identifying risks and addressing key risks	<ul style="list-style-type: none"> Evaluation of risks through periodic formulation and revision of risk map
		Promotion of thorough compliance	<ul style="list-style-type: none"> Firmly establish compliance mindset in all employees
(12)	Stable supply of high-quality products	Thorough quality management and quality improvements	<ul style="list-style-type: none"> Index of major quality incidents: 0
(13)	Stakeholder communication	Improved stakeholder engagement	<ul style="list-style-type: none"> Enhanced transmission of corporate information and promotion of communication with stakeholders

FY2022 Results and Current Initiatives	Reference Pages	Related SDGs
<ul style="list-style-type: none"> Reduced CO₂ emissions by 21% (compared to FY2013) (CO₂ emissions factor: -26%) 	P67-70	
<ul style="list-style-type: none"> 90% recycling rate for scrap products 80% recycling rate for by-products Recycling rate of over 90% for water Met all water discharge standards for all 41 managed items (Chita Plant, annual measurement) 	P71-72	
<ul style="list-style-type: none"> Available for volume production: steel for e-Axle gears, semiconductor manufacturing equipment materials, soft magnetic materials, high performance magnets, etc. Under development: electrodes for CO₂ recovery, materials for lithium-ion battery (LiB) anodes, specially-shaped and -oriented magnets, etc. Installed equipment to evaluate hydrogen embrittlement and corrosion resistance Available for volume production: jet engine shaft for aircraft, special molds (hot stamp, gigapress), etc. Participating in planning green innovation fund projects and the Materials Open Platform for Permanent Magnet Selected for the fiscal 2022 revised budget, Advanced Energy Conservation Investment Promotion & Energy Demand Structure Transformation Support Program as "advanced equipment and systems" (10 Daido Steel products) Available for volume production: Lead-free super free-cutting stainless steel for ballpoint pen tips, pump parts for desalination plants, etc. Under development: 3D manufacturing wires and powders, etc. Under development: "Demonstration of ultra-high temperature carbonization technology by adding value to sludge" selected for the FY2023 Breakthrough by Dynamic Approach in Sewage High Technology Project (B-DASH Project) 	P73 P74 P74	
<ul style="list-style-type: none"> Established the human rights policy (February 2023), signed UNGC and joined GCNJ (July 2023) Provided human rights education to all Company employees, delivered harassment education to a total of about 680 people (cumulative FY2022 total for Daido Steel Group) 	P75-76	
<ul style="list-style-type: none"> Ratio of accidents requiring time off work: 0.30% Serious accidents: 0 	P77-78	
<ul style="list-style-type: none"> 98.9% underwent thorough detailed examinations Smoking rate of 26.7% Findings rate of 70%, 35% of responses of "I work with mental and physical vitality" 	P79-80	
<ul style="list-style-type: none"> Female employee retention rate of 88.9% 15 female managers (2%) (May 2023), 9.4% of next-generation management (associate senior staff) positions (March 31, 2022) "Making a company that people look forward to working at every day" project ongoing since FY2021, office manager management training, began 360 degree evaluations 	P81-83	
<ul style="list-style-type: none"> Remote working ratio at head office departments: 46.9% 	P84	
<ul style="list-style-type: none"> Participated in the "Inochi wo Tsunagu PROJECT" in the Chita Peninsula Seaside Industrial zone Enhanced communication through opening of plant sites and support for cultural and sporting activities Surface area of plant green space: Daido non-consolidated 315,000 m², Daido Steel Group 187,000 m² (only plants subject to the Factory Location Act) Kutcharo Natural Forest Daido: surface area of green space 3,734,000 m² Nagiso Daido Forest: surface area of green space 21,000 m² (the area for which the Company is the "forest caretaker") Kisokoma Highlands: surface area of green space 1,431,000 m², Happudaira, Gunma: 2,079,000 m² 	P85-86	
<ul style="list-style-type: none"> Launched Daido Supplier Partnership system "DSP" (May 2022) Held partner meetings (May 2022) to publicize system 	P87-88	
<ul style="list-style-type: none"> Established Sustainability Committee (April 2022) Established ESG Management Department (January 2023) 	P93-98	
<ul style="list-style-type: none"> Updated the risk map for the 2026 Medium-Term Management Plan (during FY2023) Implemented third BCM training, held sixth Daido Steel Group CRM study sessions, subcommittee activities (a total of 13 times, attended by a total of 104 companies) Established Daido Group's Anti-Bribery Policy (June 2023) Reformed Daido Steel Group Corporate Code of Ethics (August 2023) Number of internal reports: 40 Note: All have been addressed 	P101-106	
<ul style="list-style-type: none"> Index of major quality incidents: 0.11 (index of FY2022 results taking the actual results from 2006 as "1") 	P107-108	
<ul style="list-style-type: none"> Conducted ESG briefings and events for individual investors (shareholders and investors) 	P109-110	

Preservation of the Global Environment

Initiatives to Address Climate Change

Status of Daido Steel initiatives to reduce CO₂ emissions and save energy

Status of initiatives to reduce CO₂ emissions derived from energy use

With our electric arc furnace process, Daido Steel is an energy-intensive business. We view reducing the CO₂ emissions of our energy sources as an important sustainability issue and are making it our top priority.

By establishing the three reduction measures of achieving drastic energy savings by combining existing technologies, using decarbonized electricity sources and improving consistent yield, the Company is promoting reductions in environmental impact, CO₂ emissions and energy consumption.

CO₂ emissions and emissions factor

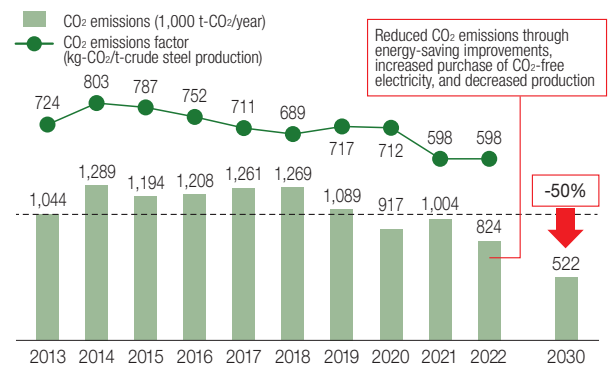

CO₂ emissions: calculated based on the CO₂ emission factors provided by contracted electric power companies for each fiscal year
Calculations are limited to Scope 1 + Scope 2 on a non-consolidated basis (derived from energy)

Fiscal 2022 emissions results are subject to third-party verification

https://www.daido.co.jp/common/pdf/pages/sustainability/data/co2_data.pdf (Japanese only)

Examples of CO₂ emissions reductions by saving energy

In order to reduce CO₂ emissions by saving energy, Daido Steel is working on detailed measures to cut energy wastage and loss in each process, as well as investing in improvements by developing oxygen combustion technology to raise heating efficiency, utilizing ceramic fibers to enhance insulation in heating furnaces, and other measures. Grassroots activities also include improvements such as using insulation materials to increase heat retention of steam pipes to cut heat loss through radiation and dispersion, and taking steps to counter air leaks at plants.

●Oxygen combustion technology

Because oxygen combustion results in high flame temperatures and the energy required to heat the combustion air can be saved, we are able to improve energy efficiency in temperature ranges above 1,000°C, which are often used at Daido Steel.

In addition to the ladle preheating equipment used in the steelmaking process, Daido Steel is expanding the application of oxygen combustion to soaking furnaces and continuous casting tundish preheating equipment.

Illustration of application in ladle preheating device used in the steelmaking process

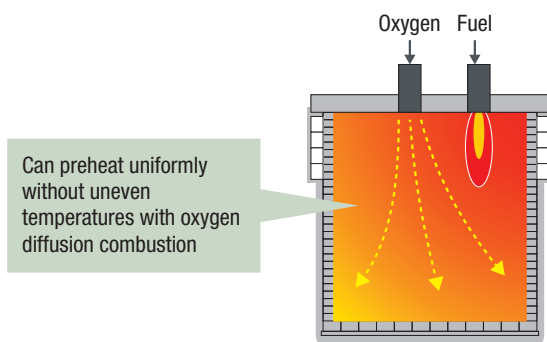

●Using ceramic fibers in heating furnace refractories

Daido Steel has more than 150 heating furnaces and heat treatment furnaces. Upgrading these facilities to use ceramic fiber, which has excellent insulating properties, results in better heat retention and greatly reduces the amount of energy used.

We are steadily expanding investment in these upgrades, starting with the heating furnaces, which consume large quantities of fuel.

Example of use in forging heating furnace at Shibukawa Plant

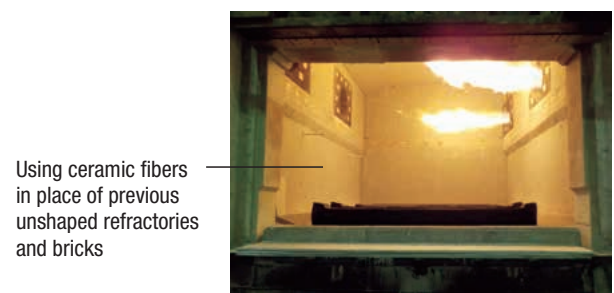

● Work to increase heat retention of steam pipes

The deterioration of steam pipe heat-retention material and sheet metal over time results in reduced heat-retentiveness and increased risk of pipe corrosion. By performing work to increase heat retention in order to suppress heat radiation, energy loss can be controlled and the lifespan of the steam pipe extended, steadily expanding the scope of application.

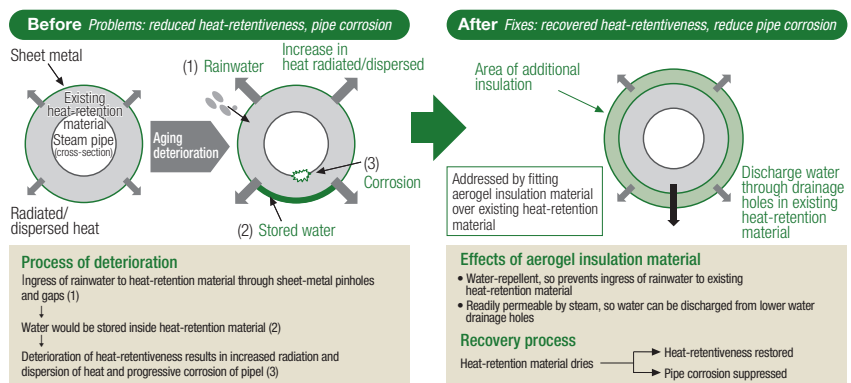

● Compressor upgrade and installation of compressor quantity control

The amount of compressed air used varies with the operational status at each production site. We have installed screw-type compressors with inverter control capable of handling minute fluctuations and compressor quantity controllers, which reduce wasted operations by enabling the automatic adjustment of compressor startup and suspension.

Image of control by installing compressor quantity control

Control method before improvement Manual

- The load is adjusted by two reciprocating compressors based on the signal from the pressure gauge
- Workers operate the startup (load of 100%) and suspension of the other seven compressors
- Adjustment of reciprocating compressors can only be performed step by step, resulting in excess supply (a)
- Workers cannot operate the compressors, resulting in excess supply (b)

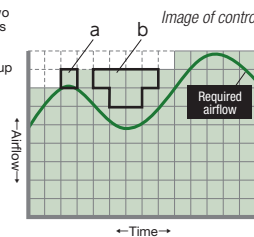

Control method after improvement Automatic

- The compressor quantity controller responds to the signal from the pressure gauge and two inverter screw air compressors adjust the airflow. It also operates the startup and suspension of the other seven compressors

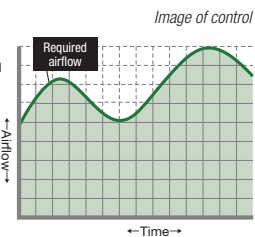

Reducing CO₂ through the use of decarbonized electric power sources

In order to decarbonize our sources of power, Daido Steel buys CO₂-free electric power. In addition, we are promoting initiatives to reduce CO₂ by installing solar power generation facilities as a way of introducing renewable energy.

● Utilizing CO₂-free electric power and promoting more widespread use in the regions

In fiscal 2021 the Company began purchasing CO₂-free electric power (annual reduction of 50,000 t-CO₂), and in fiscal 2022 this was expanded to an annual reduction of 100,000 t-CO₂. In addition to further expanding the amount purchased as we approach 2030, we will work in cooperation with Chubu Electric Power Miraiz Co., Inc. to encourage more widespread use of renewable energy in the regions.

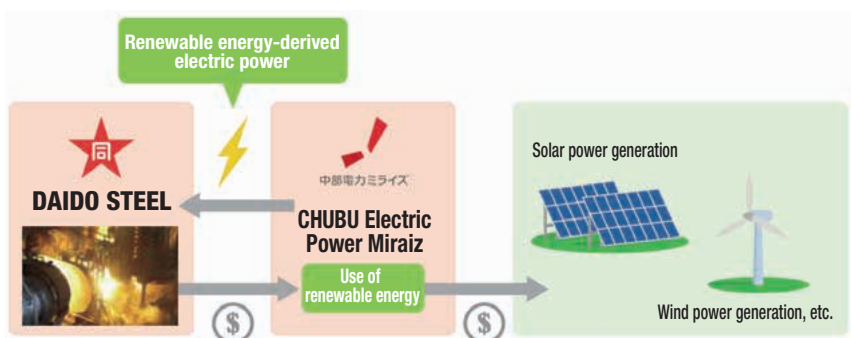

● Introduction of renewable energy

The Company began deploying solar power generation facilities at its Shibukawa Plant, with operation beginning in September 2022.

Addressing climate change

● CDP climate change and water security

Following on from the Climate Change Questionnaire we completed in the preceding fiscal year, we first submitted a response to the Water Security Questionnaire in fiscal 2022 and received a B score for both questionnaires. We are making efforts to further disclose information.

● Participation in the GX League

To achieve a carbon-neutral society by 2050 and transform the entire socioeconomic system, led by the Ministry of Economy, Trade and Industry and through the cooperation of government, industry, and academia, we are participating in the GX League, which started from this fiscal year.

Preservation of the Global Environment

Initiatives to Address Climate Change

Information disclosure based on the recommendations of the “Task Force on Climate-related Financial Disclosures (TCFD)”

1) Governance

- As an organization for investigating and deliberating basic policy, important matters, and risks and opportunities related to climate change, the previous CSR Committee was reconstituted in April 2022 as the “Sustainability Committee.” This Committee is chaired by the President & CEO, and matters deliberated and decided there are put on the agenda of the Board of Directors.
- Resolutions deliberated and passed by the Board of Directors are rolled out to individual business divisions, which reflect them in their business operations.

2) Strategy

- With the objective of understanding the impact of risks and opportunities presented to the Company by climate change, as well as considering the resilience of Daido Steel’s medium- to long-term strategy and the need for further measures, we conducted a scenario analysis for the period 2030 to 2050. For the purpose of this scenario analysis, we referred to climate change scenarios from the International Energy Agency (IEA) and the Intergovernmental Panel on Climate Change (IPCC), namely their 1.5°C and 4°C scenarios.
- As a result of verifying countermeasures to these risks and opportunities, we concluded that it is possible to enhance corporate value by developing and expanding sales of high-performance materials and innovative environmental engineering products, based on the basic strategy of the medium-term management plan for addressing changes in society as we approach decarbonization. Our assessment is that the Daido Steel strategy is resilient.

TCFD scenario analysis

Scenario	Factor	Change		Impact on Daido Steel	Countermeasures
1.5°C	Progressive shift to electric vehicles	Reduced demand for engine/exhaust system parts due to progressive shift to electric vehicles	Risk ↓	● We expect internal combustion engine vehicle-related demand to be more or less flat until 2030, but from 2030 onward we assume a significant decline as a result of the progressive shift to electric vehicles.	<input type="checkbox"/> Expand sales in future growth markets such as CASE (automotive), semiconductor-related products and clean energy to achieve sustainable business growth
		Rising demand for high-performance materials used in electric vehicles	Opportunity ↑	● Progressive shift to electric vehicles to result in rising demand for high-performance materials. Note: High-strength steel and magnetic materials used in e-Axle components, battery materials, control system parts, etc.	<input type="checkbox"/> Develop materials tailored to different product needs <input type="checkbox"/> Increase production capacity in response to rising demand <input type="checkbox"/> Launch new businesses, and launch and enter the market for new products aimed at next-generation vehicles
	Strengthening of various regulations, including those governing greenhouse gas emissions	Increase in electricity costs due to use of renewable energy	Risk ↓	● Electricity costs to rise as a result of increases in the ratio of renewable energy used.	<input type="checkbox"/> Absorb increases in electricity costs by saving energy and improving product yields <input type="checkbox"/> Introduce renewable energy within the Company itself
	Introduction of carbon pricing	Increase in operating and procurement costs	Risk ↓	● Possibility of increases in operating costs and procurement costs for alloys and other materials.	<input type="checkbox"/> Invest in reducing CO ₂ emissions and move completely to renewable energy for all electric power needs to offset cost burden <input type="checkbox"/> Request that suppliers reduce their CO ₂ emissions
		Rising demand for electric arc furnace materials	Opportunity ↑	● Due to intensifying demands for decarbonization and a strengthening trend toward low-emission products, we expect rising demand for electric arc furnace materials due to their relatively low CO ₂ emissions.	<input type="checkbox"/> Actively expand sales of low-CO ₂ emissions specialty steel manufactured in our innovative STARQ® <input type="checkbox"/> Move forward with the shift to renewable energy to promote further differentiation
	Rising demand for scrap raw materials	Increase in scrap procurement costs	Risk ↓	● Rising demand globally for electric arc furnace materials, and rising demand for high-grade scrap. ● Could be affected by soaring prices and difficulties in procurement as a result.	<input type="checkbox"/> Expand scrap recovery programs in cooperation with customers, and establish technologies to enable the use of low-grade scrap in order to control soaring prices and secure necessary scrap volumes
	Diffusion of technology to address issues related to the environment and new energy	Rising demand for innovative engineering to address environmental issues	Opportunity ↑	● As investments aimed at improving energy efficiency increase in preparation for decarbonization, demand for our environmental engineering will rise.	<input type="checkbox"/> Actively expand sales of Daido brand energy-saving products Note: STARQ®, DINCS®, ModuTherm, Premium STC® Furnace, etc. <input type="checkbox"/> Promote the development of engineering products (hydrogen-fueled industrial furnaces, etc.) that match customer needs
Rising demand for hydrogen-related technology and products		Opportunity ↑	● Rising demand for high-performance materials, such as hydrogen embrittlement resistance steel, as a result of shift toward hydrogen society. Note: High-performance materials used in hydrogen stations, fuel cell vehicles, hydrogen internal combustion engines, and other applications	<input type="checkbox"/> Develop materials tailored to different product needs <input type="checkbox"/> Acquire new customers and open up new markets	
4°C	Increasingly intense (acute) climactic damage	Risk of operations being suspended due to natural disasters on suppliers and production sites	Risk ↓	● Increasing risk of suppliers and main plants being struck by natural disasters, leading to suspension of operations.	<input type="checkbox"/> Promote BCP measure such as risk management in cooperation with suppliers and ensuring an appropriate level of inventory <input type="checkbox"/> Continue to implement flood countermeasures for main plants

3) Risk management

- As a process for managing climate-related risks, climate-related risks are analyzed, countermeasures are drafted and promoted, and progress is managed through the Sustainability Committee.
- Details of matters analyzed and considered by the Sustainability Committee reported to the Board of Directors, and management of risks is integrated across the Company as a whole.

- We conducted scenario analyses on climate-related risks, centered on the ESG Promotion and Oversight Division. After taking into account Daido Steel's business strategy, considering the likelihood of each risk and opportunity occurring and their impact in the event that they do occur, and prioritizing climate-related risks, we will focus on countermeasures to address those items with the highest impact.

4) Indicators and targets

- In order to assess and manage the impact of climate-related problems on management, Daido Steel has set reduction targets using total emissions of greenhouse gases (CO₂) as indicator.
- The Daido Carbon Neutral Challenge was announced in April 2021. The Company is promoting activities to cut CO₂ emissions with the objective of reducing 2030 CO₂ emissions by 50% over those of fiscal 2013, and of achieving carbon neutrality in 2050.

Toward 2030

Reduce CO₂ emissions by 50%
compared to FY2013

Toward 2050

Aim to achieve carbon neutrality
in line with the development of decarbonization technologies and infrastructure

2030 targets for reductions in CO₂ emissions

(Million t-CO₂/year)

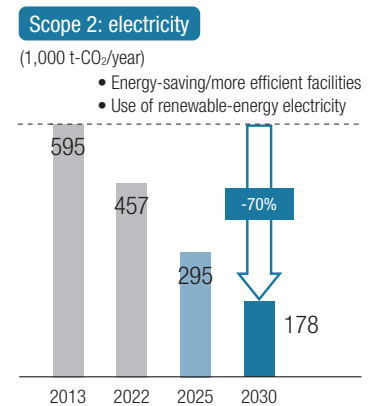
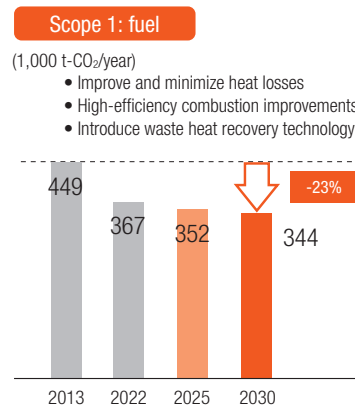
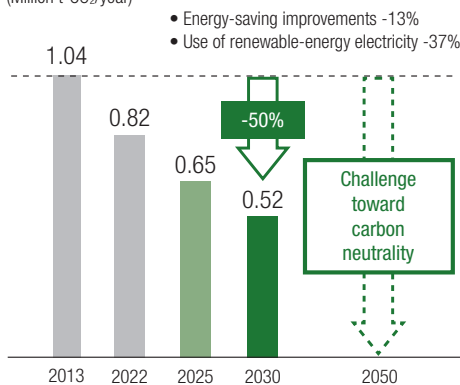

CO₂ emissions are for Daido Steel Scope 1 + Scope 2 on a non-consolidated basis (derived from energy)

Emission factors for historical CO₂ emissions (2013 and 2022) are calculated based on those provided by contracted electric power companies for each fiscal year

CO₂ emissions by Scope 3 category (1,000 t-CO₂/year)

Category	FY2022	
1. Purchased products and services	1,136	Calculated by multiplying the purchase price and purchase weight of raw materials and materials by the CO ₂ emissions factor
2. Capital goods	41	Calculated by multiplying capital investments by CO ₂ emissions factor
3. Fuel and energy-related activities not included in Scope 1 or 2	191	Calculated by multiplying purchased electricity and fuel by CO ₂ emissions factor
4. Transportation and delivery (upstream)	56	Calculated by multiplying the amount of fuel used and the amount purchased under Category 1, as reported under the Act on Rationalizing Energy Use, by CO ₂ emissions factor
5. Waste generated in operations	17	Calculated by multiplying the waste and recycling amount for each type of by-product by the CO ₂ emissions factor
6. Business travel	2	Calculated by multiplying the money spent on each mode of transportation by the CO ₂ emissions factor
7. Employee commuting	3	Calculated by multiplying the money spent on each mode of transportation by the CO ₂ emissions factor
13. Leased assets (downstream)	5	Calculated by multiplying the leased surface area by the CO ₂ emissions factor
Total	1,451	

Calculations are limited to categories applicable to Daido Steel on a non-consolidated basis

Calculation method: IDEA LCI database Ver. 3.3 (April 15, 2023) used by IDEA Lab of AIST Research Institute of Science for Safety and Sustainability, and the emission factor database for corporate GHG emissions accounting over the supply chain (Ver. 3.3) used by the Ministry of the Environment

Fiscal 2022 emissions results are subject to third-party verification

https://www.daido.co.jp/common/pdf/pages/sustainability/data/co2_data.pdf (Japanese only)

Preservation of the Global Environment

Transition to a Circular Economy

Specialty steel: The ultimate sustainable material

The mass-production and mass-consumption economy is the cause of a variety of environmental issues, including the depletion of natural resources and the destruction of biodiversity. Transitioning to a circular economy that will reuse resources in a form that will allow the realization of a sustainable society is

essential.

In order for us to enjoy the benefits of iron in perpetuity, it is important that scrap iron be reborn as various specialty steel products through electric arc furnace processes and continuously supplied to society.

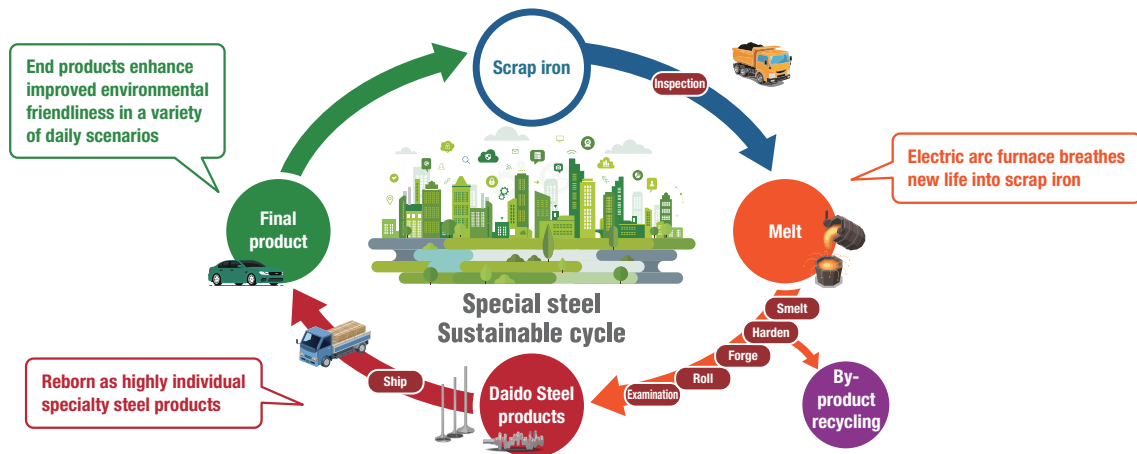

Recycling at Daido Steel

90% of the raw materials used in Daido Steel's production systems consists of recycled products, mainly scrap iron. By utilizing every last piece of iron, we will shift to a closed-loop system for iron sources.

The main types of scrap iron are market scrap produced when structures and vehicles are dismantled, process scrap originating from production sites that manufacture a variety of machinery,

and in-house scrap originating from steelmakers. The electric arc furnace processes that bring these various resources back to life as new products are, in a manner of speaking, the recycling processes that drive the circulation of iron resources. In addition, we proactively utilize recycled electrical wires and aluminum dross, RDF and RPF and so on as secondary raw materials.

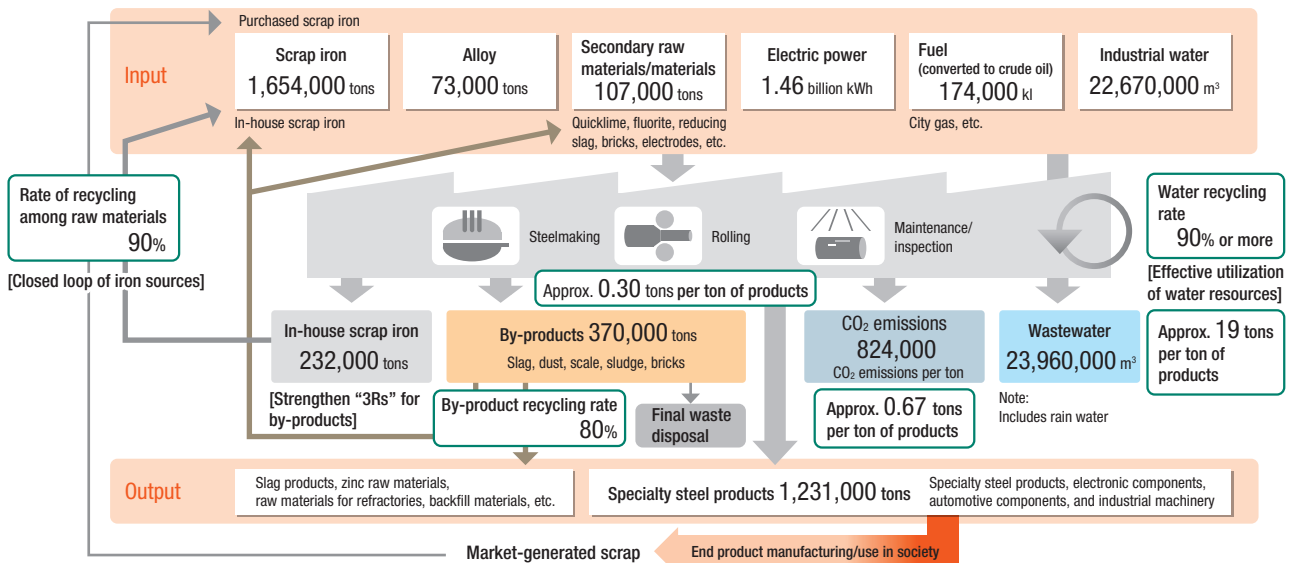

Notes: 1. Results for FY2022 (non-consolidated)
2. CO₂: Energy used in plants (Scope 1 + Scope 2) converted to CO₂ emissions per ton (using the conversion factors of the respective electric power companies)

Strengthen the 3Rs (Reduce, Reuse, Recycle) for by-products

Specialty steel manufacturing generates slag, dust, scale, and other by-products. At Daido Steel, we use our proprietary technology in an effort to promote and strengthen the 3Rs and minimize the amount of waste.

Recycling example from electric arc furnace slag

Slag generated at the Chita Plant is mainly recycled as steel slag for roads, which is roadbed material or aggregate for asphalt concrete, helping to reduce the mining of crushed stone, which is a natural resource.

Recycling example from electric arc furnace dust

Electric arc furnace dust generated at the Chita Plant undergoes melt processing at Daido Steel's proprietary recycling facilities. This is converted to zinc raw material by concentrating the zinc, of which approximately 20% is contained in electric arc furnace dust, thereby contributing to the circulation of zinc, which is a natural resource.

By-product recycling rate and landfill disposal

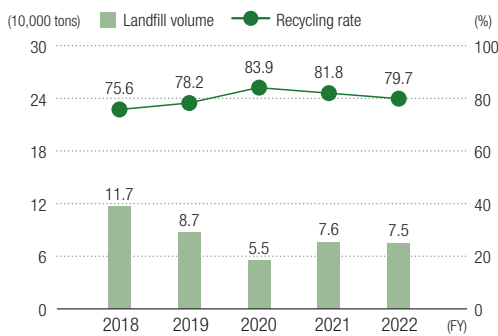

Breakdown of effectively utilized by-products

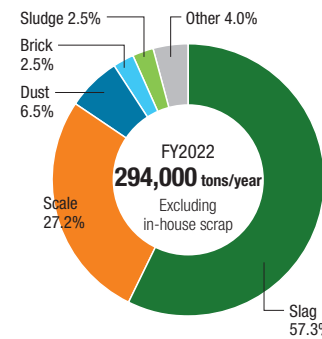

Breakdown of unused by-products

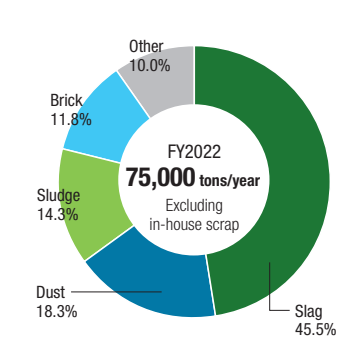

Effective utilization of water resources

Large volumes of water are used as a coolant in specialty steel processes, which involve materials at high temperatures. For indirect cooling water for facilities, whose temperature has risen due to having been exposed to high temperatures, by processing the used water appropriately, such as cooling down through permanent cooling towers, reusing it repeatedly, and minimizing discharges outside the plant, we have achieved a water recycling rate of more than 90%. Daido Steel started submitting responses to CDP questionnaires in fiscal 2022. Going forward, we will actively be working on water-related issues.

<Reference> Initiatives to prevent leakages of abnormal water
Daido Steel uses a variety of chemical substances, such as acids and alkalis. We perceive outflows of such substances from Daido Steel sites as a result of localized torrential rain and floods to be one of the water risks that we face. In order to mitigate this water risk, we have established a working group within the Company, which is promoting improvements to facilities and other initiatives.

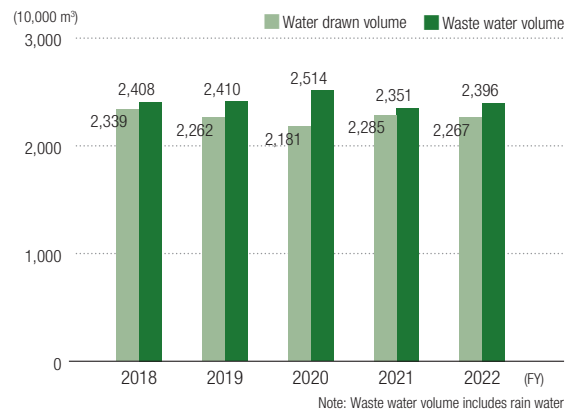
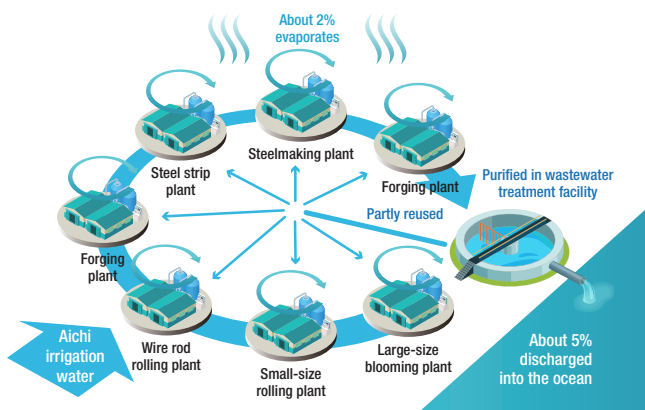

Preservation of the Global Environment

Helping to Protect the Global Environment with Daido Steel's High-performance Products and Technology

As our carbon-neutral strategy, Daido Steel continues to help establish energy transition technology, improve energy efficiency, and effectively utilize resources, and to contribute to the realization of a green society by developing and supplying “a variety of innovative products that support mobility innovation and energy transition (CN products)” and “energy-saving technology and facilities that combine engineering design and our own operational know-how (CN solutions).”

Products that support technological innovation for energy transition

* Legend Category) P: CN products S: CN solutions
 Expected sales) FY2030 sales plan and expectations compared with FY2022 is
 ↑↑: Double or more ↑: Increase of double or less →: No change

Category*	Business division	Product	Applications	Contribution to protecting the global environment	Status	Expected sales* (2030)
P	Steel/tool steel	Gear steel	e-Axle gear reducers	BEV=Expansion of zero-CO ₂ emissions	Some volume production	↑↑
		Steel for motor shafts	e-Axle gear reducers	BEV=Expansion of zero-CO ₂ emissions	Some volume production	↑↑
		Steel for hydrogen resistance	In hydrogen environments	Realization of a hydrogen society	Volume production	↑↑
		Steel for wind power generation (TPG-accredited)	Wind power generation gear reducers	Expansion of clean energy through steady operation of wind power generation	Volume production	↑
		CLEANSTAR®	Semiconductor manufacturing equipment	Improvement of semiconductor performance	Volume production	↑
	Functional products	Soft magnetic materials (strip) Permalloy	Current sensors	Extension of EV range through improved precision of detection	Volume production	↑↑
		Resistance materials (strip)	Current sensors	Extension of EV range through improved precision of detection	Some volume production	↑↑
		Materials for motor cores (strip)	xEV, motor cores for drones	Extension of range through reduced size and weight of motors	Under development	Commercialization in 2026
		High-performance SUS (strip), high-nickel materials (strip)	SOFC/SOEC	Reduction of CO ₂ emissions through methanation	Under development	From 2026
			CO ₂ recovery devices	Reduction of CO ₂ emissions, expansion of clean energy	Under development	From 2026
		Fe-Si spherical powder	Parts for converters	Improvement of xEV efficiency	Volume production	↑↑
		HTC® and LTX® 3D printer powder	Molds for die-casting	Improvement of mold life by achieving water-cooling holes in complex shapes	Volume production	↑↑
		High-performance powder for LIB	LIB for automotive/consumer batteries	Extension of EV range	Under development	Commercialization in 2026
		Soft magnetic powder	Reactors, etc.	Reduction of size and improvement of efficiency of HEV systems	Volume production	↑
	Target material STARMESH®-γ1	Touch panel (blackening layer)	Improvement of communication efficiency	Volume production	Commercialization in 2023	
	Fabricated materials	Materials for hydrogen resistance	Liquid hydrogen pumps, valves, etc.	Realization of a hydrogen society	Some volume production	From 2026
		Materials for geothermal power generation	Next-generation geothermal power generation	Expansion of clean energy by steady operation of geothermal power generation	Under development	Commercialization in 2025
		Materials for nuclear power/nuclear fusion reactors	Light water reactors, nuclear fusion reactors	Promotion of power generation with a low amount of CO ₂ emissions	Some volume production	↑↑
		Highly corrosion-resistant drill collars	Oil and gas drilling	Improvement of resource drilling efficiency	Under development	Commercialization in 2024
		Materials for eVTOL devices	eVTOL motors	Reduction of CO ₂ emissions from mobility	Under development	Commercialization in 2026
	Magnets	Specially-shaped and -oriented magnets (neodymium magnets)	Motors, sensors	Extension of EV range, conservation of heavy rare-earth elements	Under development	Commercialization in 2026
PLP (Press Less Process) High-performance magnets (neodymium magnets)		Motors, sensors	Extension of EV range, reduction of motor size	Volume production	↑↑	
SmFeN magnets		Motors	Reduction of industrial equipment motor size	Under development	↑↑	

Products and technology that contribute to improvements in energy efficiency

Category*	Business division	Product	Applications	Contribution to protecting the global environment	Status	Expected sales* (2030)
P	Steel/tool steel	Steel for high-strength springs	Automobile	Improvement in fuel consumption through reduced size and weight	Some volume production	↑
		Microalloyed steel for cold heading	Automobile	Reduction of CO ₂ emissions by omitting heat treatment	Some volume production	↑↑
		Steel for high-efficiency engines	Automobile	Improvement of fuel consumption	Volume production	→
		Hot stamp molds RDH395 and RDH406	Hot stamp mold materials	Improvement of productivity through improved wear resistance and thermal conductivity (improved lifespan)	Volume production	↑↑
		Gigapress molds RDH462 and RDH472	Extra-large die-cast mold materials	Improvement of productivity by ensuring toughness in large molds (improved lifespan)	Development completed	Commercialization in 2023
		High-performance die-cast mold RDH450	Die-cast mold materials	Reduction of repair frequency and improvement of yield rate through improved heat check resistance	Under development	Commercialization in 2024
	Functional products	STARPAS® (foil tape)	Magnetic shield sheet	Reduction of operation loss of electronic equipment	Volume production	↑↑
		Target material high purity Ni	Power semiconductor back electrode	Improvement of electricity consumption through power semiconductor installation	Volume production	↑↑
		LTX®420 3D powder for plastic molds	3D powder for plastic molds	Improvement of productivity and quality of resin parts in very large molds	Volume production	Commercialization in 2023
		Fe-Si spherical fine powder	Rectifier circuit parts	Reduction of loss through power semiconductor	Under development	Commercialization in 2026
	Fabricated materials	Aircraft jet engine shaft	Jet engines	Energy-saving through improved engine efficiency	Volume production	↑
		Engine valves for ships	Diesel engines for ships	Supports high-temperature combustion according to environmental regulations	Volume production	↑
S	Machinery	Electric arc furnaces with rotating drives (STARQ®)	Melting furnace for steel materials	Energy-saving through uniform scrap-melting technology	Volume production	↑
		Electric arc furnace equipped with scrap preheater in movable furnace top	Melting furnace for steel materials	Energy-saving through direct effective use of waste heat	Volume production	↑
		Premium STC® Furnace (2nd generation)	Annealing furnace for automotive components, etc.	Reduction of CO ₂ emissions through advanced energy-saving technology	Volume production	↑↑
		DINCS® (high-efficiency combustion system)	Energy-saving equipment for heat treatment furnaces	Energy-saving through effective use of combustion waste heat	Volume production	↑↑
		ModulTherm	Vacuum carburizing furnace for automotive components, etc.	Reduction of CO ₂ emissions through our proprietary vacuum carburizing technology	Volume production	↑
		SyncoTherm®	Vacuum carburizing furnace for automotive components, etc.	Reduction of CO ₂ emissions through our proprietary vacuum carburizing technology	Volume production	↑

Products and technology that contribute to effective utilization of resources

Category*	Business division	Product	Applications	Contribution to protecting the global environment	Status	Expected sales* (2030)
P	Steel/tool steel	Lead-free super free-cutting stainless steel	Ballpoint pen tips	Does not use regulated chemical elements	Volume production	↑
		DHW® 3D manufacturing wires	Molds	Extension of lifespan	Under development	Commercialization in 2024
		G-coat® 3D manufacturing wires, nickel-based, etc.	Aircraft and equipment for use in space development	Reduction of raw materials	Under development	Commercialization in 2024
		Low slag welding wire	Automobile undercarriages	Reduction of raw materials through thinning	Under development	Commercialization in 2024
Fabricated materials	Pump shaft	Desalination plant	Promotion of development of water resources	Volume production	↑	
S	Machinery	Next-generation sewage sludge carbonization system (ultra-high-temperature carbonizing furnace)	Recycling of sewage sludge	Utilization as an alternative to activated carbon or as soil conditioner	Under development	From 2026
		Incinerated refuse ash-melting and recycling furnace (DAP®)	Recycling of trash incineration ash	Volume reduction and utilization in roadbed material, etc.	Volume production	↑
		Daido Special Recycling Process for Dust and Slag Melting (DSM)	Recycling of electric arc furnace dust	Circulation of zinc, conversion of molten slag into resources	Volume production	↑

Responsibilities and Contributions to Society

Respect for Human Rights

Formulation of human rights policy

In February 2023, the Company formulated the Daido Steel Group Human Rights Policy based on the Daido Steel Group Management Philosophy, Corporate Code of Ethics, and the Basic Policy on Sustainability.

We understand the necessity to respect the human rights of all those affected by the Group's business activities and are committed to respecting human rights to ensure that the Daido

Steel Group Management Philosophy is put into practice and a future society in which people can live prosperously is realized. We will furthermore contribute to the realization of a society free from human rights violations and discrimination by respecting the individuality and diversity of all people and promoting the creation of workplace environments where everyone can work enthusiastically.

Provisions of the Daido Steel Group Human Rights Policy (excerpt)

- | | | |
|--|---|--|
| 1. Basis for respecting human rights and priority issues | 3. Education | 5. Remedy |
| 2. Scope | 4. Implementation of human rights due diligence | 6. Consultation and dialogue with stakeholders |

The full text of the Daido Steel Group Human Rights Policy is available on our website.

https://www.daido.co.jp/en/common/pdf/pages/sustainability/policy_human.pdf

Daido Steel Group Human Rights Policy Priority Issues

The following key challenges pertaining to human rights have been set out in the Daido Steel Group Human Rights Policy Priority Issues in the promotion of initiatives to respect human rights based on the human rights policy.

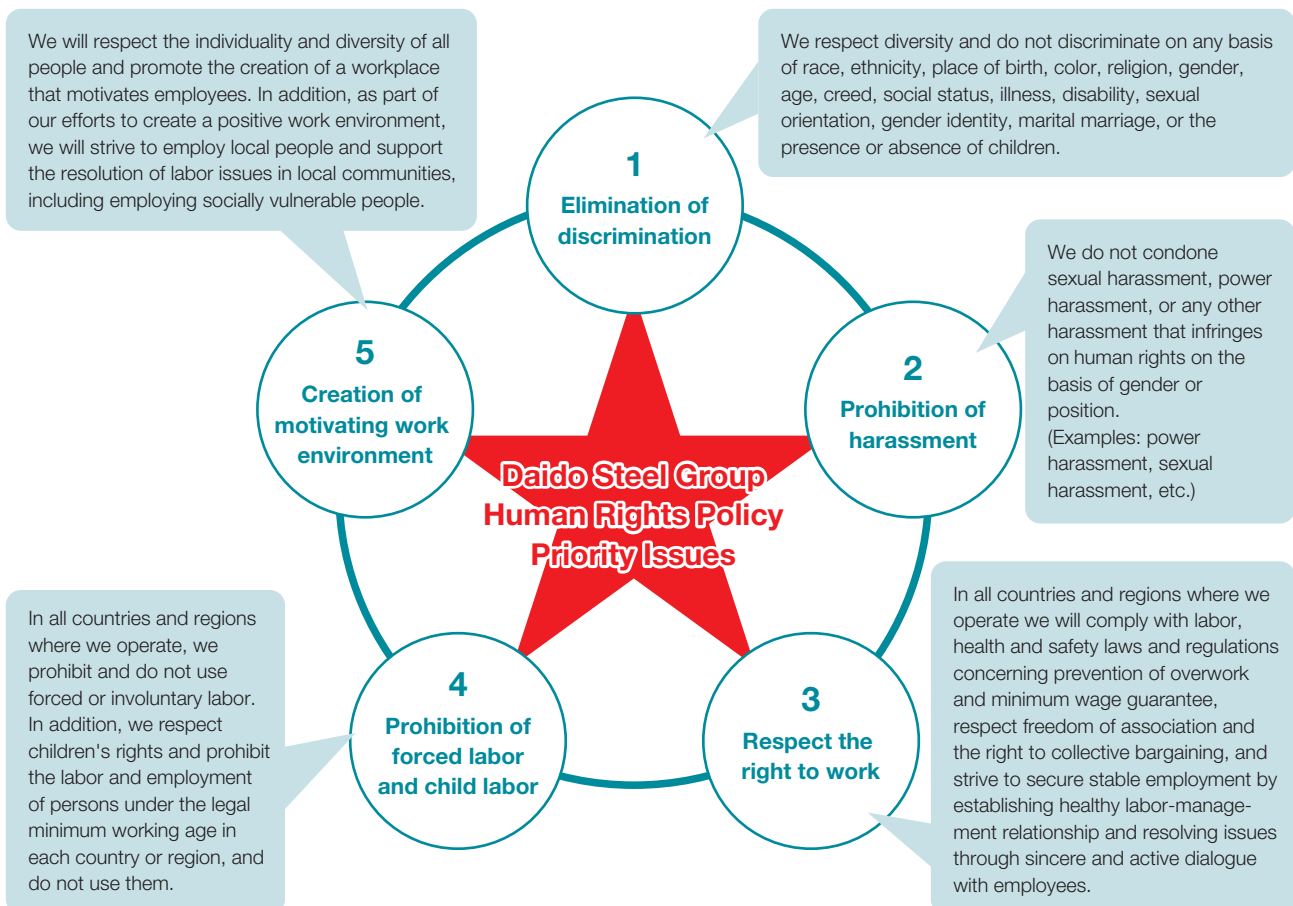

Implementation of education on human rights

The Company conducted human rights education for officers and all employees from April to September 2023. We will acquire the necessary knowledge of international norms and global trends pertaining to "business and human rights" and deepen our understanding of the Daido Steel Group Human Rights Policy to promote initiatives for the integral respect of human rights by the Group as a whole. In addition, we are implementing awareness-raising activities through the inclusion of notices in internal newsletters.



Daido Steel Group Human Rights Policy educational materials

Forthcoming initiatives

We will implement workplace questionnaires for Daido Steel employees regarding human rights, as a means to investigate the realities of negative impacts as part of our human rights due diligence (HRDD). The Company subsequently intends to seek to identify and evaluate negative impacts and consider appropriate corrective and preventive measures using a risk-based approach. We will continue to actively implement and promote these measures in fiscal 2024 and onwards.

Each Daido Steel Group company also works together with us to promote education for officers/employees and human rights due diligence, in addition to issuing notifications on the human rights policy. We will continue to provide the necessary support to ensure that initiatives for the respect of human rights are thoroughly implemented in cooperation with other Group companies.

In addition, we disseminate and provide explanations of the Company's human rights policy to suppliers, and have also initiated a survey questionnaire on human rights. Going forward, we will continue to actively encourage our business partners to achieve an understanding of and cooperate with our human rights policy.

We are meanwhile also currently taking steps to put in place the infrastructure for remedial measures such as those designed to improve our hotline system and to facilitate our becoming members of outside platforms.

Roadmap

Action	FY2023				FY2024				
	1Q	2Q	3Q	4Q	1Q	2Q	3Q	4Q	
Enhancement and revision of HRDD Remedy	Human rights education	▶			▶				
	Workplace questionnaires		▶			▶			
	Identification and evaluation of negative impacts			▶				▶	
	Implementation of corrective and preventive measures	Implementation for identified negative impacts (as and when the needs of a case dictate) ▶							
Supply chain management	▶ Implementation of questionnaires		▶ Feedback		▶ Questionnaires		▶ Feedback		
Monitoring					▶				
Hotline improvement Consider participation in outside organizations	Improvement activities as and when required Consideration of outside organizations ▶								

Examples of responses to priority issues – Harassment elimination activities

Activities to eliminate harassment were commenced from fiscal 2020. We implemented in-person, e-learning, and remote harassment education for division heads, with 160 participants in fiscal 2022.

Going forward, we will actively implement awareness-raising activities for employees other than division heads as well as follow-up for those who have already taken courses, particularly

aimed at steadily promoting the priority issues of "prohibition of harassment" and "creation of motivating work environment."

The Daido Steel Group also recognizes harassment as a problem concerning the entire Group, and supports awareness-raising activities and education for Group companies. In fiscal 2022, in-person education was conducted for 521 people from four Group companies.

UNGC signatory and GCNJ membership

In July 2023, we signed up to and endorsed the United Nations Global Compact (UNGC), a global initiative advocated by the United Nations to realize sustainable growth, while also becoming a member of the Global Compact Network Japan (GCNJ), an organization that carries out the UNGC's principles and mission in Japan.

The UNGC is the world's largest sustainability initiative, as part of which the United Nations and the private sector (companies and organizations) join forces to build a healthy and robust global

society.

The Daido Steel Group endorses the ten principles in the four areas of Human Rights, Labour, Environment, and Anti-Corruption advocated by the UNGC, and will actively promote initiatives towards their realization.



Responsibilities and Contributions to Society

Elimination of Occupational Accidents

Basic approach

No management results can make up for occupational accidents. "Safety and health are the source of happiness," and "the foundation of corporate management." Based on the principle of "Safety takes precedence over everything," we establish working

environments enabling everyone working in the Group, including elderly and women, to work safely with peace of mind and conduct activities to eliminate occupational accidents.

Safety Management Policy and targets

Company-wide Safety Management Policy

1. Rebuilding a safety education system within the workplace ...Enhancement of safety sensitivity through small group activity
2. Safety education providing an understanding of the hazards in the workplace ...Promotion of steady OJT in the workplace
3. Creation of systems for risk identification ...Risk assessment promotion 3-year plan, essential improvement of facilities, risk-sharing/reduction
4. Strengthening of construction management

Targets

Serious accidents: zero

Ratio of lost-time work injuries: ≤ 0.2

Safety management organization

We have established a safety management system headed by the President, with safety messages from the President disseminated throughout the Company. In addition, the Safety and Health Committee and labor and management are working as one to monitor and appropriately handle actual safety

conditions.

Information is also shared across the Group through safety meetings with Group companies, with the Daido Steel Group continuing to work as a unified whole.

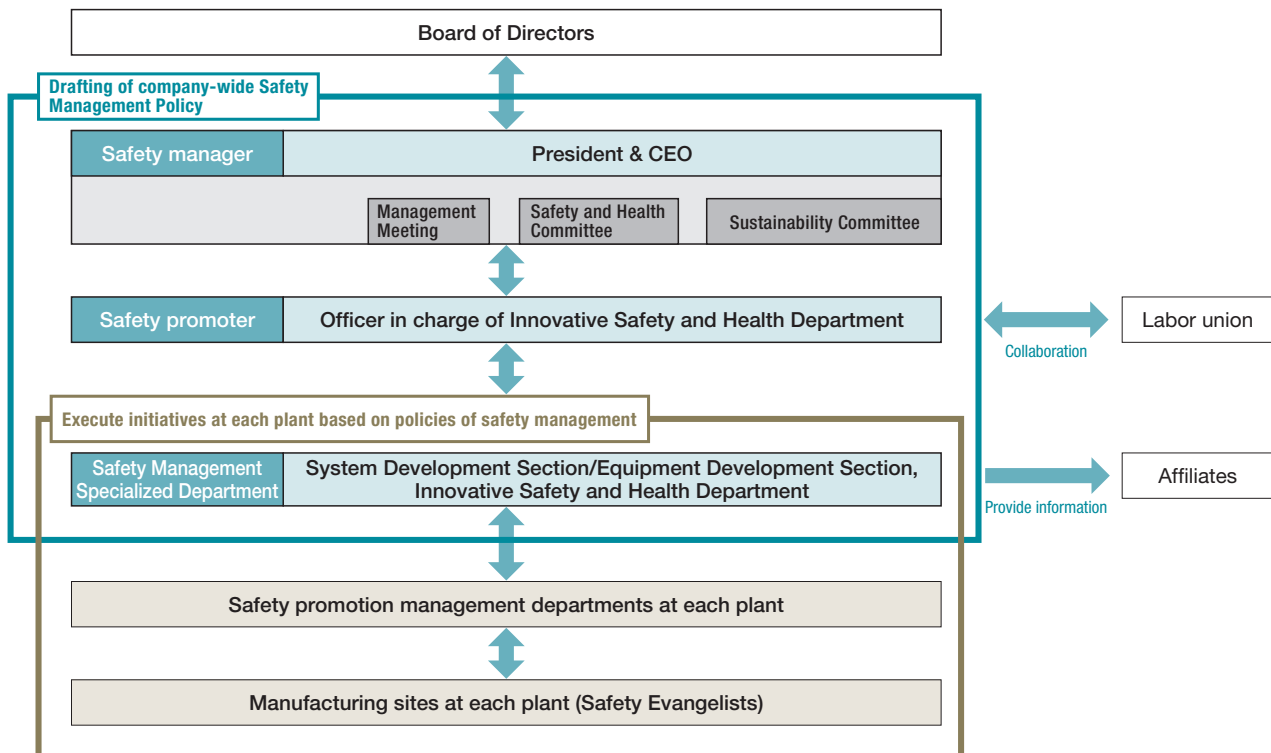

Safety performance

The rate of lost-time work injuries in the manufacturing industry is lower than the average level for all industries, and the steel industry is particularly low.

Nevertheless, in 2022, following a major deterioration in the Company's performance in recent years, in addition to implementing "workplace safety education and securing of a framework for activity" and "safety education for understanding hazards in the workplace" to heighten safety sensitivity especially among early career employees, we initiated a 3-year plan for promotion of risk assessment as "the creation of a framework for identifying risks," and are currently promoting risk sharing.

Ratio of lost-time work injuries

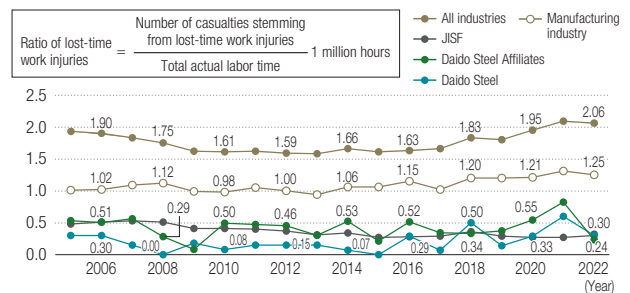

Status of specific activities

Following the drafting and approval of company-wide policy, annual plans are drafted at each plant, with reports on progress and results shared through monthly safety patrols of each plant and in regular meetings such as the company-wide Safety and Health Committee and the company-wide Plant Manager Meeting. Audit & Supervisory Committee members and Company officers also attend important meetings to work toward achieving thorough safety management at each plant at the management level.

Furthermore, Team Leaders Meetings are held four times a year for the purpose of sharing information on a workplace level

with each safety management department and to ensure shared mindsets regarding safety activities. We are meanwhile also striving to establish detailed understandings of workplaces by means of individual interviews in an effort to prevent accidents.

Safety study sessions with affiliates, at which topics for discussion are brought up, are held several times a year, with problems and safety challenges as part of work processes shared and countermeasures discussed.

With regard to overseas plants, we plan to establish shared activities themes and implement on-site communication on safety.

Education system for improving safety sensitivity

● Safety Evangelist activities

Safety trainers/leaders (74 Safety Evangelists companywide) are assigned to each workplace. Safety Evangelists are personnel who are well-versed in general tasks as well as hazards and risks within the workplace, and provide on-site, in-situ, and timely guidance to employees to improve their sensitivity to danger.



● 3-year plan for promotion of risk assessment

In 2022, our main focus of initiatives was education. In 2023, activities are focused on identifying and sharing risks at each workplace.



Legal compliance/creation of safety management system

● Risk assessment of chemical substances

We are rolling out information sharing and educational activities alongside each plant toward the achievement of their autonomous management.

● Creation of safety management system

We are focusing our efforts on infrastructure building toward the operation of the OSHMS*.

* Occupational safety and health management system

Essential improvement of facilities safety

● Reduction of risks during slinging operations when operating cranes

We are making efforts to reduce the risks associated with slinging operations by cranes, where the chance of a serious accident occurring is particularly high.

[Overview of improvements]

There are inevitable difficulties involved in placing oneself at a distance from a suspended load during removal of a sling suspension from a crane hook.

We developed a device for automated opening and closing of the hooks to reduce the risk of operations involving the inability to move away from a hazard source.

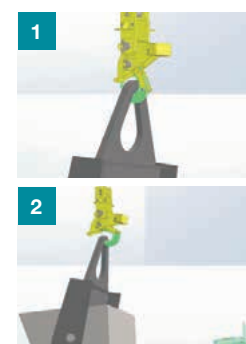

Hook closes when the bag is lifted

Hook opens when the bag is lowered

Responsibilities and Contributions to Society



Promotion of Health and Productivity Management

Basic approach

We will proclaim our commitment to building a company where employees work with vigor and motivation based on an awareness in our Health and Productivity Management Declaration that “safety and health are the source of happiness,” and that “human resources are the most valuable of a company’s resources,” seeking to increase the number of employees working enthusiastically and determinedly while actively pursuing increased productivity and the creation of corporate value for the organization as a whole through health and productivity management.

Health and productivity management organization

Under a system with the President as its head, Health and Productivity Management Promoter and the Health Management Specialized Department formulate a company-wide policy, and in coordination with the health insurance association and labor union, implement measures at each plant and share information with Group companies.

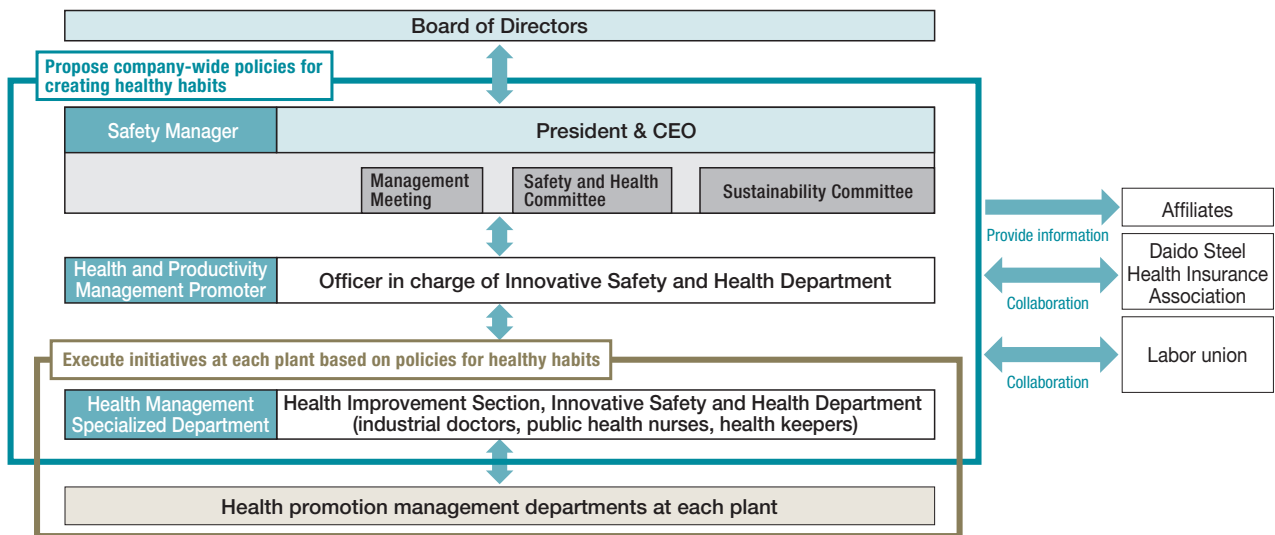

Medium- to long-term health and productivity management policy: “Four pillars”

The Company has positioned “four pillars” as part of its medium- to long-term health and productivity management policy, indicating its behavioral targets for employees by respective pillar.

<p>Mental</p> <p>We promote activities to stand by employees and their families to protect mental health.</p>	<p>Infectious disease prevention Disease prevention</p> <p>Basics of infectious disease prevention measures Hand washing/ coughing etiquette</p> <p>We will actively promote activities for early detection and treatment of serious illness.</p>	<p>Physical</p> <p>We aim to establish suitable exercise and diet for healthy lifestyles.</p>	<p>Prevention of passive smoking</p> <p>We promote smoking areas and quitting smoking to reduce smoking's harm on health.</p>
<p>Healthy behaviors target</p>	<p>Healthy behaviors target</p>	<p>Healthy behaviors target</p>	<p>Healthy behaviors target</p>
<p>Build an open and pleasant working environment</p>	<p>Improve health screening results</p>	<p>Maintain an appropriate body weight</p>	<p>Smoking cessation challenge</p>
<p>Bidirectional and enhanced communication skills, improved work-life balance</p>	<p>Health as the source of happiness, improve health literacy and prevent serious illness</p>	<p>Physical fitness for extension of the retirement age and of healthy life expectancy for a happy life in an era of 100-year lifespans</p>	<p>Prevent secondary health hazards from exhaled smoke among smokers and non-smokers (smoke-free premises), support for smoking cessation</p>

Health and productivity management strategies map and KPIs

Based on the “four pillars” we have formulated strategies for improving well-being and are promoting measures toward the achievement of a Daido Steel where employees work with vigor and motivation.

Challenges identified from the fiscal 2022 analysis	(1) Those who lack mental and physical vitality are more likely to experience challenges in their workplace environments and to suffer from non-specific complaints	(2) There is a higher incidence rate on statutory items than nationwide values
KPI	(1) An increase in the proportion of those able to perform their work duties in a state of full mental and physical vitality Actual value of 35% → Target of 50% or greater	(2) Reduce incidence rates Actual value of 70% → Target of 55% or lower

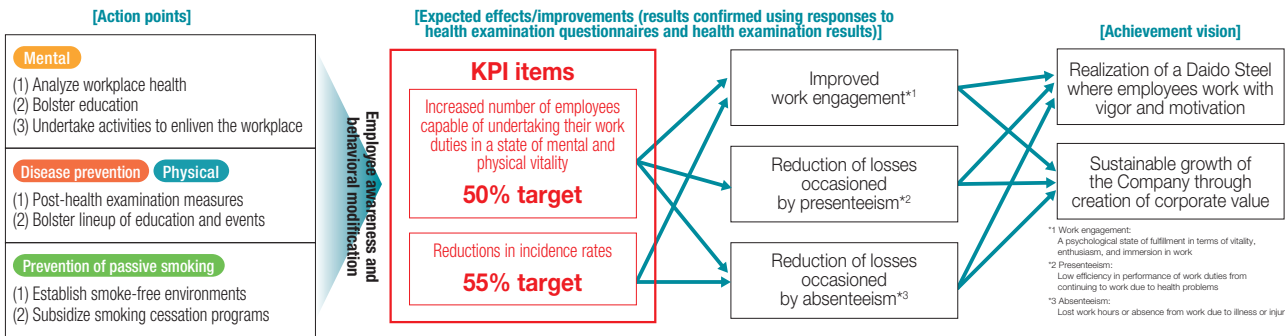

KPI trends

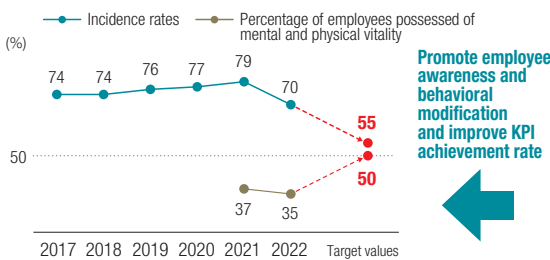

	FY2021 performance	FY2022 performance
Ratio of those undergoing health examinations	100.0%	100.0%
Ratio of those undertaking stress check-ups	99.9%	99.8%
Ratio of persons with high levels of stress	7.7%	7.4%
Ratio of persons well rested from getting a sufficient amount of sleep	74.6%	72.1%
Ratio of smokers	26.9%	26.7%
Ratio of persons eligible for specific health guidance	18.6%	18.8%
Ratio of repeat examination uptake by persons requiring detailed examinations	98.2%	98.9%

Outcomes of health-related initiatives

Mental	<ul style="list-style-type: none"> E-learning on mental health for managers and supervisors: 96% of managers and supervisors attended the course and passed a comprehension test Implementation of EAP trial counseling (Chita Plant, Corporate Research & Development Center, others) Regular hosting of workshops on enlivening workplaces by outside speakers for the “Making a company that people look forward to working at every day” project
Disease prevention	<ul style="list-style-type: none"> Interviews with occupational health staff after health examinations: 99.97% implementation rate in fiscal 2022; commencement of Individual Health Declaration, to record and keep to hand healthy behavioral targets Delivered education program of workplace lectures by dispatched public health nurses: Employee participation rate of 50% in fiscal 2022 Health follow-up for employees on overseas postings (pre-departure vaccinations, health examinations on homecoming, etc.) Recommendations to undergo examinations, including requests from bosses, for those requiring detailed examinations
Physical	<ul style="list-style-type: none"> Physical functionality measurements at each plant and follow-up guidance for those with poor levels of fitness Regular provision of healthy menu options and salads at employee cafeterias Promotional events for consumption of vegetables using the VegeCheck device Walking events hosted by each plant; implementation of body composition measurement sessions
Prevention of passive smoking	<ul style="list-style-type: none"> April 2024: Expansion of the scope of no-smoking hours toward achievement of company-wide no-smoking during regular work hours Co-sponsoring by health insurance association of online smoking cessation programs and provision of cost subsidies

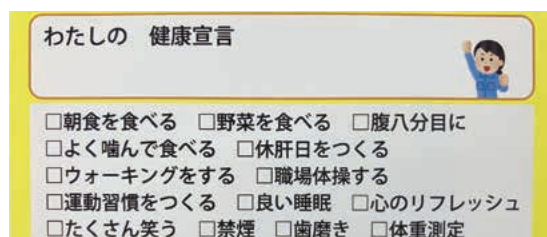

Individual Health Declaration card

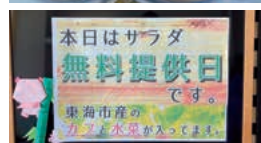

Free provision of salads at Chita Plant



VegeCheck event

Note: VegeCheck is a registered trademark of Kagome Co., Ltd.

Responsibilities and Contributions to Society

Promotion of Diversity

Initiatives to promote diversity

We believe that an important factor in building a foundation for diversity management is the dual pillars of a climate characterized by a high level of mutual acceptance and a state in which each individual can tap into their capabilities, which foster a lively workplace environment. This will mean that each employee, regardless of their age, gender, personal values, sexual orientation, disability, their lifestyle/personality, and other factors, can persist in their work with a sense of fulfillment and satisfaction, while respecting one another's differences. This is the driving force behind manufacturing at the Company. To make this a reality, we are pursuing initiatives to encourage active roles for women, further

enliven the workplace and the entire Company, and bring about transformations in awareness and the culture in order to ensure that each individual can continue to unleash their full potential.

3 steps of diversity promotion

Activities started in fiscal 2014 have proceeded from STEP 1 to STEP 2. The goal of STEP 2 is to utilize and promote diversity. This involves implementing initiatives that enliven the workplace and team dynamics at the organizational level, while also addressing the competencies and career development of individuals.



Support for the creation of job satisfaction—Job satisfaction awareness surveys

Job satisfaction awareness surveys have been conducted for all employees since fiscal 2020 with the aim of creating job satisfaction for each individual and enlivening the workplace. The outcomes of these surveys have brought to light challenges such as “communication gaps” with their origins in differences in values between generations (generation gaps); a “reduced sense of unity in the workplace” caused by drastic environmental changes; and “insufficient management skills to cater to changing times.” In response to these challenges, initiatives such as the Management Training for Section Managers and Workplace Enlivenment Project were launched in fiscal 2021.

Curriculum (3-step)	Number of times held	Total number of participants
STEP 1 Motivating subordinates	12	162
STEP 2 Achieving a balance between systematic training and education and sustained results	11	142
STEP 3 Methodologies to cater to and train a diverse workforce	Planned implementation in FY2023	

“Making a company that people look forward to working at every day” project

We launched a pilot workplace initiative in fiscal 2021 which is currently ongoing as part of efforts to support the enlivenment of workplaces. Based on the principle of “participation by all, with focused efforts on feasible changes within current resources, without negativity or criticism,” all members are working together to envision a workplace one can “look forward to working at every day.” The ultimate aim of this initiative is to inspire each individual to undertake behaviors conducive to this vision and for “the workplace to evolve autonomously.”

At present, a gradual deepening of mutual understanding is being facilitated through this process whereby early career and experienced staff members share their concerns, feelings, and ideas about the workplace together. Going forward, we are committed to actively continuing our activities, with care and attention to each and every process.



Management Training for Section Managers and 360-Degree Evaluation

We implement training and education to further enhance the management skills of the section managers, who are key to the enlivenment of the workplace. Specifically, the training curriculum incorporates short interviews with subordinates; concrete feedback on work duties; instruction in how to communicate and deepen relationships of trust with office staff members while drawing out individual capabilities and improving team dynamics, by means of the three steps indicated in the table to the right.

In fiscal 2022, a 360-Degree Evaluation for management-level staff was also introduced, with the aim of facilitating the acquisition and consolidation of flexible management skills. The Job Satisfaction Awareness Surveys and the 360-Degree Evaluation are designed to deepen understanding of organizational evaluation (team dynamics) and individual management skills, respectively, based on objective data.

Encouragement of active roles for women and career development

Introduction of management system for shortened working hours

In the context of the increased numbers of employees with diverse working styles, a management system for shortened working hours was introduced in April 2023. This system aims to facilitate career development for the next generation of managers who will work shorter hours. The goals of this system are to provide opportunities from an early stage to develop the skills required to undertake management positions in the future, thereby facilitating employees with the capabilities and motivation to do so to broaden their activities domains.

Implementation of individual interviews

Employees certified as career consultants and industrial counselors have since fiscal 2018 conducted scheduled individual interviews with all female employees at the Company, with the aim of identifying career fulfillment and training and development issues. For female global staff in particular, we arrange both individual interviews and interviews with their

supervisors, in order to build career steps and expand professional domains in a manner tailored to their capabilities and individual characters, while also seeking to share and find solutions to their concerns about workstyles during life events, with all of this designed to feed through to the development of the next generation of managers.

Expanding duties domains and capacity building for area staff

Area staff play a vital role in bolstering the foundations of the workplace, and the Company thus provides them with various training program aimed at helping them to manifest their potential for the roles they can be expected to fulfill at an early stage. The selective training initiated in 2017 expands the scope of duties domains by leveraging experience, and offers training and development as personnel who will comprise the rear units to support teams. This latter will involve, for example, learning the skills of immersion and involvement and conceptualization as well as perspectives of holistic optimization. Area staff who have completed selective training are now playing an active part as role models for these skills.

Testimonials from selective training course participants



Tomomi Fujita,
Head Office Director's Departmental Section

This training taught me that I can do work that contributes to the Company depending on how I use my time from day to day. I hope to put what I have learned into action to become a superlative area staff member capable of playing a key role at my workplace and moreover at the Company.



Misato Yasui,
Large Bar Rolling Section, Chita Plant

The training fostered my awareness of ingrained perspectives, attitudes, and ways of communicating, to transform my relationships with staff at my workplace. I will be proactive in my efforts to continually strive to nurture a mindset and behaviors which create an atmosphere of mutual approachability and becoming a reliable presence for others.

Towards the active participation of diverse personnel

Promotion of understanding of LGBTQ community

The Company is furthering initiatives to promote understanding of LGBTQ community aimed at creating a culture of understanding and acceptance of diversity. By providing e-learning and incorporating LGBTQ topics into "Fureai DAIDO" (an internal newsletter) and harassment training aimed at different tiers, we are implementing initiatives to nurture an understanding of these topics among all employees. Going forward, we will establish a consultation service, prepare a first response manual for those responsible at respective offices and plants serving as consultation contact points, and promote education and other measures, to actively create a climate in which the employees working there can feel more secure.

Support for senior personnel

In April 2023, the Company extended its retirement age to 65. With this change, and in anticipation of changes in the roles they will be expected to play, we have launched career training focused on employees in their 50s, as a prompt to achieve career autonomy and restructure their careers. Through these

efforts, we aim to make a reality of an organization at which each individual is facilitated in proactively envisioning their career after their roles have changed or following retirement, and thereby allow them to continue to play an active role.

Promotion of employment of people with disabilities

The Company is also pursuing initiatives for the promotion of the employment of people with disabilities, with the aim of creating workplace environments at which a diverse workforce can work comfortably.

Rate of employment of people with disabilities (%)

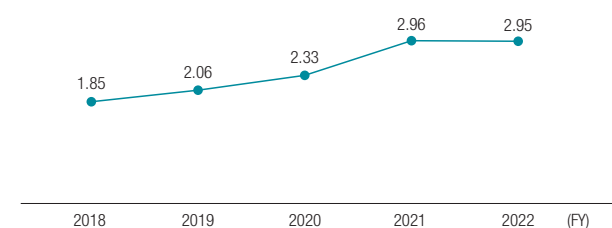

Promotion of Diversity

Education for employees

The Company has instituted a human resource development policy of “promoting employee autonomy and developing human resources who will learn (grow) autonomously with high aspirations and persist in their challenges,” with the aim of developing human resources that will put the Conduct Guidelines into practice and realize the Management Philosophy. We conduct training and education for employees which is based on our expectations for each grade, as well as knowledge and skills acquired off-the-job, which are summarized in the skills development guidebook. The education and training system is comprised of global staff education and expert education courses.

Recruit & Education (RE) activities

We consider the continuities from recruitment to the assignment and training of early career employees to be important in ensuring that each and every employee can give expression to their full character and capabilities. We have structured and instituted the companywide mechanism of Recruit & Education (RE), with each subcommittee taking the lead in consistent activities which encompass all processes from recruitment to human resources development. RE committee members are meticulously selected from among division heads at the section to which new recruits are to be assigned, with a chairperson also selected for each subcommittee. In fiscal 2022, two humanities subcommittees and two science subcommittees met to discuss assignments and training and education plans emphasizing the individual capabilities of early career employees.

Global staff course training and education

The environment in which companies operate is currently subject to dramatic day-to-day changes, which is also resulting in a diversification of the skills and expertise required of each and every employee, and rendering the necessity to be adaptable to change more essential than ever before. To cater to these changes, it is vital that each and every individual develop the capacity to undertake autonomous decisions and actions and constantly develop their abilities. The Company provides various training and education to instill in employees the motivation to grow autonomously.

By conducting off-the-job training in online formats and making it more efficient, we are facilitating into increased time dedicated to training and education. Currently, about 70% of all training is conducted through online education.

Time investment in global staff training

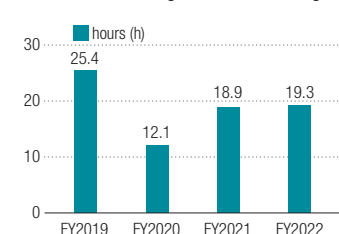

Use of domestic and overseas study programs, and outside training

The Company arranges placements of employees to study at

universities in Japan to improve skills, which includes obtaining qualifications and degrees, and also extends to research on cutting-edge technologies. We also arrange study abroad and overseas trainee placements with a focus on those in their early careers, as part of our efforts to improve individual capabilities and develop global human resources.

We furthermore actively utilize outside training with objectives including the fostering of the mindset of looking beyond the company and development of the core personnel who will be responsible for management in the future.

Number of dispatch employees (persons/year)

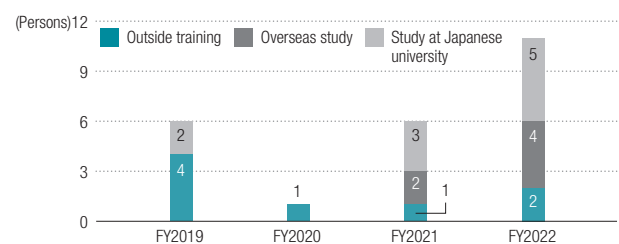

Expert course education (Daido Steel Technical Training School)

The Technology Training School is foundational to nurturing manufacturing capabilities, which is one of the Company's core competencies. Daido Steel Technical Training School commenced activities in 1940 as the Technician Training School and has existed in its current form since 1952, since when it has supported the training of expert (technical) employees over a period of more than 80 years.

Training times at Daido Steel Technical Training School (hours/year)

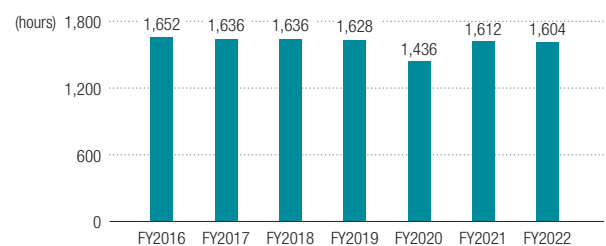

Currently, new recruits from senior high schools are given approximately 10 months to acquire the skills they will need in the workplace. This includes mental preparation for life as a working adult and as an employee at a corporation as well as support for living on their own, and extends to training on safety, specialty steel production, mechanical and electrical maintenance, and skills training. Following this, these new recruits are assigned to a specialty steel production site. In this way, we aim to develop highly motivated and active human resources capable of deepening their knowledge of the characteristics of specialty steels and to teach them how the specialty steels they manufacture enrich people's lives.

A diagram of the Company's employee training system is available at our website.



<https://www.daido.co.jp/sustainability/employee/employee/index.html> (Japanese only)

Work Style Reforms

Work style reforms

Daido Steel promotes work style reforms aimed at enabling diverse personnel to make the most effective use of their time and location, and exercise their capabilities to their maximum. We also believe that such work style reforms will serve to enhance our business continuity functions and improve the productivity of staff. Prompted by our responses to the COVID-19 pandemic, the Company undertook the creation of the infrastructure for work-from-anywhere environments, including those for remote work and the introduction of satellite offices. We have thereby both enhanced our business continuity capacities and developed a foundation for improved work-life balance aligned with the needs of working people. In addition, each plant promotes initiatives to increase staff productivity including the active use of IT tools to improve operational efficiency, activities to improve the efficiency of meetings, and the transition to a paperless office environment. Head Office is additionally focusing efforts on reforming office layouts to create pleasant workplace environments.

Improving operational efficiency through the active use of IT tools

Traditionally, staff duties have entailed copious ancillary tasks, including data processing and data entry, resulting in the generation of countless man-hours. Towards a solution to this issue, system engineers are dispatched to each plant to reduce man-hours by means of the introduction of robotic process automation (RPA) for various tasks and the automation of operations by using software functionalities. These endeavors have now begun to yield outcomes, including reductions in the time taken for particular tasks from several hours to a few minutes, thereby facilitating labor savings. We additionally host RPA study groups to further advance the automation. Going forward, we will roll out demonstrated good practices to other plants to facilitate further, companywide improvements in operational efficiency.

Activities to improve the efficiency of meetings

To make meetings more efficient, we first completed a companywide review of the frequency of meetings and those

eligible or required to attend, with proactive steps then taken to institute online meeting formats. The Company furthermore formulated a unique in-house policy on hosting meetings as a means to ensure meetings can be managed efficiently in an ongoing manner. As part of this policy, we stipulated that "meeting materials be distributed at least one day in advance of the meeting," and that an overview of only the essential points in these materials be given at the meeting, with resulting improvements to make meetings more discussion-oriented. As a result of these activities, we successfully reduced the number of man-hours dedicated to meetings by around 37% companywide, when compared to the situation before this initiative began.

Companywide outcomes of improving the efficiency of meetings

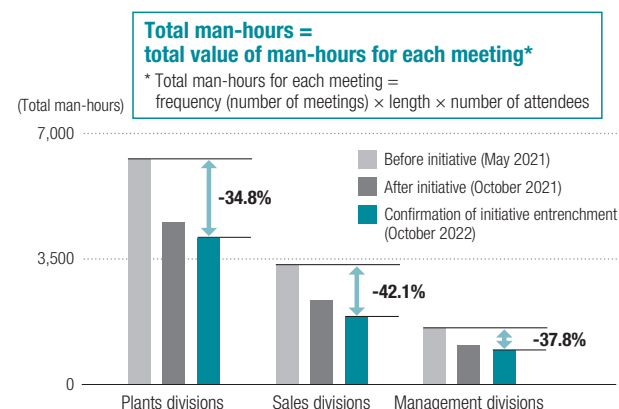

Reduction in wasted time through revisions to the rules for electronic document management

We implemented a revision to the rules for document management aimed at improving operational efficiency and facilitating effective use of data assets. For electronic documents in particular, there was an absence of uniform rules for document storage, which resulted in wasted time when searching for documents. With this, we instituted new rules for the storage of electronic documents to improve their searchability. We will continue to enhance the usability and convenience of electronic documents to actively promote paperless workflows.

Data on leave (absences) taken (non-consolidated)

The Company promotes the improvement of environments to facilitate easy access and use by employees of leave systems and other services.

	FY2018	FY2019	FY2020	FY2021	FY2022
Ratio of employees taking childcare leave (%)	10	11	9	23	32
(of which male employees)	3	3	6	18	28
Number of employees taking nursing care leave (persons)	0	0	2	0	0
(of which male employees)	0	0	2	0	0
Rate of employees using paid leave (%)	55	65	42	59	62

Responsibilities and Contributions to Society

Social Contribution Initiatives

Daido Steel has multiple manufacturing centers throughout Japan, and its corporate activities are maintained with the support of all those in these respective regions. We aim to achieve harmony with everyone in these communities through activities aligned to the region and characteristics of each plant's location, and to contribute to the realization of a sustainable society. In this endeavor, we will take as our themes regional contribution activities, sporting activity support, art and cultural activity support, and environmental preservation activities.

Activities system

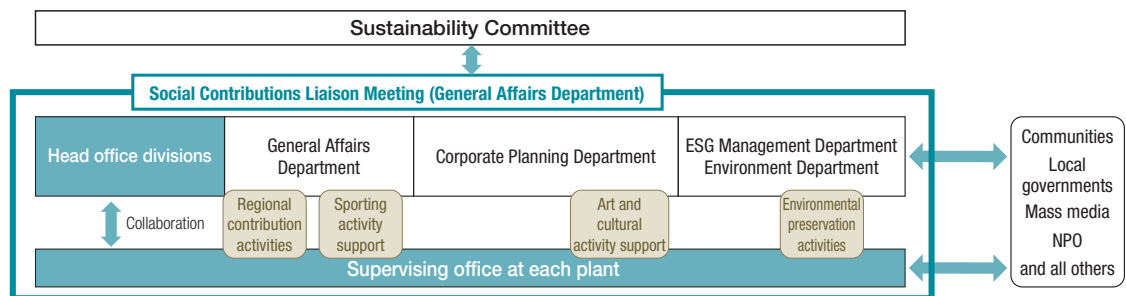

Regional contribution activities

Each of our plants is involved in close exchanges with the local authorities and residents of the communities to which they belong, aiming to communicate with them through a variety of events and activities.

In addition to festivals, cherry blossom viewing, and other mixers and events to promote mutual friendship, we will continue to play an active role as one member of these communities, and will undertake diverse initiatives including clean-up campaigns, cooperation in disaster prevention and crime prevention, and decorative public lighting displays.

Various mixers and social events

We host seasonal events and provide children with opportunities to engage in creative activities.



Hoshizaki Plant: Cherry blossom viewing party



Shibukawa Plant: Exhibition of artworks by children

Community clean-up campaigns

We conduct clean-up campaigns mainly focused on the vicinities of the plant as part of community beautification activities.



Chita Plant: Community clean-ups



Shibukawa Plant: Community clean-ups

Cooperation in disaster prevention and crime prevention

We actively implement initiatives contributing to disaster prevention and crime prevention in local communities at each of our plants.

Disaster prevention	Tsukiji Techno Center	Registered as a "Community Disaster Prevention Cooperation Office." We have concluded agreements with local authorities for the provision of materials for use in rescue efforts as well as medical supplies for use in the event of a large-scale earthquake, or damage caused by winds and flooding.
	Hoshizaki Plant gymnasium (on third floor)	Registered as a "Designated Emergency Evacuation Site (Tsunami Evacuation Building)." A primary location to which one can flee from the threat of a tsunami.
Crime prevention	Hoshizaki Plant	Registered as a "Kodomo 110-ban no ie" (children's emergency shelter)



Tsukiji Techno Center: Office buildings



Hoshizaki Plant: "Kodomo 110-ban no ie (children's emergency shelter)" sign

Decorative lighting displays

We provide scenic views and illumination for the enjoyment of residents in our vicinity as well as for drivers with year-end decorative lighting displays.



Hoshizaki Plant: Decorative lighting displays



Tsukiji Techno Center: Decorative lighting displays

Topics

Daido Steel Phenix Square (naming rights acquired)

We acquired the naming rights for Crystal-Hiroba, a section of the Sakae underground shopping center, which is one of Nagoya City, Aichi Prefecture's most popular commercial facilities, and from June 2023, named this Daido Steel Phenix Square. We will actively contribute to making SakaeChika an even more popular underground shopping center among the local community.



Sporting activity support

The Company organizes handball and volleyball classes and participates in demonstrations at various sporting events, with the main aim of contributing to the development of youth.

Our handball club (team name: Phoenix), in particular, visits elementary schools in Tokai City to give classes and makes other efforts to popularize the sport as hometown ambassadors of Tokai City.



On-demand handball classes for elementary schools in Tokai City

Art and cultural activity support

The Company sponsors a full variety of art and cultural activities. In particular, sponsoring the concerts of outstanding music performers, hosted and planned by CBC TELEVISION CO., LTD. which in fiscal 2023 is celebrating its 37th year (33rd with the Company as an exclusive sponsor), has been lauded as a program focused on youth musicians and uniquely suited to small and medium-sized halls dedicated to chamber music, where the audiences can feel as one with performers.

In fiscal 2023, we also sponsored the Noh/Kyogen play *Kimetsu no Yaiba* ("Demon Slayer") and the *Nagoya-jo Kodomo Oisen* (Nagoya Castle Children's Shogi Championship). In this way, we are supporting cultural activities in a wide range of fields.

FY2022 The concerts of outstanding music performers



Environmental preservation activities (biodiversity initiatives)

Biodiversity refers to the ways in which the numerous and diverse types of life on the planet are connected, with biodiversity loss recognized globally as being second only to climate change in terms of the most important environmental challenges we face today. In recent years, corporations have been required to incorporate biodiversity considerations into their roles, and Daido Steel currently participates in initiatives to restore biodiversity through a variety of environmental preservation activities.

Initiatives	Location	Main activities content
Hamatonbetsu Project	Hamatonbetsu-cho, Esashi-gun, Hokkaido	<ul style="list-style-type: none"> Forest conservation, regeneration activities (removal of bamboo grass, planting of broadleaved trees) Monitoring surveys (biological organisms, vegetation, etc.)
Daido Forest	Nagiso-machi, Kiso-gun, Nagano	<ul style="list-style-type: none"> Became an adoptive parent/curator for forest and carried out tree planting and other forest conservation activities
Firefly Orchard	Hoshizaki Plant premises, Daido-cho, Minami-ku, Nagoya	<ul style="list-style-type: none"> Raising fireflies on the Hoshizaki Plant premises Hosting firefly viewing parties for neighboring residents
Inochi wo Tsunagu PROJECT	Chita Peninsula, Aichi Prefecture Waterfront industrial zone Green buffer zone (green belt)	<ul style="list-style-type: none"> Installation of waterside biotopes* Establishment of animal pathways Creation of the Asagimadara Network Registered as a certified nature-friendly site

* Biotope: a habitat in which wildlife such as animals and plants can live in a stable and settled environment (biological community)

Two major biodiversity projects

Hamatonbetsu Project: an untouched forest with pristine wilderness

A designated Ramsar site wetland and migratory stopover for Whistling (Bewick's) Swans. A company-owned forest—Kutcharo Natural Forest Daido—is located on the island in the middle separating the large and small marshes, with this forest covering an area of 3.73 million square meters, which is equivalent to about 500 football courts. The Company is forwarding environmental forest restoration projects in this forest in collaboration with local environmental NPO Lake Kutcharo Eco Workers.



Scene from tree-planting activities

Inochi wo Tsunagu PROJECT: forests created by reclaiming the sea

Over 50 years have passed since the industrial complex was created along the coast of the Chita Peninsula. The green belt which is currently established in an area spanning more than a dozen kilometers in Tokai and Chita cities is referred to as the Chita Peninsula Green Belt. It consists of forests which are inhabited by a diverse range of living creatures. Inochi wo Tsunagu PROJECT is a partnership between 12 collaborating companies, including Daido Steel, alongside NPOs, local authorities, and an executive committee comprised of students, which is undertaking endeavors to improve the biodiversity of the Chita Peninsula Green Belt.



Scene of the waterside biotope

Responsibilities and Contributions to Society

Supply Chain Management

In order to fulfill its social responsibilities as a member of society at a higher level, Daido Steel is conscious of the necessity of both initiatives within the Company and throughout the entire supply chain. To achieve these, the Company recognizes that it is vital to work with business partners who understand our intentions.

Daido Steel Procurement Policy

The Daido Steel Procurement Policy defines the basic approach and stance regarding the social responsibilities we must fulfill.

It advocates for fair and equitable transactions, compliance, and respect for the environment, society, and human rights as a means to continue to deliver products and services that satisfy customers while simultaneously establishing and maintaining strong partnerships with our suppliers.

<https://www.daido.co.jp/about/procurement/policy/index.html> (Japanese only)

Initiatives to disseminate the procurement policy



* CSR questionnaires involve having respondents conduct self-evaluations of the levels of their initiatives concerning corporate governance, human rights, labor, the environment, fair corporate activities, quality and safety, information security, their supply chain, and coexistence with local communities in accordance with the procurement policy framework (fair and equitable transactions, emphasis on compliance, and responsibility as a member of society.)

FY2022 Results

The DSP system to enhance cooperation with business partners was launched in May 2022.

- (1) DSP activities questionnaires (twice annually) and feedback to business partners → Improved comprehension of DSP activities
- (2) VAVE proposals (from 105 in 2021 to 145 in 2022)
- (3) BCPs (22 new companies) to achieve tangible outcomes
- (4) Joint consideration of CN and related issues with representative business partners → Maintain considerations of Scope 3 model case planning
- (5) Introduction of Company initiatives at DSP meetings for ESG and related issues

Daido Supplier Partnership (DSP) system

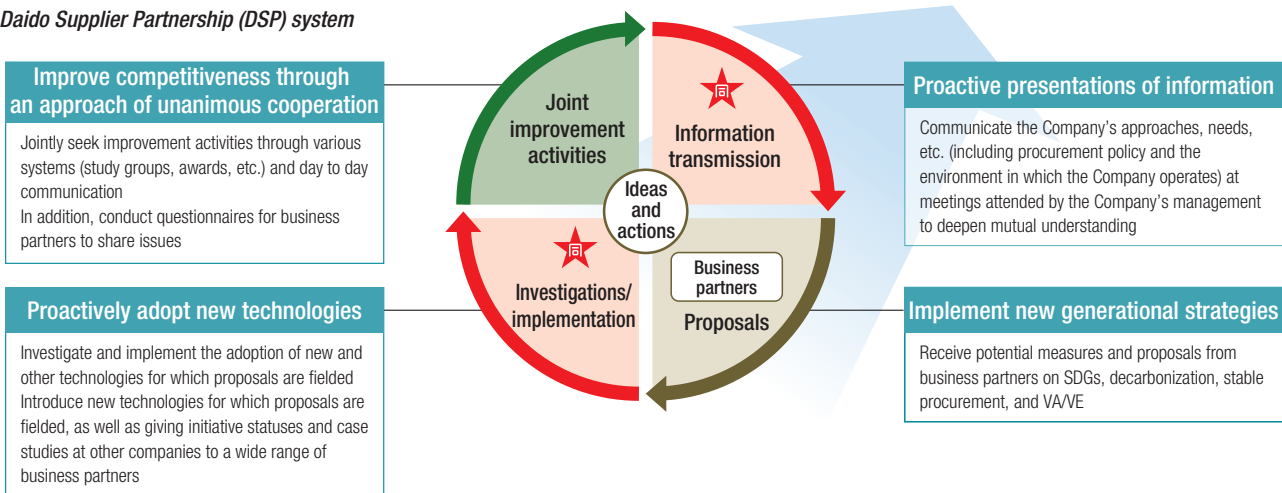

Action plan for the 2023 Medium-Term Management Plan

We will seek to cooperate with our business partners in four areas as part of the 2023 Medium-Term Management Plan.

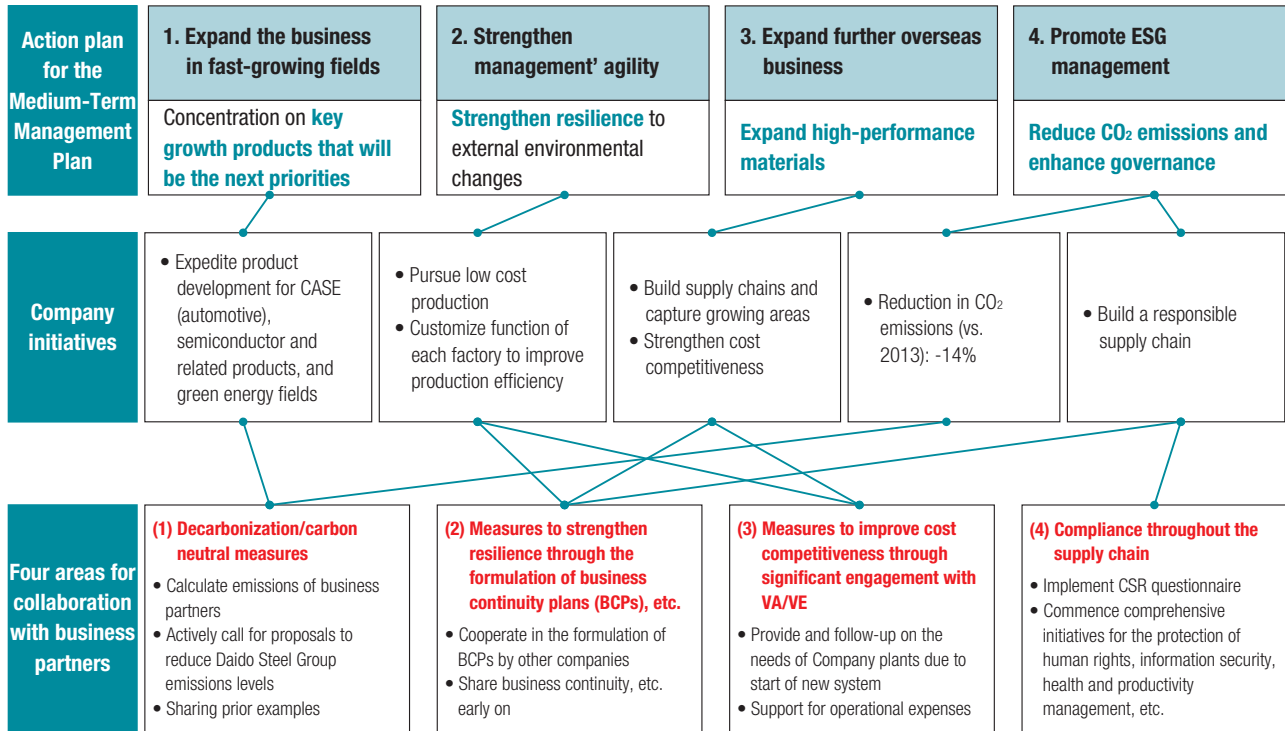

Future joint actions with business partners

Scope	Content
Carbon neutrality	Emissions and intensity calculations (Scope 1/2/3 calculations)
	Hosting of emissions calculation study sessions (sharing of calculation methodologies)
BCP	Draft BCPs/improve accuracy
VA/VE	Considerations allowing for the needs of Daido Steel plants
	Regularly communicate on VA proposals
	Support for strategy costs
Protection of human rights	In-company and supplier compliance in the respect for human rights
Compliance	Ensure thorough compliance with laws and regulations
Information security	Develop infrastructure for information management systems
Safety/health	Ensure occupational safety, promote health and productivity management



ESG lectures during DSP meetings

Responsible mineral procurement

The Company has obtained conflict-free mineral certification for the 3TGs (tantalum, tungsten, tin, and gold) and Co (cobalt) from each of our business partners to confirm that they are not conflict minerals.

In addition to obtaining conflict-free mineral certification for new sources, we also obtain information from smelting manufacturers in an effort to ensure risk-free procurement.

We are also engaged in the utilization of recycled products.

Strengthening Governance

Discussion Between Outside Directors and Chairperson of the Board of Directors,
Representative Executive Director

Towards Deepening Sustainability Management

Looking towards deepening Daido Steel's sustainability management, Chairperson Ishiguro and three outside directors had a discussion.



Ryoichi Yamamoto

Outside Director
Director of
J. FRONT RETAILING Co., Ltd.

Kenji Matsuo

Outside Director,
Audit & Supervisory
Committee Member
Meiji Yasuda Life Insurance Company
Honorary Advisor

Mutsuko Jinbo

Outside Director
Daido Educational Institutions Advisor
Graduate School of Engineering,
Mie University
Research Fellow

Takeshi Ishiguro

Chairperson of
the Board of Directors,
Representative
Executive Director

Please tell us about the governance discussion that made the biggest impression in the past year.

Yamamoto: In the past year, it was contributing to the formulation of the succession plan that left the biggest impression. I think the discussions in the succession plan formulation process were conducted exceptionally well. In selecting the new President, we were able to make our selection through an objective and highly transparent process, determining the candidates' aptitudes in writing, then spending time on discussions and deliberations in the Nominating and Remuneration Committee by interviewing the candidates. I felt my intervening value as an outside director most in the fact that the new President was selected based on the succession plan metrics.

Matsuo: I agree completely. I really want to recognize the fact that the Chairperson and the President have boldly moved initiatives forward.

Jinbo: I also felt that we put careful consideration into selecting the person at the top. I think the process of properly reaching a

result via orderly discussions and deliberations is governance working extremely well. I feel satisfied with the selection of the new President and this has left a strong impression.

Ishiguro: Personally, I think this was a year in which the Nominating and Remuneration Committee was functioning. The succession plan was too, but it was also decided to introduce a performance-linked, stock-based remuneration scheme using trusts. When introducing it, we discussed it from a variety of perspectives, and I think it has become a remuneration scheme that is also well-regarded by investors in the sense that, due to share price fluctuations, management shares shareholders' interests. This is thanks to all the outside directors.

Please tell us about your expectations for the new President and any advice for him based on your own experience.

Yamamoto: As an outside director, if I am stating the point of view

of the shareholders and taking their position, we must first achieve a PBR 1.0x or higher. The Tokyo Stock Exchange has been making serious efforts towards market reform, and there is also a demand for the disclosure and implementation of improvements to the low PBR, so I hope he will be more aware than ever of shareholders and investors and strive to improve corporate value with a sense of crisis. This is my greatest expectation.

Furthermore, my advice based on my long years of experience in top management is not to avert your eyes from the realities you don't want to see. For example, it is precisely because unprofitable businesses and impropriety are matters of concern that it is important to face them head-on. In addition, I want him to be aware of the fact that the impact of COVID-19 and other problems has changed employees' values, and to try to manage without relying on a "mindset" ideology. Finally, to speak based on my own reflections, in cases where decision-making is influenced by the surrounding atmosphere even though you do not think it is reasonable, it will not result in success, so you must devote yourself to making reasonable decisions. I want him to make decisions that will advance us toward Daido Steel's great causes, such as management philosophy and the realization of a green society.

Matsuo: I also expect a PBR over 1.0x. The new President's greatest strength is that he has a technical background, so he understands the society-wide trend of reducing CO₂ emissions. It is my great hope that he will demonstrate the management skills for further improvement in business performance in the fields of high-performance materials and magnetic materials, which drive the Company's growth. His career has focused on the development of materials, so he probably has a variety of outlooks and visions regarding current trends. For this reason, I hope that he will manage the Company with a long-term view, showing conviction and passion in deciding what he wants us to be doing in five or ten years and what we need to do to get there.

Furthermore, it is important to form an organization in which, when problems occur, reports are properly delivered to management. If reports are not delivered when problems occur, this makes things very difficult for management. I asked many company presidents who came before me for advice, and several of them told me never to reprimand staff for the content of a report, but to properly warn and reprimand them for not making a report at all. I think it's important for a company to be an organization in which management is smoothly informed of problems and issues and which can steadily discuss and implement solutions.

Jinbo: The management style of the person at the top of a university is a bit different from that at the top of a company, but I think one point both have in common is that, they should try to listen to the opinions of those around them to see if their ideas are truly correct, without being self-righteous. At the same time, I think it is necessary for them to be alone to some extent. As the times become more uncertain, the opinions of those around the President will become divided and it will become more difficult to make decisions, so he must be prepared to endure the loneliness and take responsibility for the risks when making decisions and taking the initiative.

Also, nowadays global trends and world affairs are changing with tremendous speed, and the pace of change in the industry has grown more intense. Of course it is important to develop the existing business, but I think it is also becoming more important

than ever to anticipate the needs of the next generation.

Ishiguro: In its 107-year history, Daido Steel has grown while overcoming numerous changes in the business environment. I have heard people on all sides saying they think things are going relatively well, such as results of the previous fiscal year to exceed record highs. However, the changes to social structures that come along with carbon neutrality have repercussions on resource circulation and human resources strategies, and we cannot afford to keep doing things the way they have always been done. With a technical background and no experience in manufacturing or sales, I want President Shimizu to leverage his career history, which is different from his predecessors, to advocate for the antithesis of a going concern. In addition, I hope that he will produce results such as a PBR over 1.0x and, through co-creation with stakeholders, contribute to the realization of a green society. In the selection of the President this time, the Nominating and Remuneration Committee decided on him almost unanimously. He has always thought about how to solve the issues of the customers by using the products and technology of the entire Group, and I think selecting him to head the Daido Steel Group will be good for the development of the Company, and I want to fully support him.

Please share your perception of the challenges in promoting sustainability management.

Yamamoto: I think this will become an issue for the next Medium-Term Management Plan, but we need to set milestones for the resolution of material issues. If you take a look at the current progress in areas where there are material issues, it is obscure and difficult to follow up. It would be persuasive if the Company can show how much profit we expect as a return from supplying a new product. Visualizing the 2030 supply and profit targets with specific products and technologies makes it easier for us to monitor and for our on-site employees to see how a single product can contribute to the social environment. In this way, we can instill the concept of creating shared value in the entire Company.

I think it is quite difficult to quantify the financial impact of product lineups that contribute to environment and contributions to the reduction of society's CO₂ emissions, but showing the



Discussion Between Outside Directors and Chairperson of the Board of Directors, Representative Executive Director

specific milestones for achieving KPIs, which are material issues, in the next Medium-Term Management Plan will allow us to follow up on the status of the progress.

Matsuo: As Mr. Yamamoto just said, annual management of the financial impact using KPIs is not such a difficult topic in terms of production, but when it comes to products, it also depends on how far ahead we can anticipate customers' needs, so my impression is that the hurdle is high. Nonetheless, I think we should try to communicate to customers how much CO₂ emissions they can reduce with a given product by quantifying the extent to which our product contributes to the reduction of CO₂ emissions. Being able to contribute to the reduction of CO₂ emissions in terms of both production and products can be an advantage, so I want us to strive to make that appealing to customers in specific ways.

Yamamoto: I think that, compared with Europe, both Japanese companies and consumers have quite a low sense of crisis with regard to carbon neutrality and the circular economy. This is why our initiatives are late, and in the meantime, Europe has moved forward with environmental regulations and new regulations about the disclosure of corporate information, and I feel that the discussions are preoccupied with the question of how to deal with the now-high barrier to entry. I believe that we need to comprehend the long-term structural changes and then proceed with intrinsic initiatives instead.

Jinbo: Even in R&D, I feel that there are fewer and fewer settings in which Japan is taking the lead. To compete as an equal with the West, we need to not only analyze their competing products but also to keep our eyes on the capabilities they are fostering behind the scenes. When it comes to product performance improvement, we have two approaches: one is to improve materials and the other is to change the form of the product. I want us to cultivate multilateral points of view, explore customer needs, and strive to create new value and showcase its contribution.

Ishiguro: Some of the product supply KPI settings are very difficult. Even for products and materials that we think are good, there are many unpredictable factors, such as market trends, which affect whether or not customers will appreciate and purchase them. If we do not sufficiently anticipate and foresee the needs for the materials the world wants, both the market outlook and the KPI settings will be difficult. On the other hand, I think in regard to the engineering that designs and manufactures



equipment such as electric arc furnaces, we can visualize the extent to which the transition from blast furnaces will contribute to the reduction of CO₂ emissions and improve product efficiency numbers. Bearing such things in mind, we must consider monitoring the progress of material issues in terms of accountability.

How are human resource-related initiatives going?

Yamamoto: Based on the fact that we are required to disclose human capital information under the revised corporate governance code, and that investors are taking more interest in personnel and human resources plans as well as long-term sales and profit plans, in fiscal 2023, we need to put proper discussions about what our initiatives should look like on the agenda. The important point will be how to envision the business portfolio in the next Medium-Term Management Plan. As we are transforming the business portfolio, such as expanding growth businesses and the free forging products business, we need to know the gaps between the personnel needed to implement strategies and our current personnel, and then determine the status of the abilities of our employees. At the same time, if we are going ahead with DX to make up for staffing shortages, in addition to understanding the current gap in the required digital personnel, we need to specifically investigate how to secure such personnel with hiring and reskilling through investment in education.

Human capital is an important factor supporting corporate growth, so I hope we will hold many discussions so that we can clearly explain the mechanisms and the investment plan securing and retaining the personnel who will actually implement the strategy, as well as the results and creative value we expect based on it.

Matsuo: At another company I'm involved in, disclosure of human capital is also listed in the propositions in the Medium-Term Management Plan, but they struggle to identify the human resources suited for management strategy and to establish the methods, indicators, and targets of securing and training human resources. Among the human capital-related indicators listed in the newspapers and other media, some raise questions about their relevance to investment decisions. So I think we should



consider disclosures aligned with Daido Steel's management strategy, independent of external influences.

Jinbo: What I notice in the promotion of diversity is that no change can be seen in the trend of the percentage of female managers. I feel that we need to further foster an awareness and culture that encourages the advancement of women. I also recognize that establishing a workplace environment with consideration for the LGBTQ community will be a challenge going forward. Although our awareness of sexual minorities is growing day by day, I do not think we have resolved the issues they face. Based on the knowledge acquired in supporting university students, I will give careful consideration to enabling people with diverse backgrounds to work here without any problems.

Please tell us about the changes in the function and effectiveness of the Audit & Supervisory Committee in the year since it was established.

Matsuo: As you know, the Audit & Supervisory Board has changed to the Audit & Supervisory Committee, and as a result of discussions among the three members of the Audit & Supervisory Committee, including myself, about enhancing internal audits, it was decided that we would receive monthly reports from the Secretariat Division of the CRM Committee, which is responsible for Daido Steel's compliance, risk management, and internal audits. As a result, I feel that there is quite a lot more depth in the reports that the committee members receive. Based on the information gleaned from these reports,

we summarized the internal management issues, including the Group companies, and made a report not to the President and the Audit & Supervisory Committee, but to the outside directors. This expands the scope of audits conducted by the Audit & Supervisory Committee beyond the traditional legality audits handled by the Audit & Supervisory Board. I believe this change in the Audit & Supervisory Committee contributes to increased governance effectiveness by verifying the appropriateness of operations.

Ishiguro: Thank you for the very valuable feedback you have shared here today. Based on the feedback we received, we will work to increase the sophistication of sustainability management and to enhance our corporate value.



A message from the newly appointed outside director

Noriyuki Hiramitsu Outside Director

I am honored to have been added as a member of the Board of Directors of the venerable Daido Steel, which continues to firmly maintain an established position in the specialty steel industry.

Until now, I have been involved as an engineer in steelworks operations including production management, investment management, and organizational management through on-site management and the building of steelmaking processes. During this time, I have constantly implemented reform (improvement) and growth measures. No matter what kind of operations, the lesson I learned the hard way is that without a stable base of corporate activities, we cannot focus on our efforts on proactive initiatives, leading to a delay in growth.

Daido Steel has the technological and solution capabilities cultivated over 100 years of history and in a rapidly changing environment. With ESG at the base of its management policy, the Company has strengthened the foundation of its corporate activities by pursuing appropriate margins and an optimal portfolio, enhancing production elasticity, drastically reforming operations through DX, and strengthening the development of people to support these efforts. Furthermore, the Company has been striving with a

management vision for further progress, such as expanding overseas with an eye to the future in growth areas.

To progress steadily along the path of growth, we need sound and sincere initiatives based on the current social environment. Needless to say, as SDGs and D&I spread and social and individual values are changing greatly, the social responsibilities of companies are increasing more than ever, demanding stronger governance. In such an environment, we need to thoroughly eliminate risks by identifying and preemptively addressing all specific risks through both inductive and deductive approaches, and to build a more complete base for corporate activities. In this regard, as a member of the same steel and manufacturing industry, and as a person who has also been trained in a company rooted in local communities, I believe I can contribute to the Company.

Based on the conviction that thinking and decisions based on facts, logic, and figures will bring the correct results, I want to play a role in the steady and speedy growth of Daido Steel.



Strengthening Governance

Strengthening of Corporate Governance

Corporate governance

Daido Steel views corporate governance as one of the key issues for management in today's rapidly changing business environment. We strive to increase management efficiency, accelerate and improve decision-making, and ensure management transparency. As a company that is listed on the

stock exchange, we conform with the concepts of the corporate governance code, and we work to refer to feedback from stakeholders, and in particular shareholders, in improving the governance level.

Governance system

Daido Steel made the transition to a company with an Audit & Supervisory Committee in June 2022 for the purpose of speeding up management decisions, enhancing medium- to long-term corporate value, and further strengthening the governance system.

With the transition to a company with an Audit & Supervisory Committee, part of the execution of operations that was a matter to be discussed by the Board of Directors has been delegated to the President in an effort to increase medium- to long-term corporate value by speeding up decision making and focusing the content of deliberation in the Board of Directors on management policy and management strategy.

In order to secure a system that enables supervision and monitoring, the delegated matters are deliberated in the management meeting attended by directors who are full-time

Audit & Supervisory Committee members or in the committee, depending on the contents of the matters to be discussed. Furthermore, efforts are made to further strengthen the Board of Directors' governance of management by giving directors who are Audit & Supervisory Committee members the right to vote in the Board of Directors.

Number of members of the Board of Directors pursuant to the Articles of Incorporation	19
Number of directors as of July 2023	13
Number of independent outside directors	5
Number of Audit & Supervisory Committee members	3
Term of directors who are not Audit & Supervisory Committee members	1 year
Term of directors who are Audit & Supervisory Committee members	2 years

Business execution and auditing and internal control mechanisms

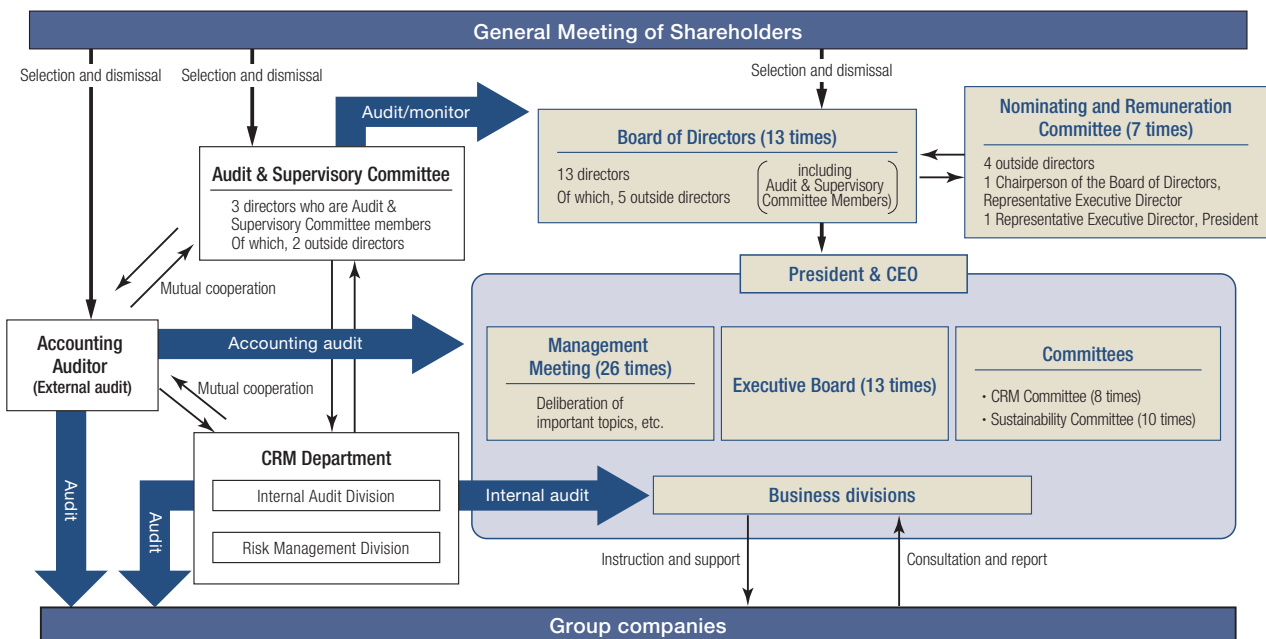

(Note) CRM Committee: Corporate Risk Management Committee
 CRM Department: Corporate Risk Management Department
 Figures in parentheses indicate the number of meetings held in fiscal 2022.

The state of Daido Steel's corporate governance report is disclosed on the Company's website.

<https://www.daido.co.jp/common/pdf/pages/ir/policy/governance/governance.pdf> (Japanese only)

Board of Directors

The company rules specify that, as a rule, the Board of Directors meeting is held once a month, and in the year ending March 31, 2023 it was held a total of 13 times.

The matters to be discussed and reported for deliberation by the Board of Directors are specified in the company rules. The matters to be discussed include proposals to be submitted at the General Meeting of Shareholders, matters related to the directors and executive officers, etc., matters related to important business plans, and matters related to the settlement of accounts. Of the matters to be discussed, some matters involving business execution, other than those specified under laws and regulations and the Articles of Incorporation, are handled as matters delegated by the President, allowing the

focus at the Board of Directors meetings to be deliberation on matters such as management policy and management strategy. Matters to be reported specify reports on the status of business execution specified under laws and regulations, as well as others including reports on the progress and results of matters to be discussed by the Board of Directors.

In addition, of the matters related to the directors, the executive officers, etc., the selection and dismissal and the remuneration of officers is discussed by the Board of Directors after consultation with the Nominating and Remuneration Committee, which is a voluntary advisory organ to the Board of Directors. The majority of members of this Committee are independent outside directors, and the Committee works to ensure transparency and objectivity.

Audit & Supervisory Committee

The company rules specify that, as a rule, the Audit & Supervisory Committee meeting is held once a month, and in the year ending March 31, 2023 it was held a total of 10 times (13 times when combined with the three meetings of the Audit & Supervisory Board prior to the transition to a company with an Audit & Supervisory Committee).

The Audit & Supervisory Committee is composed of three members, two of whom are qualified as independent outside directors, and their specialties and overall career are considered during selection.

The members of the Audit & Supervisory Committee supervise and audit the Directors' execution of their duties by such means as attendance at Board of Directors meetings, periodic interviews with the Representative Executive Director, and various field audits including Group companies. In close collaboration with the Internal Audit Division (CRM Department), they help to maintain the soundness of management through efforts that include participation in a variety of meetings, operation of the whistle-blower system, and direct instructions for supervision and auditing.

Nominating and Remuneration Committee

Daido Steel has established a Nominating and Remuneration Committee as a voluntary advisory organ to the Board of Directors. The Committee is composed of six members: the Chairperson of the Board of Directors and Representative Executive Director (the chairperson of the Committee), the Representative Executive Director, President, and four independent outside directors (one of whom is a member of the Audit & Supervisory Committee). The majority of members are independent outside directors, ensuring transparency and objectivity.

The matters on which the Committee consults are:

- (1) matters related to the selection and dismissal of directors
- (2) matters related to the selection and dismissal of the Representative Executive Director and the executive directors
- (3) matters related to officer remuneration

(4) matters related to the succession planning for the CEO and others

(5) Other matters for which the Representative Executive Director desires the opinions of the Committee.

The Committee met seven times in the year ending March 31, 2023. As for the content of the meetings, matters related to the nomination of officers in (1) and (2) were discussed four times, matters related to the officer remuneration in (3) were discussed three times, and matters related to the succession planning for the CEO in (4) were discussed twice (there is overlap). Regarding the nomination and remuneration of officers, the opinions of the Committee are respected, such as consulting with the Board of Directors after consultation within the Committee and reporting the content of the Committee in Board of Directors meetings.

Officer remuneration

Remuneration of directors (excluding directors who are members of the Audit & Supervisory Committee and outside directors) is paid in cash and stocks, and remuneration of outside directors and directors who are members of the Audit & Supervisory Committee is paid in cash. The remuneration levels are determined by setting the level of remuneration upon achievement of business results and the ratio of fixed remuneration to performance-linked remuneration, referring to profit levels in the executive remuneration survey conducted by a third-party organization as well as examples of companies with comparable market capitalization. The levels are designed so that the higher the position, the higher the ratio of performance-linked remuneration.

Specific remuneration is discussed by the Board of Directors via the Nominating and Remuneration Committee, striving to keep the decision-making process transparent and objective. Remuneration of directors who are Audit & Supervisory Committee members is determined based on discussion in the Audit & Supervisory Committee.

[Monthly remuneration]

This is calculated based on the remuneration table for each position within the scope of the monthly limit on remuneration specified in the Shareholders' Meeting. For directors (excluding directors who are members of the Audit & Supervisory

Strengthening of Corporate Governance

Committee and outside directors), some performance-linked remuneration up to the month of June 2023 has been included in the monthly remuneration, but with the introduction of the stock-based remuneration scheme, performance-linked remuneration will be paid with bonuses and stock-based remuneration, and remuneration from July 2023 will only be fixed remuneration for each position.

(Details of Resolutions of the 98th Annual General Meeting of Shareholders)

- Maximum amount of remuneration for directors (excluding directors who are members of the Audit & Supervisory Committee)

Limited to ¥41 million/month

- Maximum amount of remuneration for directors who are members of the Audit & Supervisory Committee

Limited to ¥8 million/month

[Bonuses]

Bonuses are paid to directors (excluding directors who are members of the Audit & Supervisory Committee and outside directors) annually at a specified time. The performance indicators for bonuses are non-consolidated ordinary income (evaluation weight 80%) and individual performance evaluation (evaluation weight 20%). The reason for using non-consolidated ordinary income is that it is a business outcome in which business execution results are directly reflected.

Regarding the payment amount of the performance-linked part, the standard payment amount for each position is specified, with a payment ratio of 100% (=standard payment amount) when performance results are achieved and a payment ratio that fluctuates within a range of 0 to 200% according to the extent of the achievement (not paid when there are no dividends).

The calculation method of the payment ratio is as follows.

Non-consolidated ordinary income amount

Performance achievement ratio	Payment ratio
200% or more	200%
25% or more, and less than 200%	Result value ÷ Target value
Less than 25%	0%

Bonuses are paid in accordance with the Determination Policy discussed by the Board of Directors after approval of the total payment amount by a resolution of the General Meeting of Shareholders.

[Stock-based remuneration]

Within the range of the limits specified at the General Meeting of Shareholders, the restricted stocks specified for each position are issued to directors (excluding directors who are members of the Audit & Supervisory Committee and outside directors) annually at a specified time through a stock issuance trust.

Stock-based remuneration is composed of a fixed part paid as the auditing function of the directors and a performance-linked part paid as execution results. The fixed part is the issuance of stocks corresponding to a certain amount regardless of position. The KPIs of the performance-linked part are consolidated operating profit (evaluation weight 50%) and consolidated ROE (evaluation weight 50%). The reason for using these two is that they are medium-term target values and they promote incentives for achieving the Medium-Term Management Plan. The stock issuance of the performance-linked part specifies the standard amount for each position, with a payment ratio of 100% (=standard amount) when performance results are achieved and a payment ratio that fluctuates within a range of 50 to 150% according to the extent of the performance achievement (not paid when there are no dividends). By issuing certain stocks combined with the fixed part, setting the lower limit of the payment ratio at 50% promotes management from the perspective of the shareholders and increased medium- to long-term shareholder value and increases sustainable corporate value.

The calculation method of the payment ratio is as follows.

Consolidated operating profit

Performance achievement ratio	Payment ratio
150% or more	150%
50% or more, and less than 150%	Result value ÷ Target value
Less than 50%	50%

Consolidated ROE

Performance achievement ratio	Payment ratio
Baseline value + 2% or more	150%
Baseline value + 1% or more, and less than 2%	125%
Baseline value + less than 1%	100%
Baseline value - 1% or less	75%
Baseline value more than - 1%	50%

In addition, in the stock-based remuneration scheme, a remuneration return clause (malus and clawback clause) is specified. If a scandal or other misconduct related to a director (including those who have retired or resigned) occurs, Daido Steel may demand that they return all or part of the stock. (Details of Resolutions of the 99th Annual General Meeting of Shareholders)

- The applicable period during which points are granted to directors (excluding directors who are members of the Audit & Supervisory Committee and outside directors) shall be specified, and the upper limit of the amount contributed to the trust in the approximately four years corresponding to the initial applicable period shall be ¥600 million or less, and the upper limit of the number of points to be granted shall be 50,000 points (1 point = 1 stock) or less per business year.

Evaluation of effectiveness of the Board of Directors

Since fiscal 2016, Daido Steel has performed an evaluation of the effectiveness of the Board of Directors, targeting all directors. Until fiscal 2021, this was done by means of a survey using in-house questionnaires, but from fiscal 2022 we have switched to an evaluation by a third-party organization with the goal of expanding the content and increasing the objectivity of the evaluation. Along with the results of the evaluation, matters such as an action plan to improve items with low evaluation results are reported to the Board of Directors. Issues and the improvement action results and action plans are as follows.

(1) Fiscal 2021 issues and results of actions**[Issues]**

- a. Review of succession planning for CEO and others
- b. Strengthening of IR activities and timely and appropriate feedback to the Board of Directors

[Results of actions]

- a. Taking action while deliberating in the Nominating and Remuneration Committee.
- b. From fiscal 2022, strengthening of IR activities, such as enhancing disclosure of every kind of information through events such as ESG briefings and initiating IR activities for overseas and individual investors. Strengthening of activities will continue in fiscal 2023.

(2) Fiscal 2022 issues and fiscal 2023 action plans**[Issues]**

- c. Potential risks of the entire Daido Steel Group and the corresponding responses and Crisis Management System
- d. Feedback from dialogue with shareholders

- e. Designing the management remuneration scheme and the specific amounts of remuneration

[Action plans]

- c. Appropriate reporting at Board of Directors meetings, seeking their opinions, and increasing effectiveness.
- d. Began initiatives for SR activities and reported the content of IR activity strengthening at this fiscal year's Board of Directors meetings. Efforts will be made to further strengthen activities by referring to the opinions raised at Board of Directors meetings.
- e. Reviewed the remuneration structure and remuneration levels from fiscal 2022 from scratch, discussed the introduction of a performance-linked, stock-based remuneration scheme for officers, as a result of multiple discussions by the Nominating and Remuneration Committee, at the Annual General Meeting of Shareholders held on June 27, 2023, and decided to revise the officer remuneration structure at the Board of Directors meeting on the same day.

Going forward, we will continue efforts to improve effectiveness.

Skill matrix

The seven skill objectives and types

Skills forming the basis for corporate management	(1) ESG Management/Planning (2) Manufacturing Technology/R&D (3) Sales/Marketing (4) Finance/Accounting
Skills to focus on that will be essential for business operations in the future	(5) IT (6) Overseas business
Skills required in non-financial aspects	(7) Legal/Compliance

The seven skills were decided by the Board of Directors, with the opinions of the Nominating and Remuneration Committee as references. The skills required will be reviewed based on the business environment and the demands of society.

	Name	ESG Management/ Planning	Manufacturing Technology/ R&D	Sales/ Marketing	Finance/ Accounting	IT	Overseas Business	Legal/ Compliance	Independent Officer	Nominating and Remuneration Committee	Number of Board of Directors meetings attended in FY2022	Number of Audit & Supervisory Committee/ Audit & Supervisory Board meetings attended in FY2022
Director	Takeshi Ishiguro	○		○			○			Chair	13/13 (100%)	
	Tetsuya Shimizu	○	○				○			Member	13/13 (100%)	
	Tsukasa Nishimura	○	○					○			13/13 (100%)	
	Toshiaki Yamashita	○		○							13/13 (100%)	
	Akihito Kajita			○	○	○		○			13/13 (100%)	
	Tatsushi Iwata	○		○	○		○				–	
	Tadayuki Kashima	○	○								–	
	Mutsuko Jinbo		○						○	Member	13/13 (100%)	
	Ryoichi Yamamoto	○		○					○	Member	13/13 (100%)	
	Noriyuki Hiramitsu		○				○		○	Member	–	
Audit & Supervisory Committee members	Kenji Matsuo	○		○	○				○	Member	12/13 (92%)	13/13 (100%)
	Kiyoshi Mizutani	○		○	○		○	○	○		13/13 (100%)	13/13 (100%)
	Susumu Shimura	○	○					○			13/13 (100%)	13/13 (100%)

Strengthening of Corporate Governance

Ensuring diversity of the Board of Directors

When selecting directors, perspectives that are able to deal with the management of and the issues in each business and to exchange diverse opinions for the improvement of effectiveness of the Board of Directors are among those that are viewed as important. The composition of the current Board of Directors is based on viewing ensuring diversity in gender, age, and career history as important, in addition to individual capabilities as knowledge, experience and skills and a global perspective.

Progress in strengthening of corporate governance

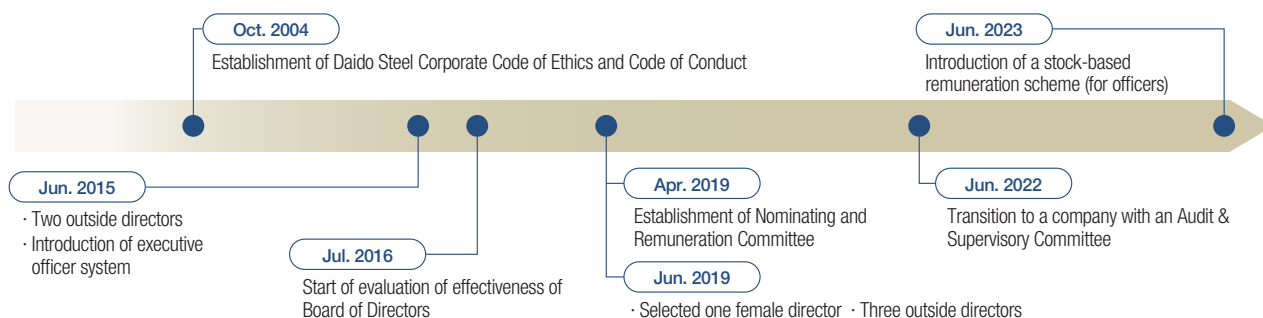

Susumu Shimura, Director and Member of the Audit & Supervisory Committee



It has been approximately nine years since the Corporate Governance Code came into effect, and in that time, Daido Steel has also carried out appropriate changes in organizational design related to the Company's governance. The history of our company's governance

(beginning with the introduction of the executive officer system, and including the establishment of the Nominating and Remuneration Committee, the response to the new Prime securities market, and the transition from a company with an Audit & Supervisory Board to a company with an Audit & Supervisory Committee) has coincided with my time as an executive officer leading up to my membership on the Audit & Supervisory Board and then on the current Audit & Supervisory Committee, and I have been experiencing the evolution of Daido Steel's governance response in real-time.

The required level of governance demanded of companies and corporate groups these days is much higher than it used to be, but in the background, society and the environment have been changing, and I think the common sense formed by the society of that era has become one of the yardsticks for what governance should look like. I also think that the so-called adaptability and flexibility companies needed in order to survive also applies to the governance response.

Through the operation of the Audit & Supervisory Committee since the previous fiscal year, we have been closely monitoring the evolution of Daido Steel's governance and whether its format has not been a formalized process but accompanied by practical details. At the moment, I feel that this evolution is expanding well for the most part, but I think that, going forward, we should thoroughly consider our concept of the governance that will deal with the remaining issues in the details and the gap between what we want them to look like in the future.

From now on, I hope we will work together with the executive side so that the governance of Daido Steel and the Group companies will become more evolved, able to respond to the demands of the times and gain more acceptance and trust from all stakeholders.

Kiyoshi Mizutani, Director and Member of the Audit & Supervisory Committee



In the period of just over four years since June 2019, when I took up this post at Daido Steel, I have recognized that the problem-solving under the Company's corporate governance (hereinafter, CG) has been steadily progressing.

Especially, I have the strong feeling that, since two new departments, the ESG Management Department and the Corporate Communication Section, were established in fiscal 2022, the pace of problem-solving has accelerated.

On the other hand, the demands society makes on our CG have been continuously rising to ever-higher levels. In particular, recently there have been loud calls to strengthen human resources, but I feel that the Company is lagging behind in such initiatives. We need to recognize investment in people as a management issue and reinforce our efforts, but I think the biggest issue in this is the promotion of diversity. The government (Gender Equality Bureau Cabinet Office) requires that the target level for the ratio of female officers (directors, auditors, executive officers) at companies listed in the Tokyo Stock Exchange's Prime segment to be 30% or higher as of 2030, and a movement has also been seen among institutional investors that views the circumstances of the appointment of female officers as important material for determining whether or not to approve agenda items in the selection of directors of a portfolio company. In Daido Steel's latest CG report, we disclosed the doubling of women in managerial positions from 15 as of May 2023 to 30 in 2030. However, bearing in mind that the current composition of officers is such that there is only one woman out of a total of 13 directors, and the executive officers are all men, I am very concerned about whether we will be able to reach the level of the 2030 targets set by the government. I think that, in the future, we will be required to ensure diversity that includes not only women but foreign nationals, people with disabilities, sexual minorities, and others as targets. In the Company's management, I hope we will work with the idea that broadly expanding diversity initiatives and incorporating diverse knowledge, backgrounds, and values by promoting them is an essential management challenge.

Cross-shareholdings

Cross-shareholdings policy for listed stocks

We believe that cooperative relationships with related companies are essential in all areas of business conducted by the Company, such as procurement of raw materials and others, development, manufacture and sale of products, and stable supply. To achieve sustained growth in future, we believe it is necessary to maintain relationships of trust with stakeholders and increase medium- to long-term corporate value. Therefore, our basic policy is to reduce cross-shareholdings as a whole while only continuing appropriate holdings in light of the perspective of increasing corporate value.

Review of Cross-shareholdings

Every year, Daido Steel reviews the confirmation of the purpose and appropriateness of holding individual cross-shareholdings in the Board of Directors. The appropriateness of holdings is reviewed by performing a quantitative review of financial stability, share price and dividends of the portfolio company, and a qualitative evaluation of the importance in Daido Steel's business by considering the amount sold to or from the portfolio company, the amount of profit and the amount of financial transactions. Holdings will be reduced if not found to be appropriate according to the conditions in future.

In the 2023 Medium-Term Management Plan, we decided to reduce the amount of cross-shareholdings (excluding deemed shareholdings) to 20% or less of net assets with an aim to reduce it to 10% in the long term. In fiscal 2021, which was the first fiscal year covered by the plan, we reduced holdings of six stocks by ¥7.4 billion, and in fiscal 2022, which was the second year, we reduced holdings of six stocks by ¥1.6 billion, bringing the

amount of cross-shareholdings (excluding deemed shareholdings) to 17.7% of net assets. And then, during fiscal 2023, we intend to make a further reduction aiming to lower cross-shareholdings including deemed shareholdings to 20% or less of net assets. The ratio of cross-shareholdings including deemed shareholdings to net assets at the end of fiscal 2022 was 24.3%.

Changes in reduction of cross-shareholdings

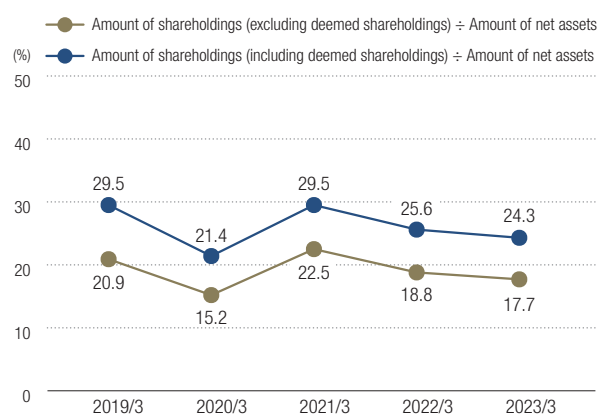

Voting Criteria

Daido Steel exercises its voting rights by making comprehensive decisions based on the issuing company not performing antisocial acts, whether the proposal will contribute to enhancing the medium- to long-term corporate value of the issuing company, and the impact on the Company.

Strengthening Governance

List of officers

(As of June 27, 2023)

Directors



Takeshi Ishiguro

Chairperson of the Board of Directors, Representative Executive Director

Bio
Apr. 1980 Joined Daido Steel Co., Ltd.
Jun. 2023 Chairperson of the Board of Directors, Representative Executive Director (current position)



Tetsuya Shimizu

President, Representative Executive Director

Bio
Apr. 1985 Joined Daido Steel Co., Ltd.
Jun. 2023 President & CEO, Representative Executive Director (current position)



Tsukasa Nishimura

Representative Executive Director, Executive Vice President

Bio
Apr. 1981 Joined Daido Steel Co., Ltd.
Jun. 2016 Representative Executive Director, Executive Vice President (current position)



Toshiaki Yamashita

Representative Executive Director, Executive Vice President

Bio
Apr. 1986 Joined Daido Steel Co., Ltd.
Jun. 2023 Representative Executive Director, Executive Vice President, General Manager, Specialty Steel Business Division, and General Manager, Tool Steel Business Division, and General Manager, Tokyo Head Office (current position)



Akihito Kajita

Director

Bio
Apr. 1986 Joined The Industrial Bank of Japan, Limited
Jun. 2021 Director, Managing Executive Officer (current position)



Tatsushi Iwata

Director

Bio
Apr. 1987 Joined Daido Steel Co., Ltd.
Jun. 2023 Director, Managing Executive Officer (current position)



Tadayuki Kashima

Director

Bio
Apr. 1987 Joined Daido Steel Co., Ltd.
Jun. 2023 Director, Managing Executive Officer, General Manager of Production Division (current position)

Outside Directors



Mutsuko Jinbo

Outside Director
<Independent Officer>

Bio
Mar. 1992 Acquired Doctor of Engineering at Nagoya University
Apr. 1996 Assistant Professor of Materials Engineering Laboratory, Daido Institute of Technology
Apr. 2001 Professor, School of Engineering, Daido Institute of Technology
Apr. 2017 Director of Daido Educational Institutions
Apr. 2017 President of Daido University
Jun. 2019 Director of Daido Steel Co., Ltd. (current position)
Apr. 2023 Advisor, Daido Educational Institutions (current position)
Apr. 2023 Research Fellow, Graduate School of Engineering, Mie University



Ryoichi Yamamoto

Outside Director
<Independent Officer>

Bio
Apr. 1973 Joined The Daimaru, Inc.
Feb. 1993 Manager of Sales Planning Department, Osaka Umeda Store
Feb. 2001 Director, and General Manager of Sales Reform Promotion Office and General Manager of Sales Planning Office, Department Store Operations Headquarters, Head Office
May 2003 President and COO
Sep. 2007 Director, J. FRONT RETAILING Co., Ltd., Director, Matsuzakaya Co., Ltd.
Mar. 2010 President of Daimaru Matsuzakaya Department Stores Co. Ltd.
Apr. 2013 President of J. FRONT RETAILING Co., Ltd.
May 2017 Director, President, and Representative Executive Officer
May 2020 Director and Board of Directors Chairperson (current position)
Jun. 2021 Director of Daido Steel Co., Ltd. (current position)



Noriyuki Hiramitsu

Outside Director
<Independent Officer>

Bio
Apr. 1991 Joined Nippon Steel Corporation
Apr. 2016 General Manager, Head of Div., Production & Technical Control Division, Nagoya Works, Nippon Steel & Sumitomo Metal Corporation
Apr. 2018 Assistant Head of Works, Nagoya Works, Nippon Steel & Sumitomo Metal Corporation
Apr. 2020 Executive Officer, Head of Center, Plant Engineering and Facility Management Center, Nippon Steel Corporation
Apr. 2023 Managing Executive Officer, Head of Works, Nagoya Works, Nippon Steel Corporation (current position)
Jun. 2023 Director of Daido Steel Co., Ltd. (current position)

Reason for selection of independent outside directors

Mutsuko Jinbo	It was determined that she is well qualified because she was involved in management as the director of an educational corporation and the president of a university until March 2023, and, having been active as a professor for many years, she has a wide range of experience and knowledge.
Ryoichi Yamamoto	It was determined that he is well qualified because he has served for many years as a Representative Executive Director and a Representative Executive Officer in different industries than that of Daido Steel, and he has a wide range of experience and knowledge.
Noriyuki Hiramitsu	It was determined that he is well qualified because he has a wide range of experience and knowledge as a management executive of a leading company in the steel industry.
Kenji Matsuo	It was determined that he is well qualified because he has a wide range of knowledge and insight on management based on his experience in top management of a financial institution.
Kiyoshi Mizutani	It was determined that he is well qualified because he has a wide range of knowledge and insight on management based on his experience as a management executive of financial institutions and full-time audit & supervisory board member of an operating company.

Directors and members of the Audit & Supervisory Committee



Kenji Matsuo

Director, Audit &
Supervisory Committee
Member
<Independent Officer>

Bio
Apr. 1973 Joined Meiji Life Insurance Company
Jul. 2001 Director and General Manager, Real Estate Investment
Department
Apr. 2005 Managing Director of Meiji Yasuda Life Insurance Company
Dec. 2005 President
Jul. 2006 President, Director, Representative Executive Officer
Jul. 2013 Representative Executive Officer
Jul. 2013 Senior Adviser
Jun. 2017 Audit & Supervisory Board Member of Daido Steel Co., Ltd.
Apr. 2022 Honorary Advisor, Meiji Yasuda Life Insurance Company (current
position)
Jun. 2022 Director, Audit & Supervisory Committee Member of Daido
Steel Co., Ltd. (current position)



Kiyoshi Mizutani

Director, Full-Time Audit
& Supervisory Committee
Member
<Independent Officer>

Bio
Apr. 1982 Joined The Tokai Bank, Limited
Jun. 2010 Executive Officer of The Bank of Tokyo-Mitsubishi UFJ,
Ltd.
Jun. 2010 Executive Officer of Mitsubishi UFJ Financial Group, Inc.
Jun. 2012 Deputy President of MST Insurance Service Co., Ltd.
Jun. 2015 Full-Time Audit & Supervisory Board Member of NIPPON
SHARYO, LTD.
Jun. 2019 Full-Time Audit & Supervisory Board Member of Daido
Steel Co., Ltd.
Jun. 2022 Director, Full-Time Audit & Supervisory Committee
Member (current position)



Susumu Shimura

Director, Full-Time Audit
& Supervisory Committee
Member

Bio
Apr. 1981 Joined Daido Steel Co., Ltd.
Jun. 2019 Full-Time Audit & Supervisory Board Member
Jun. 2022 Director, Full-Time Audit & Supervisory Committee
Member (current position)

Executive Officers and the assignment of business operations and commissioning of posts

Position	Name	Assignment of business operations and commissioning of posts
President & CEO	Tetsuya Shimizu	
Executive Vice President	Tsukasa Nishimura	Assistant to the President Supervisor of all departments in charge of CRM Department In charge of risk management and compliance
	Toshiaki Yamashita	Assistant to the President In charge of all sales departments, Sales Management Department, Hot Forming Division General Manager, Specialty Steel Business Division, General Manager, Tool Steel Business Division, General Manager, Tokyo Head Office (commissioned post)
Managing Executive Officer	Takaaki Taketsuru	In charge of Environment Department, Innovative Safety and Health Department, General Affairs Department, Legal Department, Personnel Department, Director's Departmental Section Assistant to Executive Vice President Nishimura for risk management and compliance and the CRM Department Assistant to Managing Executive Officer Iwata for the environment of the ESG Management Department
	Akihito Kajita	In charge of Finance & Accounting Department, IT Planning Department, Internal Control (Financial Instruments and Exchange Act)
	Yuji Noguchi	In charge of Procurement Department, Machinery Division
	Tatsushi Iwata	In charge of Corporate Planning Department, ESG Management Department, Planning Department for Affiliates
	Tadayuki Kashima	In charge of Manufacturing Division, Advanced Manufacturing Department General Manager, Production Division (commissioned post)
	Ikuo Sugie	In charge of Corporate Research & Development Center, Technical Planning & Administration Department Assistant to Executive Vice President Yamashita for the Specialty Steel Technical Service Department Assistant to Managing Executive Officer Iwata for the ESG Management Department reduction of CO ₂ General Manager, Functional Products Business Division (commissioned post)
Executive Officer	Muneyoshi Matsuo	General Manager, Fabricated Materials Business Division (commissioned post)
	Hisashi Hirose	Shibukawa Plant Manager, Production Division (commissioned post)
	Masayasu Nukushina	General Manager, Hot Forming Division (commissioned post)
	Tetsuya Niwa	General Manager, ESG Management Department (commissioned post)
	Akihiro Nagatani	Chita Plant Manager, Production Division (commissioned post)
	Takeshi Watanabe	General Manager, Planning Department for Affiliates (commissioned post)
	Takashi Kano	General Manager, Corporate Planning Department (commissioned post)
	Shin Takamiya	Assistant General Manager, Specialty Steel Business Division, General Manager, Osaka Branch (commissioned post)
Mikine Kishi	Hoshizaki Plant Manager, Production Division (commissioned post)	

Strengthening Governance

Risk Management

Daido Steel believes that risk management and compliance are the starting points for ensuring the continuity of its businesses, and perceive them to be one of the most important management issues.

Risk management system

In order to achieve the sustained growth of the Daido Steel Group, we have established Risk Management Regulations stipulating basic matters on risk management, and are conducting activities accordingly. Based on these regulations, risks are defined as events that could have a detrimental impact on the Company, and we perform comprehensive and integrated tracking and evaluation of risks, determine policies on responses to risks, implement preventative measures, and implement ongoing monitoring of these activities.

To promote these initiatives, an officer who is responsible for risk management and compliance serves as the company-wide supervisor of risk management and compliance. Furthermore, the Corporate Risk Management (CRM) Committee chaired by the President that is an advisory organ to the Board of Directors has been established as an organ to discuss matters related to

the risks surrounding the Daido Steel Group and matters concerning internal control, and it supervises the status of operation of internal controls pertaining to risk management and financial reporting.

The Company periodically formulates and revises a risk map on the risks that impact business operation, assesses risks, and selects important risks related to the Company and notifies the relevant divisions. Furthermore, working groups (WG) are established for risks that should be addressed by the entire company, and they conduct companywide activities and periodically report to the CRM Committee.

Furthermore, we have built a three lines model with the CRM Department as the final line of defense as a system for dealing with various risks, laws and regulations.

Risk management system structure

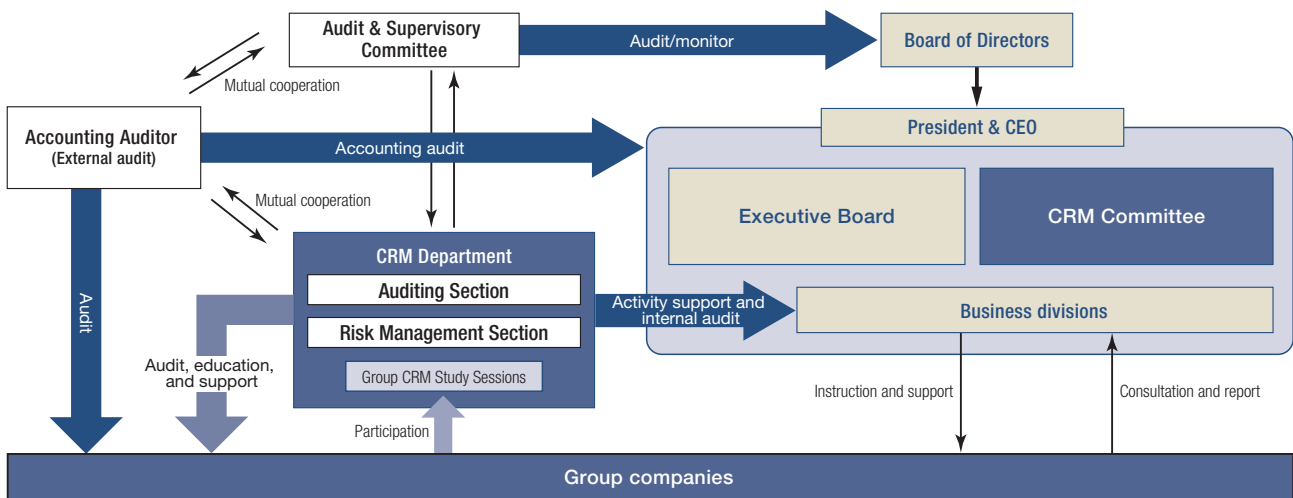
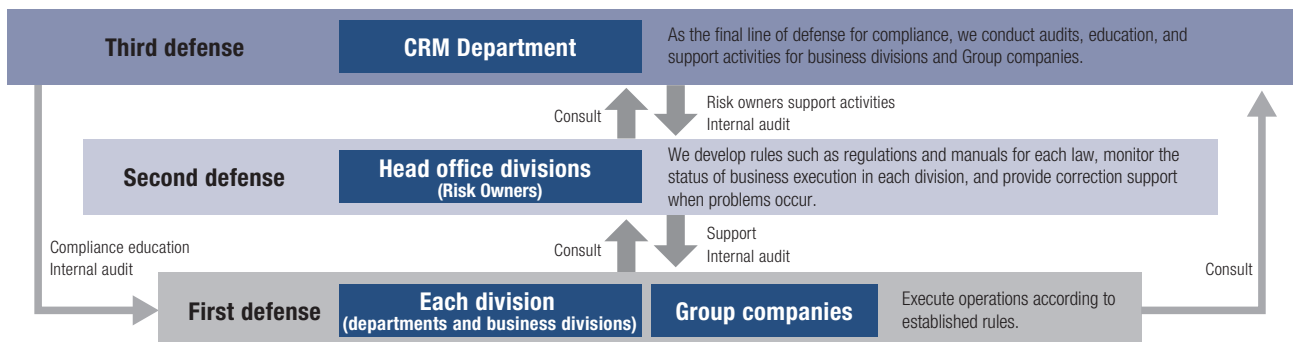

Diagram of the three lines model



Risk map-based risk management activities

Regarding individual risks, the division responsible for companywide risk management is designated as the Risk Owner (2nd Defense). Risks are organized by degree of impact and level of countermeasures and a risk map is created. The risk map is linked to the Medium-Term Management Plan, and each risk

evaluation is reviewed and updated once every three years. The developed risk map is discussed and approved by the CRM Committee, and from among these, working groups are organized to respond to particularly high risks, and measures are taken across the organization as special risks.

Risk map (Excerpted version)

The risk map identifies 81 important risks.

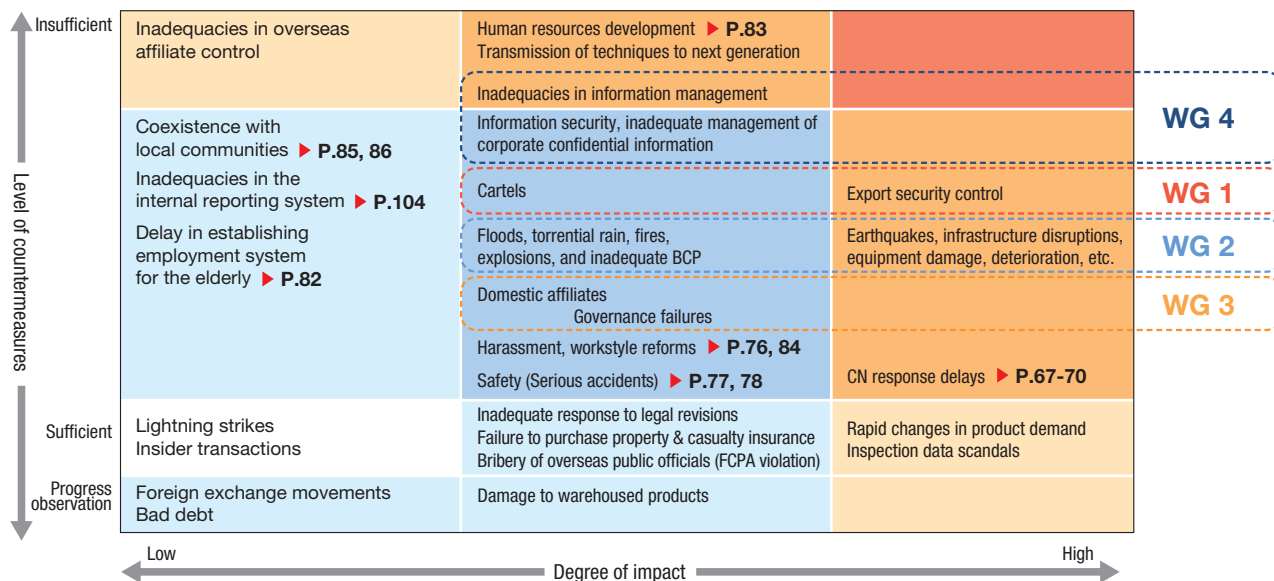

Addressing major risks

For important risks that require a company-wide response, we have organized a working group (WG), and all relevant divisions work as one to carry out risk reduction activities.

WG activities: past results and initiatives from FY2023 onwards

WG Name	Relevant divisions	Activity objective and content
[WG1] Export management and cartel	Compliance risk reduction activities aimed at preventing violations of export security controls (Foreign Exchange and Foreign Trade Act) and competition laws.	
Export Management	Technology Planning & Administration Department Corporate Planning Department CRM Department Legal Department	<ul style="list-style-type: none"> The Export Management Committee, whose members are executives and export management officers, and the Daido Group Export Management Liaison Meeting, whose members are export management officers from Daido Steel Group companies, are held regularly to provide the latest information on legal revisions. Various issues and internal audit results were shared. We have established a workflow system for export management classification review, introduced a system for halting incoming orders, and created a system for more rigorous screening. Additionally, we conduct internal audits and e-learning education for Company and Group companies every year, and will continue to do so in the future.
Cartels	Sales Management Department Legal Department CRM Department	<ul style="list-style-type: none"> Cartel prevention training was provided to all sales divisions to ensure compliance with competition laws. We also create educational content and deliver it to relevant departments. We establish internal rules to prevent cartels and educate employees through e-learning. Additionally, we will conduct internal audits of sales divisions, etc. to reduce the risk of violation of competition laws.

Risk Management

WG Name	Relevant divisions	Activity objective and content
[WG2] BCM	Company-wide BCM activities aimed at business continuity in the event of an emergency (such as a major earthquake)	
Management Committee	Head Office Each management division CRM Department	<ul style="list-style-type: none"> We are formulating a business continuity plan for the head office management division in the event of a major earthquake on the Nankai Trough. Starting in fiscal 2020, we have conducted BCM training once a year to maintain the function of our headquarters, in anticipation of post-disaster response. In fiscal 2023, we will continue to implement initiatives to evolve our operations continuity plan into a more effective business continuity plan based on the issues identified through training up to last year, as well as BCM training with the participation of management.
Disaster Prevention Committee	Technology Planning & Administration Department General Affairs Department Environment Department CRM Department	<ul style="list-style-type: none"> Promoted earthquake and disaster prevention measures at plants. Specifically, we took measures to prevent equipment oil leaks during torrential rain, measures to prevent residual risks of explosions and fires with a focus on saving lives and reducing disasters during power outages, and preparing evacuation routes in case of emergencies. From a BCP perspective, we are also investing in early recovery after power outages through equipment protection. We will continue to implement earthquake resistance, disaster prevention, and mitigation measures.
BCP (Sales) Committee	Sales Management Department CRM Department	<ul style="list-style-type: none"> We screened all products to see if they could be manufactured in an alternative way in an emergency, and considered ways to continue supplying the products. In order to fulfill our responsibility to supply to our customers, we will continue to review and rebuild the BCP of our sales and plant division.
[WG3] Governance of Group companies	Various activities designed to improve the Daido Steel Group's risk management and compliance standards	
	Planning Department for Affiliates CRM Department	<ul style="list-style-type: none"> In order to strengthen the risk management system and improve the effectiveness of its operations across the entire Group, we are implementing detailed responses through Group company-led education and study by theme area and mutual exchange of information activities (Figure: Group CRM study sessions and seven subcommittee activities). We also conduct risk-based education, internal audits, and individual consultations for group companies.
[WG4] Information management	Activities to reduce information security risks by managing personal information, technical information, and other confidential information and by implementing cybersecurity measures	
	General Affairs Department Technology Planning & Administration Department IT Planning Department CRM Department	<ul style="list-style-type: none"> We created an information management guidebook and provided education to all employees through e-learning. We also conducted an internal audit of risk owners. We will continue to conduct regular audits and to provide education in the future. Promoted cybersecurity measures. Measures included strengthening the monitoring system, examining incident response and other measures, conducting training for dealing with fraudulent e-mails, purchasing property & casualty insurance, and publicizing the issues through posters. In fiscal 2023, we will proceed with building a Computer Security Incident Response Team (CSIRT)* system. <p>* Specialized team to respond to information security incidents</p>

Daido Steel Group CRM Subcommittee activity system and results of events held in FY2022

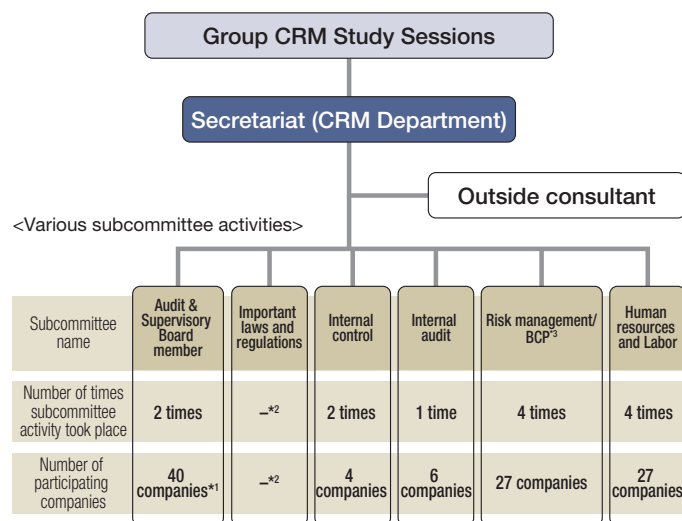

*1 Indicates the number of companies where the target member serves as an Audit & Supervisory Board Member.

*2 In fiscal 2022, we shared information on important law and regulations revisions and legal guide within the Group.

*3 Joint meetings were held by two subcommittees; the Risk Management Subcommittee and the BCP Subcommittee.

Opinions from Daido Steel Group CRM subcommittee activities participants



Hitoshi Iwatsuki
Daido Life Service Co., Ltd.
Planning Department

As a member of the Daido Steel Group, we are engaged in CRM activities, and as part of this we also participate in subcommittees. We are delivering the content of the Risk Management Subcommittee and BCP Subcommittee within the company and working to expand the level of activities such as BCM document formulation and training.

Compliance

Compliance initiatives

In order to secure the trust of all stakeholders and respond to social requirements, Daido Steel considers compliance to be one of the most important management issues and believes it to be a major prerequisite for ensuring the continuity of its businesses. Compliance status is reported to the CRM Committee in a timely manner. In order to instill and ensure thorough compliance, we are vigorously implementing the following various initiatives.

Corporate Code of Ethics, Code of Conduct

Daido Steel has established the Daido Steel Code of Conduct and the Daido Steel Corporate Code of Ethics which every officer and employee of the Company is required to follow. The Code of Conduct Guidebook is distributed to all employees and training is offered to each tier of the workforce. In order to practice sustainable corporate behavior in light of changing social requirements, in August 2023, the contents of the current Daido Steel Corporate Code of Ethics were revised and renamed to the Daido Steel Group Corporate Code of Ethics. In the future, we will also focus on reviewing our conduct standards and publicizing them and providing education.

<Daido Steel Group Corporate Code of Ethics>

Daido Steel strictly observes and adheres to all laws, international rules, and their mindset, both domestically and internationally, and behaves in a socially sensible manner based on the following ten principles.

1. Achieve sustainable economic growth and resolve social issues through technology, service, and quality that maintain the satisfaction and trust of customers and society.
2. Conduct fair, transparent, and free competition, as well as fair trade and responsible procurement. We will also maintain sound and normal relationships with political and administrative institutions.
3. In addition to proactively and fairly disclosing corporate information, we will engage in constructive dialogue with a wide range of stakeholders to improve corporate value.
4. Manage in a way that respects the human rights of all people.
5. Earn customer satisfaction and trust by providing appropriate information regarding products and services and engaging in sincere communication with customers.
6. Respect employees' diversity, personality, and individuality while creating a rewarding work environment that takes safety and health into consideration, and achieves comfort and high quality of life.
7. Environmental issues are something common to all people and we will act proactively as an essential requirement for a company's existence and activities.
8. Conduct all corporate activities as a good corporate citizen in compliance with corporate ethics and legal requirements. Also, give careful attention to protecting personal and customer information. In conducting international corporate activities, we respect various international norms and local cultures and customs, and manage in a way that allows contributions to their development.
9. Take a stringent and resolute attitude toward any unreasonable demands from antisocial forces or organizations that threaten the order and safety of civil society and cut ties with them. In addition, we thoroughly implement organizational crisis management in preparation for terrorism, cyberattacks, natural disasters, etc.
10. To realize the Daido Steel Group Corporate Code of Ethics, the management will take the lead in building effective governance by setting good examples and ensuring that the Corporate Code is thoroughly understood within the Company and Group companies. We will also encourage the supply chain to do the same. In the event of any violation of this code, management shall proactively investigate and resolve the matter, and make a prompt and accurate disclosure of information pertaining to the matter. After such disclosure, management will take measures to prevent recurrence, and will discipline violators appropriately.

Internal reporting system

We have established Internal Reporting Regulations and maintain an internal reporting system to receive consultations and reporting on compliance in Daido Steel and Group companies. In addition to the responsible division and the officers of the Audit & Supervisory Committee, we have established an external point of contact for whistle-blowing, ensuring independence and creating a system in which employees can report with peace of mind. The contents of the whistle-blower report are reported to the officer in charge of risk management and compliance and the Audit &

Supervisory Committee member, and personnel in charge of handling whistle-blowing conduct investigations and corrective actions based on their instructions. Furthermore, the operational status is reported to the CRM Committee, Board of Directors, etc. According to the results of the fiscal 2022 employee compliance awareness survey, awareness of the internal reporting hotline was 91.2%. In the future, we will continue to build a system that allows employees to report incidents with peace of mind and publicize further awareness activities.

How the internal reporting system works

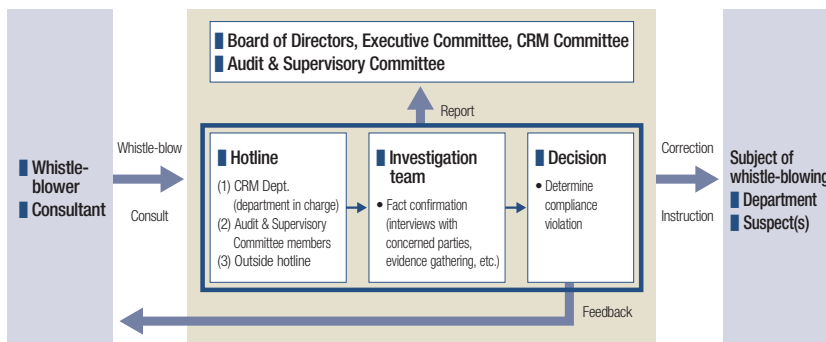

Trend in number of reports

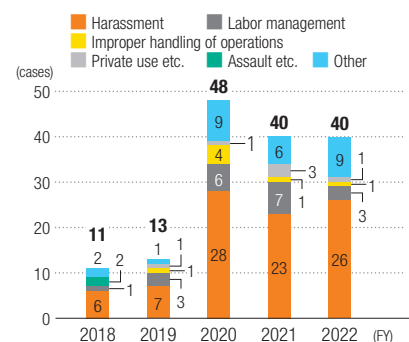

Compliance

Addressing important laws and regulations

The Daido Steel Group has identified important laws and regulations to be followed in the course of business operations and compiled a list of Important Laws and Regulations, evaluating their importance from various angles. The evaluation items include the degree of influence of laws and regulations, the scope of relations, and management. The relevant laws and regulations are scored for each item and then classified into S, A, and B according to the scores.

The Daido Group Important Laws and Regulations are updated regularly, and in February 2023, 267 laws and regulations were

selected. Among these, we are addressing the most important ones, and each risk owner and the CRM department are cooperating to implement e-learning on the Important Laws and Regulations, provide necessary risk-based education, and conduct internal audits. Additionally, information on newly established and revised Daido Group Important Laws and Regulations is distributed to each risk owner within the Company and each Group company, and is also reported to the CRM Committee in a timely manner.

Main S and A rank laws and regulations and actions (FY2022)

Foreign exchange and foreign trade act (export security control)	Implementation of export management education (training for new graduates and within each division) and audits of the Company (50 departments) and Group companies (16 target companies). Holding committees and meetings (Export Management Committee (1 time), Internal Export Management Officer meeting (4 times), Daido Group Export Management liaison meeting (1 time), Secretariat meeting (5 times))
Laws related to the environment (soil, air, water, waste, etc.)	Implemented compliance audits of the Company's plants and offices (nine sites) and Group companies' plants (27 companies). We confirmed the compliance status of the following laws and regulations: Water Pollution Prevention Act, Act on Rational Use and Proper Management of Fluorocarbons, Law Concerning Special Measures against PCB Waste, Poisonous and Deleterious Substances Control Act, Fire Service Act, and Act on Waste Management and Public Cleansing.
Act on the Protection of Personal Information and related laws and regulations	We conducted audits of and interviews with risk owners*. * Act on the Protection of Personal Information Act, etc.: General Affairs Department, Number Act: Personnel Department, Whistle-blower Protection Act: CRM Department (Division in charge of internal reporting system)
Act on Comprehensively Advancing Labor Measures, and Stabilizing the Employment of Workers, and Enriching Workers' Vocational Lives, Act on Securing, Etc. of Equal Opportunity and Treatment between Men and Women in Employment, Act on Childcare Leave, Caregiver Leave, and Other Measures for the Welfare of Workers Caring for Children or Other Family Members	Implementation of harassment prevention education: new section manager and lead supervisors training, education for each tier of the workforce (held online, 19 times in total), face-to-face seminars for all lead supervisors and supervisor in the Company's expert course (160 people), individual training for Group companies (four companies, total of 521 participants).
Labor Standards Act, Industrial Safety and Health Act, etc.	Conducted Group company audits regarding the management of labor hours, etc. (27 companies). Conducted Worker Dispatch Act audits (total of 23 companies).

Elimination of antisocial forces

The Daido Steel Group Corporate Code of Ethics and the Daido Steel Code of Conduct stipulate rejecting antisocial forces, and aim to resolutely confront antisocial forces. We are taking necessary actions with risk owners as the main actors and are

building relationships with outside specialized organizations such as police and lawyers on a daily basis. In addition, we stipulate provisions on the elimination of antisocial forces when concluding agreements with new business partners.

Implementing employee compliance awareness surveys and awareness raising activities

In fiscal 2022, we implemented Employee Compliance Awareness Surveys targeting all employees working at the Company. It is carried out once every few years and managed at fixed points. The response rate was 97.4%. The results of the survey demonstrated that the Company's strengths in terms of compliance culture lie in "a culture that allows lively discussion and deliberation," and "bosses' management behavior," which creates a culture conducive to reporting, communication, and consultation. On the other hand, we discovered vulnerabilities. Employees felt "anxious about the outlook for the company and the future," and expert employees in particular had a "lack of

understanding and sharing of management policies." These are thought to impact not only on the compliance culture but also on employee engagement, so going forward we plan to cooperate more than ever with each division and plant and proactively communicate with employees. These results are reported to the CRM Committee. Going forward, we will continue to conduct investigations and work to identify risks early on and to prevent compliance violations before they occur.

In addition, we are working on awareness-raising activities to foster and instill a sense of compliance among employees.

FY2022 results	<ul style="list-style-type: none"> Keynote address by the officer in charge of risk management and compliance, and delivery of video message to all employees (photo) Publicizing activities in the internal newsletter during Corporate Ethics Month
FY2023 Plan	<ul style="list-style-type: none"> Lectures by outside lecturers during Corporate Ethics Month (Theme: Anti-corruption (Planned)) Internal newsletter compliance special feature



Video message delivered to all employees

Anti-corruption

Anti-corruption policy

To prevent corruption, in 2003, the Daido Steel Group Corporate Code of Ethics specified that we "maintain sound and normal relationships with political and administrative institutions." Through competing for business and conducting appropriate business in a fair, transparent, and free manner, we aim to put the Daido Steel Group's Management Philosophy into practice and realize a future society where people can live affluent lives.

Bribery of and by public officials is regulated in many countries where the Daido Steel Group has expanded operations. Bribery not only eliminates low-cost, high-quality

products and services from the market, but also undermines the fairness and reliability of public affairs and aggravates human rights, labor, and environmental issues. Furthermore, if a company is caught for bribery, it would be fined a large amount of money and lose social credibility, which could threaten its very foundation.

Therefore, in consideration of the above, the Sustainability Committee repeatedly deliberated on top management's commitment to preventing bribery. Based on the Daido Steel Group Management Philosophy, Corporate Code of Ethics, and Sustainability Basic Policy, we established the Daido Steel Group's Anti-Bribery Policy in June of this year, signed by the president, and announced on our website.

<Daido Steel Group's Anti-Bribery Policy (Excerpted version)>

Foreword

- Practice our management philosophy through competing for business and conducting appropriate business in a fair, transparent, and free manner, and strive to realize a future society.
- The Daido Steel Group has set this policy (declaration) based on the Group's awareness and management philosophy regarding bribery.

1. Prohibition of bribery

- Do not engage in any bribery of public officials, etc.
- Do not tolerate such acts for any reason.

2. Development and operation of organizational frameworks

- In order to improve the effectiveness of bribery prevention, we will establish and appropriately operate organizations and systems using a risk-based approach.
- Ensure effectiveness by communicating information in the event of an emergency.

- Take appropriate measures such as reporting to relevant authorities and cooperating with investigations.
- Violators will be appropriately disciplined.

3. Relationship with business partner

- Require compliance with laws and regulations by stipulating anti-bribery provisions in basic transaction contracts.

4. Education

- Engage in educational and awareness raising activities for officers, employees, etc.

5. Monitoring and improvement

- Conduct monitoring regularly.
- The series of processes will be regularly reported to management and efforts will be made to improve them.

The full text of the Daido Steel Group's Anti-Bribery Policy is disclosed on its website.



<https://www.daido.co.jp/en/common/pdf/pages/sustainability/zosyuwai.pdf>

Forthcoming initiatives

In order to continuously ensure the effectiveness of anti-bribery measures, the following measures are being taken. Employees can also use the internal reporting system to report violations.

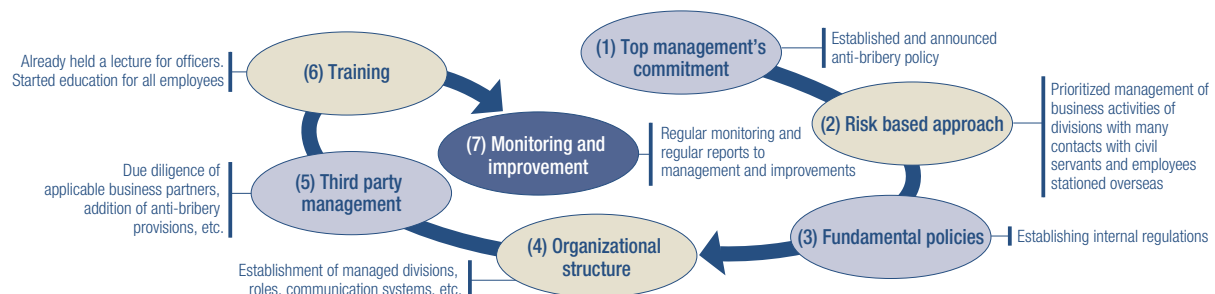

Company status report (FY2018 to FY2022)

The Company does not make any political contributions. In addition, there are no fines, penalties, or settlement payments related to corrupt practices, nor have any of our employees been disciplined for corrupt practices.

Strengthening Governance

Stable Supply of High-quality Products

Initiatives for stable supply of high-quality products

Stable supply of high-performance, high-quality materials is essential for the realization of a sustainable society. Also, stable supply cannot be achieved without assured quality management.

Daido Steel is broadly promoting the improvement of employees' skills and sensitivity to quality, sharing and rolling out of examples of quality improvement and accidents, and activities

to prevent misidentification, including in Group companies. Going forward, we will endeavor to maintain and improve quality to continue to be a materials manufacturer that is a cornerstone of a safe and secure sustainable society by delivering reliable quality to customers.

President's quality policy

"Quality is the source of business competitiveness"
Keep producing goods that consumers can use with confidence

We aim to achieve "zero major quality accidents" based on the President's Quality Policy so that materials with assured quality management may be supplied to fulfill emerging demands in the automotive CASE, semiconductor, and renewable energy areas. Although improvements have been made since fiscal 2018, we aim for zero accidents by going back to the basics of correct procedures and correct work.

Major quality accident index

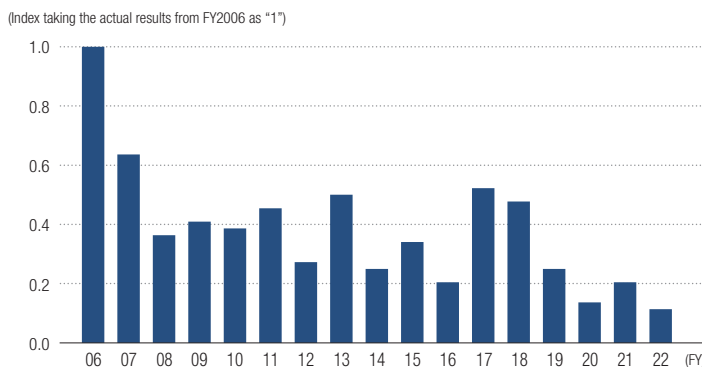

Quality management organization

The Daido Steel Group is promoting quality control improvement measures centered on "Daido Group Quality Assurance Committee." Since 2006, this committee has continued to convene every three months, and in July 2023 it held its 69th meeting. By sharing and rolling out information, improving common quality issues, and introducing examples of improvements, the entire Daido Steel Group is attempting to prevent serious quality incidents.

<Activity examples>

- Elimination of identification failures through the promotion of automation when verifying identification
- Commitment to automation of tests and communication of measurements
- Quality compliance audits by the head office quality assurance section

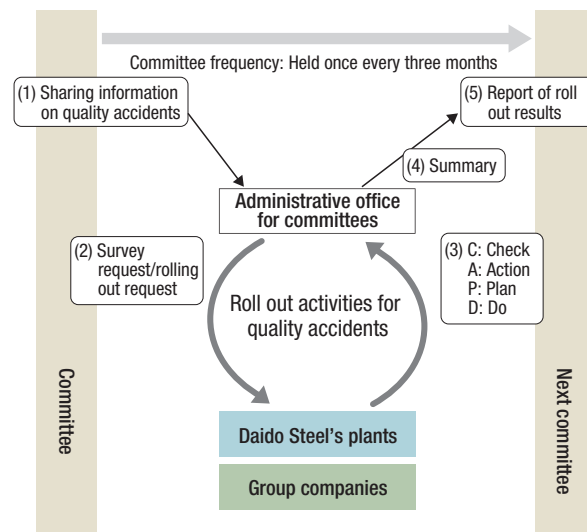
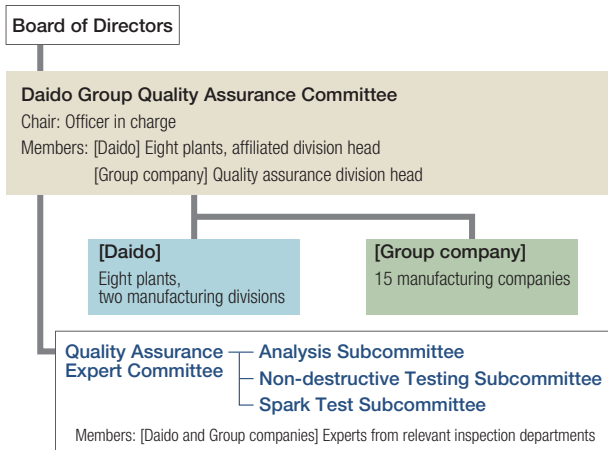

Pursuit of higher quality through participation by all

●Internal education system

In order to develop human resources that support high-quality, we maintain internal education system on quality, such as self-management activity education and practical course on quality investigation.

Self-management activities themes (FY2022):

Daido Steel 1,027 themes, Group companies 817 themes

Practical course on quality inspection (FY2022):

Three participants from Daido Steel, seven participants from Group companies with four sessions in total

●Educational system by each subcommittee

In order to develop testing personnel with a high level of specialized knowledge, the Daido Steel Group jointly organized the Analysis Subcommittee, Non-destructive Testing Subcommittee, and Spark Test Subcommittee in which leaders from the relevant inspection departments participate as a training system for testing personnel. In addition to supporting the training of testing personnel, we also carry out mutual inspections between departments and share knowledge of new technologies.

Analysis Subcommittee

- Activities to maintain precision through mutual analysis using the same standard samples
- Study group on new analysis technology
[Participation] 1 Daido plant, 4 Group companies
[Frequency] Held once every three months

Non-destructive Testing Subcommittee

- Activities to increase the JSNDI qualification test pass rate through the creation of a guide
- Mutual inspection of testing and calibration methods
[Participation] 6 Daido plants, 11 Group companies
[Frequency] Held once every three months

Spark Test Subcommittee

- Periodic practical tests (maintaining skills)
- Spark test competition (improving skills)
- Establishment of a working environment for spark testing
[Participation] 3 Daido plants, 4 Group companies
[Frequency] Held once every three months

Manufacturing with world-class QCD competitiveness

We're aiming for even higher quality, and we're pouring our effort into new technology.

<Improvement example> Installation of automatic visual inspection equipment for forged parts

Previously, appearance inspections were done visually, but we have installed automatic visual inspection equipment that uses 17 cameras to take images and analyze the images to instantly and automatically determine defects, helping to prevent the outflow of defective products.

In addition to improving quality, we were also able to improve operating efficiency and reduce the workload caused by heavy objects.

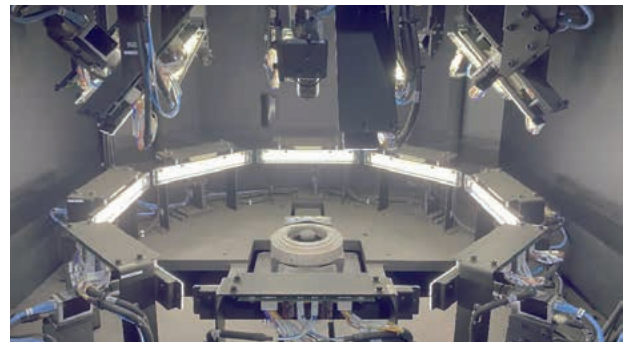

Detection of quality risks and prevention of problems in advance

Mismatched materials and identification errors must not occur, and we are working to strengthen our systems to prevent them. We promote the machine verification of identification and the transmission of test measurement as a Group initiative throughout the Daido Steel Group.

●Machine verification of identification

To prevent visual verification mistakes (human errors), we have added bar code verification and QR code verification to many processes. Recently, OCR reading (character recognition) has also been used.

●Transmission of test measurements

We are promoting the transmission of test measurements to prevent manual measurement error and test scandals. If direct transmission from the test equipment is difficult due to system constraints, we try to avoid human intervention to the extent

possible, such as by converting the data to a QR code and then reading it.

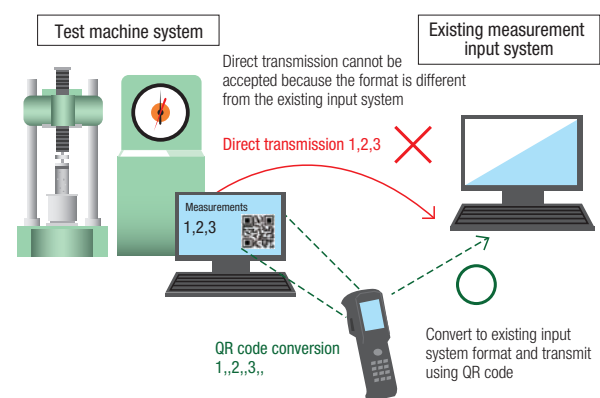

Strengthening Governance

Stakeholder Communication

We are working to achieve sustainable growth and improve corporate value through dialogue with stakeholders. We will continue to provide various opportunities and aim to establish trustworthy relationships.

Stakeholder	Approach	Main initiatives in FY2022 (New or strengthened initiatives are in bold)	
		Content	Number of times/year (month held)
Customer	We aim to be a company that is trusted by customers, and meet their needs with a stable supply of high-quality products.	• Communication through sales activities	As needed
		• Satisfaction surveys and individual hearings	As needed
		• Providing product information on the company website and at exhibitions	As needed
		• Implementation of plant tours	As needed
Local communities	We place great importance on our responsibility and contribution to the local community, and we will deepen our communication with local residents through various events.	• Cleaning activities around plants	As needed (Varies by plant)
		• Firefly viewing (Hoshizaki Plant)	Once (Jun.)
		• Communication with local residents through events held on plant premises	As needed
		• Sporting activities	Once (Dec.)
		• Mécénat activities (sponsoring concerts of outstanding music performers)	Four times (Sep., Oct., Nov., Dec.)
Shareholders and investors	We will work to improve communication and disclose accurate and timely information so that our stakeholders can gain a deeper understanding of the Daido Steel Group.	• Financial results briefings for institutional investors	Four times (Apr., Jul., Oct., Jan.)
		• ESG Briefings	Once (Dec.)
		• Plant tour for shareholders and institutional investors	Shareholders: Twice (Sep., Mar.) Institutional investors: Once (Mar.)
		• IR meeting for overseas institutional investors	As needed
		• Publishing sponsored research reports for overseas institutional investors	Four times (Apr., Jul., Oct., Jan.)
		• Exhibitor at IR events for individual investors	Three times (Twice in Aug., Sep.)
		• Video delivery of financial results briefings on the company website	Four times (Apr., Jul., Oct., Jan.)
Business partners	In order to more completely fulfill our social responsibilities, we promote sustainability initiatives across our whole supply chain.	• Holding DSP (Daido Supplier Partnership) meetings	Once (May)
		• Implementation of CSR questionnaire	Once (May)
		• Support for ESG activities, VAVE, etc.	As needed
Employees	It is assumed that employees will continue to grow and maximize their performance both as a team and individuals, and we aim to build a company where employees can work with vigor and motivation.	• Communication within the workplace	As needed
		• Publishing and operation of internal newsletters (booklets, portal sites) and hearing opinions through questionnaires	As needed
		• Internal reporting system	As needed
		• Introduction of 360 degree evaluation and feedback	Once (Mar.)
		• Work satisfaction surveys	Once
		• Labor-management committee	Four times (Apr., Feb., twice in Mar.)
		• Various level-based training and self-development support	As needed

Evaluation from outside the Company

ESG evaluation institutions



Climate change: B
Water security: B

Certification of public institutions



Aichi Family-friendly Company

Examples of initiatives

Promoting a wide range of SR and IR activities with the establishment of a new organization

In July 2022, we reorganized the public relations division and established a new Corporate Communication Section within the Corporate Planning Department as a division that supervises public relations and IR activities.

The new organization's objective is to strengthen relationships with all stakeholders and increase corporate value, and is promoting activities such as strengthening the dissemination of corporate information, including non-financial information, and building a corporate brand.

In terms of public relations activities, we worked to strengthen the quality of press releases, build positive relationships with various media outlets, and increase corporate awareness. For example, in March 2023, along with a press release announcing the installation of two remelting equipment (VAR) at Chita Second Plant, we invited nine newspaper companies to the Chita Plant and Chita Second Plant for a plant tour. Additionally, in June 2023, we acquired the naming rights to "Crystal-Hiroba," which has been popular for many years in the Sakae underground shopping center in Nagoya City, Aichi Prefecture, and named it "Daido Steel Phenix Square." By doing this, we will aim to increase corporate awareness among people including the young and those not involved in business.

As for our IR activities, we have strengthened information transmission by holding company information briefings for individual investors and publishing sponsored research reports for overseas institutional investors. We have also offered plant tours and ESG information briefings as ways for domestic institutional investors to learn about our business strategy, growth strategy, and sustainability activities.

We will continue to enhance our IR activities by engaging in dialogue with investors through various events.

New initiatives of FY2022

Category	Content
Public relations	Acquired naming rights to the Crystal-Hiroba in the Sakae underground shopping center. To "Daido Steel Phenix Square"
Public relations	Appearance on the TV program "Unknown Gulliver"
Individual IR	Video delivery on the company's website, including financial results briefings and participation in individual investor corporate briefings
Overseas IR	Publication of sponsored research reports (quarterly)
Domestic IR	Plant tours at the Shibukawa Plant
Domestic SR	Implementation of plant tours for individual shareholders, SR interviews for institutional investors

Corporate Communication Section Yoshinari Saito

With the establishment of the Corporate Communication Section, we have aimed to ensure thorough information sharing between the public relations and IR divisions and to maximize its effectiveness. In fiscal 2022, we have implemented new initiatives and are gradually seeing results. We will engage in a wide range of public relations activities in fiscal 2023. As part of our IR efforts, we would like to plan and participate in a number of events in order to achieve synergistic benefits.

**Group expansion of sustainability activities**

The Daido Steel Group works together to expand programs that spread information on a range of sustainability-related topics.

Example of a meeting with participation of Group companies

Name	Objective
Daido Steel Group Environmental Liaison Meeting	Information sharing and risk communication regarding environmental issues and initiatives of each company.
Daido Steel Group Liaison Meeting for CO ₂ Emissions Reduction Promotion	Information sharing and risk communication regarding CO ₂ emission reduction and initiatives of each company.
Affiliate Safety Promotion Committee Safety Research Meetings and Safety Study Sessions	We will share concerns and safety issues in various work processes, discuss measures, and work on disaster and accident prevention activities.
Group CRM study sessions and Seven Subcommittee Activities	We will work to strengthen the Group-wide risk management system and improve the effectiveness of its operations by conducting education and research by theme area and mutual information exchange activities.
Daido Group Quality Assurance Committee	The committee shares and rolls out information on serious quality incidents, improves common quality issues, introduces examples of improvements, and makes quality improvements for the entire Daido Steel Group.

Participation in, and endorsement of initiatives in and out of Japan

Ministry of Economy, Trade and Industry
"GX League Basic Concept"



Japan Keidanren
"Challenge to 30% by 2030"



Administrative office:
Ministry of the Environment
"30by30 Alliance for Biodiversity"



World Steel Association
"Sustainability Charter"



Task Force on Climate-related
Financial Disclosures



United Nations
"Global Compact"

Ten-year Financial Summary

Years ended March 31	FY2014	FY2015	FY2016	FY2017
Net sales	457,731	483,633	460,577	445,122
Operating income	18,977	20,408	24,432	25,513
Ordinary income	20,287	21,729	25,108	26,373
Profit attributable to owners of parent	12,616	10,886	6,746	16,386
R&D expenses	5,160	5,300	5,766	6,205
Capital investment (plan)	26,400	20,600	28,300	32,800
Capital investment (construction)	44,404	30,295	23,205	28,940
Depreciation	20,052	22,436	22,454	23,275
Total assets	557,522	588,590	535,675	574,169
Equity	232,153	256,021	232,832	259,851
Net assets	267,625	292,405	268,345	290,501
Interest-bearing debt	143,085	146,208	136,114	142,599
Net cash provided by (used in) operating activities	28,567	25,739	45,731	28,390
Net cash provided by (used in) investing activities	(34,313)	(32,178)	(23,164)	(26,449)
Net cash provided by (used in) financing activities	(7,633)	(2,792)	(20,164)	(1,843)
Net assets per share	535	590	545	609
Profit attributable to owners of parent per share	29	25	16	39
Equity ratio (%)	41.6	43.5	43.5	45.3
Return on sales (ROS) (%)	4.1	4.2	5.3	5.7
Return on assets (ROA) (%)	3.8	3.8	4.5	4.8
Return on equity (ROE) (%)	5.7	4.5	2.8	6.7
Cash dividends applicable to the year per share (yen)	5.0	6.5	7.5	10.0
<Net sales by segment>				
Specialty steel	250,749	262,438	254,150	228,963
High-performance materials and magnetic materials	159,367	178,513	172,786	163,495
Parts for automobile and industrial equipment	123,776	130,293	131,078	120,331
Engineering	31,980	25,436	28,609	25,587
Trading and service	18,856	21,089	19,612	24,047
(Elimination of intercompany sales)	(127,000)	(134,137)	(145,659)	(117,304)
<Operating income by segment>				
Specialty steel	1,691	3,177	7,560	5,813
High-performance materials and magnetic materials	11,104	13,517	12,331	17,416
Parts for automobile and industrial equipment	3,779	1,023	1,298	(516)
Engineering	1,125	1,652	2,071	1,218
Trading and service	1,280	1,043	1,173	1,583
(Elimination of intercompany income or loss)	(3)	(6)	(2)	(2)

* A one-for-ten reverse stock split of common shares was conducted on October 1, 2017.

(Millions of yen)

FY2018	FY2019	FY2020	FY2021	FY2022	FY2023
505,219	543,255	490,421	412,722	529,667	578,564
36,218	33,815	24,768	10,070	36,982	46,986
36,130	34,343	24,298	12,642	39,200	48,122
23,920	21,182	10,987	4,516	26,894	36,438
5,419	5,638	6,002	4,722	5,785	6,255
38,600	37,200	25,300	12,500	25,500	34,900
35,605	34,413	37,529	24,448	21,027	24,284
20,740	23,171	24,662	25,912	26,797	26,054
642,021	650,697	625,899	665,506	728,187	773,851
284,435	285,508	273,561	303,143	329,713	368,718
316,409	318,140	309,136	339,353	365,004	405,479
160,352	174,998	193,881	198,812	229,090	236,761
31,043	28,114	41,033	33,766	(16,684)	22,634
(30,215)	(33,707)	(39,326)	(29,395)	(14,568)	(20,084)
5,477	5,589	10,526	2,999	19,402	(2,668)
6,672	6,697	6,417	7,111	7,735	8,650
561	497	258	106	631	855
44.3	43.9	43.7	45.6	45.3	47.6
7.2	6.2	5.1	2.4	7.0	8.1
5.9	5.3	3.8	2.0	5.6	6.4
8.8	7.4	3.9	1.6	8.5	10.4
Interim 6.0	130.0	70.0	35.0	180.0	230.0
Year-end 60.0*					
254,808	278,924	241,462	198,218	267,310	290,458
186,809	202,357	181,038	161,254	212,319	237,373
130,807	137,839	120,933	100,355	120,980	135,891
26,974	29,340	27,492	21,259	18,644	19,556
25,612	25,962	31,529	28,954	38,872	41,104
(119,793)	(131,168)	(112,033)	(97,320)	(128,459)	(145,819)
6,478	5,998	5,148	(2,632)	3,827	9,771
22,195	20,694	13,638	12,172	26,650	24,286
3,070	2,308	430	(2,109)	4,979	8,217
1,835	2,291	2,960	858	(1,277)	1,425
2,686	2,527	2,581	1,786	2,834	3,293
(48)	(5)	9	(4)	(31)	(8)

Company Overview

Corporate name: Daido Steel Co., Ltd.

Founded: August 19, 1916

Incorporated: February 1, 1950

President: Tetsuya Shimizu

Number of employees (Non-consolidated):
3,283 (As of March 31, 2023)

Common stock: ¥37,172,464,289

Number of issued shares: 43,448,769 (As of March 31, 2023)

Number of shareholders: 19,449 (As of March 31, 2023)

Principal banks: Mizuho Bank, Ltd., MUFG Bank, Ltd., Mitsubishi UFJ Trust and Banking Corporation

Lead managers: SMBC Nikko Securities Inc., Mizuho Securities Co., Ltd., Mitsubishi UFJ Morgan Stanley Securities Co., Ltd., Nomura Securities Co., Ltd., Daiwa Securities Co. Ltd.

Principal business partners:

<Sales> Nissan Motor Co., Ltd., Honda Motor Co., Ltd., Toyota Motor Corporation, DENSO Corporation, Mitsubishi Heavy Industries, Ltd., IHI Corporation, Nidec Corporation

<Procurement> Chubu Electric Power Co., Inc., TOHO GAS Co., Ltd., Obayashi Corporation, Sumitomo Metal Mining Co., Ltd., MM&KENZAI Corporation, HANWA Co., Ltd.

Principal shareholders:

Name of shareholder	Investment in the Company	
	Number of shares held (thousands of shares)	Investment ratio (%)
The Master Trust Bank of Japan, Ltd. (Trust Account)	4,124	9.67
NIPPON STEEL CORPORATION	3,100	7.27
Custody Bank of Japan, Ltd. (Trust Account)	2,418	5.67
Meiji Yasuda Life Insurance Company	2,075	4.86
Mizuho Bank, Ltd.	1,577	3.69
NHK SPRING CO., LTD.	1,449	3.40
Honda Motor Co., Ltd.	1,305	3.06
MUFG Bank, Ltd.	1,214	2.84
Toyota Motor Corporation	869	2.03
Nippon Steel Kowa Real Estate Co., Ltd.	749	1.75

Note: Excluding treasury stock

List of Group Companies

(As of March 31, 2023)

Name of company	Number of employees	Location	Corporate website address
Specialty Steel			
Daido Die & Mold Steel Solutions Co., Ltd.	499	Daito, Osaka	http://www.daidodms.co.jp/en/
DAIDO DMS MALAYSIA SDN. BHD.	114	Selangor, Malaysia	https://www.daidoamistar.com.my
DAIDO DMS SINGAPORE PTE. LTD.	20	Singapore	–
DAIDO DMS (THAILAND) CO., LTD.	210	Chachoengsao, Thailand	https://www.daidopdm.co.th
Daido Tienwen Steel Co., Ltd.	146	Taoyuan-Hsien, Taiwan	https://www.daidosteel.com.tw
Daido Technica Co., Ltd.	661	Tokai, Aichi	https://www.daido-technica.co.jp
Daido EcoMet Co., Ltd.	163	Tokai, Aichi	http://www.d-ecomet.co.jp
Riken Seiko Co., Ltd.*	251	Chuo-ku, Tokyo	https://www.rkn.co.jp
Tohoku Steel Co., Ltd.*	394	Murata-machi, Shibata-gun, Miyagi	https://www.tohokusteel.com/en/
Maruta Transport Co., Ltd.*	479	Mizuho-ku, Nagoya	https://www.maruta.co.jp
Sakurai Kosan Co., Ltd.*	67	Minami-ku, Nagoya	http://www.sakuraikosan.co.jp
Izumi Denki Kogyo Co., Ltd.*	47	Sumida-ku, Tokyo	http://www.izumidenki.com
Kawaichi Sangyo Co., Ltd.*	183	Kawasaki-ku, Kawasaki	http://www.kawaichi.jp
High-performance Materials and Magnetic Materials			
Nippon Seisen Co., Ltd.	694	Chuo-ku, Osaka	https://www.n-seisen.co.jp/en/
THAI SEISEN CO., LTD.	202	Samutprakarn, Thailand	–
Shimomura Tokushu Seiko Co., Ltd.	295	Ichikawa, Chiba	http://www.sts-shimomura.com/en/
Shimomura Tokushu Seiko (Suzhou) Co., Ltd.	55	Jiangsu Province, China	https://www.stss-shimomura.cn
ORIENTAL SHIMOMURA DRAWING (M) SDN. BHD.	65	Penang, Malaysia	–
Daido Shimomura Steel Manufacturing (Thailand) Co., Ltd.	27	Chonburi, Thailand	–
Daido Electronics Co., Ltd.	261	Nakatsugawa, Gifu	http://www.daido-electronics.co.jp/english/
Daido Electronics (GuangDong) Co., Ltd.	67	Guangdong Province, China	–
Daido Electronics (Suzhou) Co., Ltd.	350	Jiangsu Province, China	–
Daido Electronics (Thailand) Co., Ltd.	443	Ayutthaya, Thailand	–
Nissei Seiko Co., Ltd.	61	Minami-ku, Nagoya	https://www.nssy.co.jp/english/index.html
Parts for Automobile and Industrial Equipment			
FUJI OOZX Inc.	635	Kikugawa, Shizuoka	https://www.oozx.co.jp/en/
FUJI VALVE (GUANGDONG) CORPORATION	160	Guangdong Province, China	–
PT. FUJI OOZX INDONESIA	198	West Java, Indonesia	–
FUJI OOZX MEXICO, S.A. DE C.V.	132	Guanajuato, Mexico	–
Daido Castings Co., Ltd.	445	Minato-ku, Nagoya	http://www.d-cast.jp
Daido Precision Industries Ltd.	228	Toshima-ku, Tokyo	https://www.daidoseimitu.co.jp/e/index.htm
Toyo Sangyo Co., Ltd.	74	Ohira-mura, Kurokawa-gun, Miyagi	https://www.ring-roll-toyo.co.jp/
Japan Drop Forge Co., Ltd.	127	Amagasaki, Hyogo	https://www.j-d-f.co.jp
OHIO STAR FORGE CO.	129	Ohio, U.S.A.	http://www.ohiostar.com
Daido Steel (Thailand) Co., Ltd.	58	Chonburi, Thailand	–
Daido Star Techno Co., Ltd.	276	Shibukawa, Gunma	http://www.dsteku.jp
Engineering			
Daido Machinery Co., Ltd.	316	Minami-ku, Nagoya	http://www.dm-daido.co.jp/english/
Daido Environment Engineering Co., Ltd.	55	Minami-ku, Nagoya	http://www.daido-kankyo.co.jp
Daido Plant Industries Co., Ltd.	66	Minami-ku, Nagoya	https://www.daido-plant.co.jp/en/index.html
Trading and Service			
Daido Kogyo Co., Ltd.	337	Minato-ku, Tokyo	https://www.daidokogyo.co.jp/english/
Daido Kogyo (Thailand) Co., Ltd.	20	Bangkok, Thailand	–
Daido Steel (America) Inc.	10	Illinois, U.S.A.	–
Daido Steel (Shanghai) Co., Ltd.	46	Shanghai, China	–
Daido Steel Materials Technology Shanghai Co., Ltd.	13	Shanghai, China	–
Daido IT Solutions Co., Ltd.	212	Higashi-ku, Nagoya	https://www.daido-its.co.jp/
Daido Bunseki Research, Inc.	207	Minami-ku, Nagoya	https://www.daido.co.jp/dbr/en/index.html
Daido Life Service Co., Ltd.	412	Minami-ku, Nagoya	https://www.daidolife.co.jp
Kisokoma Heights Co., Ltd.	36	Kiso-machi, Kiso-gun, Nagano	http://www.kisokoma.co.jp
Silent partnership with TAKAKURA FUNDING CORPORATION LTD. as business operator	–	Chiyoda-ku, Tokyo	–

23 other companies

Unmarked: Consolidated subsidiary * Associated company accounted for by the equity method



DAIDO STEEL

DAIDO STEEL GROUP
Beyond the Special

Head Office

Urbannet Nagoya Building, 1-10, Higashisakura 1-chome, Higashi-ku, Nagoya,
Aichi, 461-8581, Japan

TEL: 81-52-963-7501 FAX: 81-52-963-4386

Tokyo Head Office

Daido Shinagawa Building, 6-35, Konan 1-chome, Minato-ku, Tokyo, 108-8478, Japan

TEL: 81-3-5495-1253 FAX: 81-3-5495-6733

Please let us hear your opinions about the Integrated Report 2023.
We will refer to your opinions and comments for future reference.

For inquiries:

ESG Management Department

TEL: 81-52-963-7512 FAX: 81-52-963-4386

<https://www.daido.co.jp/en/ask/about.html?type=profile>

Please refrain from unauthorized reproduction or use of the contents of this material.